

**PLEASANT VALLEY RECREATION & PARK DISTRICT  
COMMUNITY CENTER, SENIOR CENTER  
1605 E. BURNLEY ST., CAMARILLO, CALIFORNIA**

**BOARD OF DIRECTORS  
REGULAR MEETING AGENDA  
March 5, 2025**

**6:00 P.M.**

**REGULAR MEETING**

**NEXT RESOLUTION #780**

- 1. CALL TO ORDER**
- 2. PLEDGE OF ALLEGIANCE**
- 3. ROLL CALL**
- 4. AMENDMENTS TO THE AGENDA** - This is the time and place to change the order of the agenda, delete any agenda item(s), or add any emergency agenda item(s).
- 5. PUBLIC COMMENT** - **In accordance with Government Code Section 54954.3, the Board reserves this time to hear from the public.** If you would like to make comments about a matter within the Board’s subject matter jurisdiction but not specifically on this agenda, in accordance with California law, the Board will listen, note the comments, and may bring the comments back up at a later date as an agenda item for discussion. Speakers will be allowed three minutes to address the Board.
- 6. CONSENT AGENDA** – Matters listed under the Consent Agenda are considered routine and shall be acted upon without discussion and by one motion. If discussion is desired, the item will be removed from the Consent Agenda for discussion and voted on as a separate item. If no discussion is desired, then the suggested action is for the Chair to request that a motion be made to approve the Consent Agenda.
  - A. Minutes for Special Board Meeting of January 25, 2025, and Regular Board Meeting of February 5, 2025**  
Approval receives and files minutes.
  - B. Warrants, Accounts Payable & Payroll**  
District's disbursements dated on or before January 31, 2025.
  - C. Financial Reports**  
Monthly unaudited financial reports are presented to the Board for information. Approval receives and files the financial reports for January 2025.
  - D. Consideration and Approval of Request for Proposal (RFP) for Tree Trimming and Tree Maintenance**  
Staff is seeking proposals for professional tree trimming and tree maintenance services for all 28 parks.
  - E. Consideration and Approval of Establishing the General Manager, Administrative Services Manager, and Park Services Manager Positions as Authorized Signers for CAL OES for a Period of 3 Years**  
The District needs to establish a valid Designation of Applicant’s Agent Resolution for Non-State Agencies (Form 130) with the California Governor’s Office of Emergency Services.

**7. NEW ITEMS – DISCUSSION/ACTION**

**A. Consideration and Receipt of the FY 2023-2024 Annual Financial Report as Prepared by Moss, Levy & Hartzheim LLP, CPAs**

The final annual audit report ensuring the District is following Generally Accepted Accounting Principles (GAAP) is ready for approval.

Suggested Action(s): A MOTION to receive and file the Annual Financial Report for Fiscal Year 2023-2024 as prepared by Moss, Levy & Hartzheim, LLP, CPA's

**B. Consideration and Approval of Bid Award for Type 1 Slurry Seal / Sealcoat and Striping at Various Park Parking Lots**

A Request for Proposal was issued for professional services for Type 1 slurry sealing of the parking lots at three District parks: Mel Vincent, Pitts Ranch and Pleasant Valley Fields.

Suggested Action: A MOTION to Approve bid award and contract for Type 1 slurry seal and striping at Mel Vincent Park, Pitts Ranch Park, and Pleasant Valley Fields to Pavement Coats Co. for an amount not to exceed \$188,550.66 and authorize the General Manager to execute all necessary agreements and documents related to the project.

**C. Consideration and Approval of Bid Award for Springville Park Wrought Iron Fence Repair and Approve a Closure of Springville Dog Park for Turf Maintenance**

Staff seeks to award the bid for wrought iron fence repair at Springville Park to GNR Fencing, transfer funding to cover the project cost and obtain approval for a four-week closure of the park to conduct turf maintenance while the repair work is completed.

Suggested Actions: A MOTION to:

1. Authorize the General Manager to enter into an agreement with GNR Fencing for an amount not to exceed \$85,500 for the wrought iron fence repair at Springville Park.
2. Authorize the closure of Springville Dog Park from March 24<sup>th</sup> to April 28<sup>th</sup> for fencing repairs and turf maintenance.

**8. ORAL COMMUNICATION – INFORMATIONAL ITEMS, which do not require action but relate to District Business, will be reported by members of the Board and staff as follows:**

- A. Chair Dransfeldt**
- B. Ventura County/California Special District Association**
- C. Santa Monica Mountains Conservancy**
- D. Standing Committees: Long Range Planning / Policy / Finance**
- E. Foundation for Pleasant Valley Recreation and Parks**
- F. General Manager's Report**
- G. Board Members**

**9. ADJOURNMENT**

**Notes:** The Board of Directors reserves the right to modify the order in which agenda items are heard. Written materials related to these agenda items are available for public inspection in the Office of the Clerk of the Board, located at 1605 E. Burnley Street, Camarillo, during regular business hours beginning the Friday preceding the Wednesday Board meeting.

**Announcement:** Public Comment: Members of the public may address the Board on any agenda item before or during consideration of the item. [Government Code section 54954.3] Should you need special assistance (*i.e.*, a disability-related modification or accommodations) to participate in the Board meeting or other District activities (including receipt of an agenda in an appropriate alternative format), as outlined in the Americans with Disabilities Act, or require further information, please contact the General Manager at 482-1996, extension 114. Please notify the General Manager 48 hours in advance to provide sufficient time to make a disability-related modification or reasonable accommodation.

**Pleasant Valley Recreation and Park District  
Community Center, Senior Center Building  
Minutes of Special Meeting  
January 25, 2025**

**9:00 A.M.**

**1. CALL TO ORDER**

**2. PLEDGE OF ALLEGIANCE**

**3. ROLL CALL**

All present.

**4. ADOPTION OF AGENDA**

Chair Dransfeldt called for a motion. A motion was made by Director Magner and seconded by Director Schlangen to approve the agenda as presented.

Voting was as follows:

Ayes: Magner, Schlangen, Kelley, Fernandez, Chair Dransfeldt

Noes:

Absent:

**Motion to  
Approve  
Agenda**

Motion: Carried

**Carried**

**5. OPEN COMMUNICATIONS/PUBLIC FORUM – None.**

**6. NEW ITEMS – DISCUSSION/ACTION**

A. Annual Board Goal Setting Workshop

General Manager Mary Otten presented an overview of the 2021-2026 Strategic Plan. Administrative Services Manager Justin Kiraly, Park Services Manager Matt Parker and Recreation Services Manager Nicole Lousen provided highlights of Years 1 – 4 and the goals for Year 5 were presented. Discussion included: grant funding for the SiteLogiq energy program; the need for a special board meeting to reevaluate the Multi-Generational Center; next steps for a possible comprehensive park plan; working with partners for the bike trail; geofencing software; grant opportunities for scholarship assistance; and the need to keep up with board government training with CSDA.

**7. ORAL COMMUNICATIONS – None.**

**8. ADJOURNMENT**

Chair Dransfeldt adjourned the meeting at 12:32 p.m.

**Respectfully submitted,**

**Karen Roberts  
Recording Secretary**

**Approval,**

**Bev Dransfeldt  
Chair**

**Pleasant Valley Recreation and Park District  
Community Center, Senior Center Building  
Minutes of Regular Meeting  
February 5, 2025**

**6:00 P.M.**

**REGULAR MEETING**

**1. CALL TO ORDER**

**2. PLEDGE OF ALLEGIANCE**

**3. ROLL CALL**

All present.

**4. AMENDMENTS TO THE AGENDA**

Chair Dransfeldt called for a motion. A motion was made by Director Magner and seconded by Director Kelley to accept the agenda as presented.

**Motion to  
Approve  
Agenda**

Voting was as follows:

Ayes: Magner, Kelley, Fernandez, Schlangen, Chair Dransfeldt

Noes:

Absent:

**Carried**

Motion: Carried

**5. PRESENTATIONS**

**A. District Highlights**

Recreation Specialist Samantha Silveira presented highlights of the District's programs, activities and special events for November and December and showed a short Christmas Parade video.

**6. PUBLIC COMMENT**

No comments.

**7. CONSENT AGENDA**

**A. Minutes for Regular Board Meeting of January 9, 2025**

**B. Warrants, Accounts Payable & Payroll**

**C. Financial Reports**

**D. Consideration and Adoption of Resolution No. 779 Directing SCI Consulting Group to Prepare the FY 2025-2026 Engineer's Report for the Assessment District**

**E. Consideration and Approval for the General Manager to Issue a Request for Bids (RFB) for a Community Center Fire Alarm System**

**F. Review and Approval of Surplus Supplies and Equipment List**



Chair Dransfeldt called for a motion. A motion was made by Director Magner and seconded by Director Schlangen to approve the Consent Agenda.

**Motion to Approve Consent Agenda**

Voting was as follows:

Ayes: Magner, Schlangen, Kelley, Fernandez, Chair Dransfeldt

Noes:

Absent:

**Carried**

Motion: Carried

**8. NEW ITEMS – DISCUSSION/ACTION**

A. Consideration and Approval for Award of Contract for Freedom Park Restroom/Concession Stand Remodel Design

Park Services Manager Matt Parker presented BOA Architecture’s proposal for architectural/design services at Freedom Park. Discussion included: consideration of retrofitting versus a prefabricated building; inclusion for site surveys and electrical & plumbing set up designs; and consideration of appropriate layout for the concession stand.

**Motion to Approve Award of Contract to BOA for Freedom Restroom & Concession Stand**

Chair Dransfeldt called for a motion. A motion was made by Director Magner and seconded by Director Schlangen to approve an award of the contract for the Freedom Park restroom remodel design to BOA Architecture for \$68,200 and to authorize the General Manager to execute the agreement and take all necessary actions to proceed with the project.

Voting was as follows:

Ayes: Magner, Schlangen, Kelley, Fernandez, Chair Dransfeldt

Noes:

Absent:

**Carried**

Motion: Carried

B. Consideration and Approval of \$25,000 for Placer.ai 12 Month Agreement Funding

Administrative Services Manager Justin Kiraly presented consideration of an extended purchase of geofencing software, Placer.ai. Staff have been utilizing the data for the last 4 months and are looking to purchase the service for another 12 months. Discussion included: availability of excess funds in Professional & Special Services; need for consideration if adding on more land; question on usefulness of continuing to pay for access to data that we currently have; and benefit of having the data so that the District can go to various partners for possible sponsorships.

**Motion to Approve Placer.ai Services**

Chair Dransfeldt called for a motion. A motion was made by Director Magner and seconded by Director Kelley to approve the use of \$25,000 of Professional & Special Services (7100) funds to purchase one year of Placer.ai services.

Voting was as follows:

Ayes: Magner, Kelley, Fernandez, Chair Dransfeldt

Noes: Schlangen

Absent:

Motion: Carried

Carried

**9. ORAL COMMUNICATIONS – INFORMATIONAL ITEMS**

A. Chair Dransfeldt – Chair Dransfeldt reported that she attended a community meeting with Assemblymember Steve Bennett which discussed structure hardening along with info from the Ventura Regional Firesafe Council for house assessments. Ms. Dransfeldt stated that Director Magner was awarded Director of the Year at the VCSDA meeting at Conejo last night.

B. Ventura County Special District Association/California Special District Association – VCSDA – Director Magner stated that she was surprised to receive the award. She reported that the chapter needs to have all of its special district members become involved in the meetings again. CSDA - Director Magner attended a legislative meeting in January and is on the Government Human Resources and Revenue working group.

C. Santa Monica Mountains Conservancy – Chair Dransfeldt reported the January 27 meeting provided an overview of the properties affected by the recent wildfires and the preventative measures SMMC has incorporated over the years. Mentioned also were the losses in the Will Rogers State Park and the historic Topanga Ranch Hotel. The next meeting will be February 24.

D. Standing Committees –Personnel – Director Fernandez stated the committee reviewed the personnel handbook. Finance – Chair Dransfeldt stated the committee meets the 3<sup>rd</sup> Wednesday of the month.

E. Foundation for Pleasant Valley Recreation and Parks – Chair Dransfeldt stated the next meeting will be held on February 12 and there is a fundraiser at Urbane Café also.

F. General Manager’s Report – General Manager Mary Otten reported on current projects and studies that staff are working on along with programs and special events. The District board meetings might be held again in City Hall starting in April.

G. Board Members – The Directors updated on the meetings and District events they attended for the month. Foundation is hosting a cornhole event at the District’s Spring into Summer Showcase on March 22. CSDA is offering webinars regarding governance with 4 modules for 3 hours each. Director Magner is recommending the board members complete governance trainings in order for the District to receive its transparency certificate and for the District of Distinction program. Director Kelley suggested that representatives from the LA City Fire Department come to Camarillo to conduct a presentation on the wildfires and provide tips on how to save our homes from fires.

**10. ADJOURNMENT**

Chair Dransfeldt adjourned the meeting at 7:39 p.m.

**Respectfully submitted,**

**Approval,**

**Karen Roberts**  
**Recording Secretary**

**Bev Dransfeldt**  
**Chair**

Pleasant Valley Recreation and Park District  
 Monthly AP, Payroll, Wire, Online Payment Report  
 January 2025

	Date	Amount	
Accounts Payables:	1/31/2025	\$ 468,493.09	
	<b>Total</b>	<b>\$ 468,493.09</b>	
Payroll (Total Cost):	1/2/2025	\$ 172,988.92	
	1/16/2025	\$ 173,575.02	
	1/30/2025	\$ 158,357.94	
	<b>Total</b>	<b>\$ 504,921.88</b>	
Payroll AP Payments	1/2/2025	\$ 47,280.62	PERS Health Insurance Premium
	1/2/2025	\$ 3,926.22	Guardian
	1/2/2025	\$ 583.80	VSP
	1/2/2025	\$ 2,265.72	Hartford
	1/2/2025	\$ 20,139.42	CALPERS - Ret-PR 1/2/2025
	1/16/2025	\$ 20,009.51	CALPERS- Ret-PR-1/16/2025
	1/30/2025	\$ 20,029.19	CALPERS- Ret-PR-1/30/2025
	<b>Total</b>	<b>\$ 114,234.48</b>	
	<b>Grand Total</b>	<b>\$ 1,087,649.45</b>	

## CASH REPORT

	1/31/2025 Balance	1/31/2024 Balance
<b>Restricted Funds</b>		
Debt Service - Restricted	\$ 157,170.59	\$ 149,550.13
457 Pension Trust Restricted	\$ 163,132.54	\$ 72,712.05
Cal CLASS/PW Quimby Fee - Restricted	\$ 4,259,623.65	\$ 4,424,881.16
VC Pool Quimby- Restricted	\$ 2,756,709.07	\$ 2,642,575.66
Park Impact Fees	\$ 2,136,993.28	\$ 2,047,477.29
FCDP Checking	\$ -	\$ -
<b>Total</b>	<b>\$ 9,473,629.13</b>	<b>\$ 9,337,196.29</b>
<b>Semi-Restricted Funds</b>		
Assessment	\$ 1,213,693.04	\$ 1,109,211.82
LAIF - Capital	\$ 1,587,644.19	\$ 1,454,708.41
PacWest/CalCLASS - Capital	\$ 2,048,390.87	\$ 1,946,454.62
Designated Project	\$ 230,484.00	\$ 230,484.00
Capital Reserves	\$ 500,000.00	\$ 500,000.00
Capital - Vehicle Replacement	\$ -	\$ 49,843.80
Contingency - Dry Period	\$ 467,337.09	\$ 467,337.09
Contingency - Computer	\$ 33,000.00	\$ 33,000.00
Contingency - Repair/Oper/Admin	\$ 420,000.00	\$ 420,000.00
Contingency - Compensated Absences	\$ 125,000.00	\$ 125,000.00
Contingency - Vehicle Replacement	\$ 80,000.00	\$ 45,000.00
<b>Total</b>	<b>\$ 6,705,549.19</b>	<b>\$ 6,381,039.74</b>
<b>Unrestricted Funds</b>		
Contingency	\$ 7,021,181.92	\$ 5,891,805.30
General Fund Checking	\$ 723,689.69	\$ 654,853.27
<b>Total</b>	<b>\$ 7,744,871.61</b>	<b>\$ 6,546,658.57</b>
<b>Total of all Funds</b>	<b>\$ 23,924,049.93</b>	<b>\$ 22,264,894.60</b>

	2/14/2025 Balance	2/28/2024 Balance
<b>Restricted Funds</b>		
Debt Service - Restricted	\$ 157,170.59	\$ 150,170.67
457 Pension Trust Restricted	\$ 163,132.54	\$ 73,010.78
Cal CLASS/PW Quimby Fee - Restricted	\$ 4,259,623.65	\$ 4,441,488.88
VC Pool Quimby- Restricted	\$ 2,756,709.07	\$ 2,655,096.08
Park Impact Fees	\$ 2,136,993.28	\$ 2,056,276.31
FCDP Checking	\$ -	\$ -
<b>Total</b>	<b>\$ 9,473,629.13</b>	<b>\$ 9,376,042.72</b>
<b>Semi-Restricted Funds</b>		
Assessment	\$ 1,142,742.86	\$ 1,058,952.83
LAIF - Capital	\$ 1,587,644.19	\$ 1,454,708.41
PacWest/CalCLASS - Capital	\$ 2,048,390.87	\$ 1,954,755.39
Designated Project	\$ 230,484.00	\$ 230,484.00
Capital Reserves	\$ 500,000.00	\$ 500,000.00
Capital - Vehicle Replacement	\$ -	\$ 49,843.80
Contingency - Dry Period	\$ 467,337.09	\$ 467,337.09
Contingency - Computer	\$ 33,000.00	\$ 33,000.00
Contingency - Repair/Oper/Admin	\$ 420,000.00	\$ 420,000.00
Contingency - Compensated Absences	\$ 125,000.00	\$ 125,000.00
Contingency - Vehicle Replacement	\$ 80,000.00	\$ 45,000.00
<b>Total</b>	<b>\$ 6,634,599.01</b>	<b>\$ 6,339,081.52</b>
<b>Unrestricted Funds</b>		
Contingency	\$ 7,021,181.92	\$ 5,918,553.29
General Fund Checking	\$ 476,014.12	\$ 296,912.17
<b>Total</b>	<b>\$ 7,497,196.04</b>	<b>\$ 6,215,465.46</b>
<b>Total of all Funds</b>	<b>\$ 23,605,424.18</b>	<b>\$ 21,930,589.70</b>

# Bank Reconciliation

## Board Audit

User: Cwebster  
 Printed: 02/06/2025 - 10:23AM  
 Date Range: 01/01/2025 - 01/31/2025  
 Systems: 'AP'



Check No.	Vendor/Employee	Transaction Description	Date	Amount
Fund: 10 General Fund				
Department: 00 Non Departmentalized				
0	AFLAC	AFLAC: BILLING ACTIVITY DEC 2	01/02/2025	992.16
0	CALPERS HEALTH	CALPERS: HEALTH INS JAN 2025	01/02/2025	47,280.62
0	CALPERS PENSION	CALPERS: PR CONT 1/2/2025 / PLA	01/02/2025	20,139.42
0	CALPERS PENSION	PERS CONT PR 1/16/2025/ PLAN 96	01/16/2025	20,009.51
0	CALPERS PENSION	PERS CONTRIBUTION PR 1/30/202	01/30/2025	20,029.19
0	EMPLOYMENT DEVELOPMENT DI	EDD: DE88 PMT / PR 1/2/2025	01/02/2025	4,435.88
0	EMPLOYMENT DEVELOPMENT DI	DE88 PMT/ PR 1/16/2025	01/16/2025	4,253.26
0	EMPLOYMENT DEVELOPMENT DI	DE 88 PMT / PR 1/30/2025	01/30/2025	3,926.22
0	GUARDIAN	GUARDIAN: DENTAL BILLING JA	01/02/2025	3,644.59
0	HARTFORD LIFE & ACC. INSURAN	HARTFORD: LIFE INS BILLING JA	01/02/2025	2,265.72
0	HUB INTERNATIONAL INSURANC	HUB: INSURANCE NOV 2024	01/09/2025	2,083.00
0	INTERNAL REVENUE SERVICE - O	IRS: EFTPS 941 PMT / PR 1/2/2025	01/02/2025	28,323.42
0	INTERNAL REVENUE SERVICE - O	EFTPS 941 PMT / PR 1/16/2025	01/16/2025	28,422.94
0	INTERNAL REVENUE SERVICE - O	EFTPS 941 PMT / PR 1/30/2025	01/30/2025	30,567.47
0	VSP	VSP: VISION INS JAN 2025 BILLIN	01/02/2025	583.80
27603	METLIFE INSURANCE CO USA	METLIFE: JUAREZ, JAVIER/SSN 4	01/02/2025	100.00
27621	JOURNEY COMMUNITY CHURCH	JOURNEY THE CHURCH: CLEANI	01/09/2025	850.00
27632	TAYLENE YNIQUEZ	YNIQUEZ, T: CLEANING DEP REF	01/09/2025	50.00
27634	METLIFE INSURANCE CO USA	JUAREZ, JAVIER/ SSN 4326/ PAY P	01/16/2025	100.00
27638	CAMARILLO NEWCOMER'S CLUB	CLEANING DEP REFUND/ CONTR	01/23/2025	50.00
27639	CAMARILLO QUILTERS ASSOC.	CLEANING DEP REFUND/ CONTR	01/23/2025	100.00
27662	VENTURA GUIDE DOGS OF AMER	CLEANING DEP REFUND/ CONTR	01/23/2025	50.00
27665	METLIFE INSURANCE CO USA	JUAREZ, JAVIER/ SSN 4326 / PAY P	01/30/2025	100.00
Total for Department: 00 Non Departmentalized				218,357.20
Department: 03 Recreation				
0	AMAZON	AMAZON: STAMPS	01/09/2025	1,289.15
0	BEGINNERS EDGE SPORTS TRAIN	SPORTS CLASSES / NOV - DEC 20	01/23/2025	1,134.11
0	DEBRA GREENWOOD	WATER EXERCISE CLASS /2024-12	01/23/2025	1,008.80
0	ESTELA LIZARRAGA	LIZARRAGA, E: DEC 2024 CLASSE	01/09/2025	976.30
0	RUTH ATWATER	ATWATER, R: SEPT- DEC 2024 TAI	01/09/2025	4,192.50
0	SOCAL GAS COMPANY	SVC DATE 2024-11/25 - 12/26 / AQU	01/08/2025	3,999.51
0	US BANK	CAL CARD STMT 12/23/2024	01/08/2025	5,899.03
27609	AMR AMBULANCE SERVICE INC	AMR AMBULANCE SVC: STANDB	01/09/2025	768.00
27612	BINGO WEST #4	BINGO WEST: BINGO SUPPLIES	01/09/2025	750.75
27617	DIAL SECURITY	DIAL SECURITY: 12/13 SVC CHRIS	01/09/2025	319.00
27618	DURHAM SCHOOL SERVICES	DURHAM SCHOOL SVC: BAND BU	01/09/2025	4,000.00
27623	KIEFER AQUATICS	KIEFER AQUATICS: LANE LINE/ A	01/09/2025	1,610.79
27624	MARK-IT PLACE	MARK IT PLACE: TROPHIES/CHRI	01/09/2025	326.95
27626	PLAY-WELL TEKNOLOGIES	PLAYWELL TEK: WINTER WONDI	01/09/2025	292.50
27627	STANDARD SITE RENTALS INC	STANDARD SITE RENTALS: RR/SI	01/09/2025	3,124.65
27629	TOTAL BARRICADE SERVICE, INC	TOTAL BARRICADE SVC: DELINE	01/09/2025	220.00
27641	CASEY PRINTING	WINTER/SPRING 2025 ACTIVITY C	01/23/2025	10,197.00
27649	ROBERT INGLIS	SCUBA CLASSES / 8 ENROLLED	01/23/2025	509.60
27652	BRYAN MONKA	SOCCER CLASSES / DEC 2024	01/23/2025	294.45
27657	BRIAN SMALLWOOD	SWIM CLASSES / JUN - DEC 2024	01/23/2025	666.25
27660	ULINE	PAPER GROCERY BAGS	01/23/2025	3,512.53
27663	WHENTOWORK, LLC	ONLINE SCHEDULING/ 1 YR SUB:	01/23/2025	1,320.00

Check No.	Vendor/Employee	Transaction Description	Date	Amount
27664	DUNCAN YOUNG	GYMNASTICS CLASS JAN 2025 /40	01/23/2025	1,781.00
Total for Department: 03 Recreation				48,192.87
Department: 04 Parks				
0	ADAM WHEAT	WHEAT, A: BOOTS REIMB FY 25	01/09/2025	250.00
0	ALBERTO SILVA	SILVA, A: BOOTS REIMB FY 2025	01/09/2025	435.44
0	ARAMSCO INC.	FLOOR MATS / SENIOR CENTER	01/23/2025	228.12
0	ARMANDO MADERA	MADERA, A: BOOTS REIMB FY 20	01/09/2025	250.00
0	CLAYTON RUTKOWSKI	PANTS ALLOWANCE FY 2025	01/23/2025	200.00
0	CULLIGAN OF VENTURA COUNTY	CULLIGAN: TICKET# 3352456	01/09/2025	12.45
0	DUSTIN FABER	FABER, D: BOOTS REIMB FY 202	01/09/2025	250.00
0	E.J. HARRISON AND SONS, INC.	E.J. HARRISON: DEC 2024 BILLING	01/09/2025	5,739.56
0	GRAINGER	GRAINGER: AIRHOSE	01/09/2025	107.15
0	GRAINGER	SPINDLE PARTS / AQUATIC CENT.	01/23/2025	97.65
0	HUB INTERNATIONAL INSURANC	HUB: INSURANCE OCT 2024	01/09/2025	-104.28
0	JESSE GOMEZ	GOMEZ, J: PANTS REIMB FY 2025	01/09/2025	200.00
0	LINCOLN AQUATICS	POOL ACID / AQUATIC CENTER	01/23/2025	1,159.64
0	SAM RIOS	RIOS, S: PANTS REIMB FY 25	01/09/2025	200.00
0	SITEONE LANDSCAPE SUPPLY LL	SITEONE: IRRIGATION / MEL VINC	01/09/2025	338.48
0	SITEONE LANDSCAPE SUPPLY LL	NEW VFD YASKAWA	01/23/2025	40,228.48
0	SOCAL GAS COMPANY	SVC DATE 2024-11/30 - 12/31 / PAR	01/08/2025	1,025.40
0	SOUTHERN CALIF EDISON COMP/	SVC DATE 2024-11/23 - 12/23/ NAN	01/09/2025	3,642.81
0	SOUTHERN CALIF EDISON COMP/	SVC DATE 2024-12/20 - 2025-1/21 /	01/23/2025	8,983.01
0	TMOBILE/SPRINT	BILLING DATE DEC 2024	01/23/2025	268.50
0	UNITED SITE SERVICES OF CA INC	UNITED SITE: SVC DATE 2024-12/	01/09/2025	188.17
0	UNITED SITE SERVICES OF CA INC	SVC DLX RR/ 2025-1/14 2/10 / SPRI	01/23/2025	188.17
0	US BANK	CAL CARD STMT 12/23/2024	01/08/2025	4,161.19
0	WATER & SANITATION SERVICES	WATER & SANITATION: SVC DATI	01/09/2025	641.92
0	WEX BANK	WEX BANK: FUEL REBATE DEC 2	01/09/2025	4,308.74
27604	CITY OF CAMARILLO	CITY OF CAM: SVC DATE 2024-10/	01/02/2025	25,529.98
27607	ALL PHASE ELECTRIC	ALL PHASE: LIGHT POLES / PITTS	01/09/2025	2,782.46
27610	B & B DO IT CENTER	B&B: SANDING DISC/ DOS CAMIN	01/09/2025	862.09
27611	BIGBRAND TIRE & SERVICE	BIG BRAND: TIRES TRUCK# 37	01/09/2025	445.95
27613	CITY OF OXNARD - TREASURER	CITY OF OXNARD: NOV 2024 REC	01/09/2025	1,207.21
27614	COASTAL PIPCO IRRIGATION INC.	COASTAL PIPCO: SPRAYER FOR C	01/09/2025	230.87
27615	COUNTY OF VENTURA	COUNTY OF VENTURA: BUSINES	01/09/2025	2,187.96
27616	CRESTVIEW MUTUAL WATER CO.	CRESTVIEW: DEC 2024 BILLING/1	01/09/2025	116.06
27620	DANIEL GARCIA	GARCIA, D: SEABREEZE WINDOW	01/09/2025	2,919.53
27622	KASTLE KARE	KASTLE KARE: GOPHER DEC MO	01/09/2025	1,200.00
27628	THE ADJUL CORPORATION	THE ADJUL CORP: LEE CONSTRU	01/09/2025	8,321.67
27630	TRAFFIC TECHNOLOGIES LLC.	TRAFFIC TECH: SKATE PARK RUI	01/09/2025	830.85
27633	CITY OF CAMARILLO	SVC DATE 2024-11/20 - 12/20 / MEL	01/09/2025	27,283.44
27635	AMERICAN RESOURCE RECVY	DEC 2024 BILLING / PV FIELDS	01/23/2025	947.39
27636	B & B DO IT CENTER	TILE REPAIR / COMM CENTER	01/23/2025	548.55
27637	BAY ALARM	ALARM SVC 2025-2/1 - 4/30/ COMM	01/23/2025	150.00
27640	CAMROSA WATER DISTRICT	SVC DATE DEC 2024/ BIRCHVIEW	01/23/2025	12,400.18
27642	COASTAL PIPCO IRRIGATION INC.	IRRIGATION / CHARTER OAK PAR	01/23/2025	1,163.27
27643	COUNTY OF VENTURA	SNACK BAR FEE / PV FIELDS	01/23/2025	728.00
27644	COUNTY OF VENTURA- IT	RADIO COMM ISF / SVC CONTRA	01/23/2025	183.12
27645	DIAL SECURITY	SECURITY SVC EVENT 11/30/2024	01/23/2025	522.00
27646	ENVISION FORD LINCOLN OF OX	AB3Z-19E616-B /TRUCK# 35	01/23/2025	67.54
27648	FJS LAND CONSULTING INC	LAND SURVEY / PV FIELDS	01/23/2025	2,250.00
27650	KELLY'S AFFORDABLE PORTABLE	PORTABLE RR / PV FIELDS	01/23/2025	2,207.70
27653	NAPA AUTO PARTS	OIL FILTERS	01/23/2025	279.21
27654	PEACH HILL SOILS INC.	MULCH / VALLE LINDO PARK	01/23/2025	3,024.45
27655	R & R PRODUCTS, INC.	SAND PRO / SHOP	01/23/2025	640.55
27658	THE FINISH LINE	SHIRTS/SWEATSHIRTS / FALL 202	01/23/2025	3,073.05
27659	TRANSMISSION PARTS OF OXNAR	TRANSMISSION TRUCK# 13	01/23/2025	5,107.01
27661	U-RENT INC.	TRUCK DUMP / SAND REMOVAL /	01/23/2025	507.29
27662	VENTURA GUIDE DOGS OF AMER	REFUND CONTRACT# 4740	01/23/2025	76.00
27666	CITY OF CAMARILLO	SVC DATE 2024-11/25- 12/26 / CAR	01/29/2025	11,039.78

Check No.	Vendor/Employee	Transaction Description	Date	Amount
			Total for Department: 04 Parks	191,833.76
Department: 05 Administration				
0	ALESHIRE & WYNDER LLP	LEGAL SVC DEC 2024/ GENERAL	01/23/2025	6,185.87
0	AMAZON	AMAZON: BARCODE SCANNER/ /	01/09/2025	77.61
0	AMILIA TECHNOLOGIES USA, INC	AMILIA: SUBSCRIPTION FEE DEC	01/09/2025	5,088.91
0	CALPERS HEALTH	CALPERS: HEALTH INS JAN 2025	01/02/2025	1,677.63
0	CULLIGAN OF VENTURA COUNTY	CULLIGAN: POU COOLER/ JAN 20	01/09/2025	36.77
0	GUARDIAN	GUARDIAN: DENTAL BILLING JA	01/02/2025	51.49
0	HUB INTERNATIONAL INSURANC	HUB: JAN 2024 PMT RECEIPT	01/09/2025	3.00
0	KONICA MINOLTA PREMIER FINA	BILLING DATE JAN 2025	01/23/2025	573.19
0	QUADIENT LEASING USA, INC.	QUADIENT LEASING: BILL DATE	01/09/2025	300.41
0	SPECTRUM BUSINESS	SPECTRUM: SVC DATE 2024-12/17	01/09/2025	17.10
0	STAPLES BUSINESS ADVANTAGE	STAPLES: SUPPLIES	01/09/2025	762.13
0	STREAMLINE	STREAMLINE: BILLING PERIOD J	01/09/2025	3,806.03
0	TMOBILE/SPRINT	BILLING DATE DEC 2024	01/23/2025	47.80
0	US BANK	CAL CARD STMT 12/23/2024	01/08/2025	827.45
0	VSP	VSP: VISION INS JAN 2025 BILLIN	01/02/2025	20.85
0	WATER & SANITATION SERVICES	WATER & SANITATION: PROCESS	01/09/2025	0.75
27605	ADVANTAGE TELECOM	ADVANTAGE: INTERNET SVC JAN	01/09/2025	1,591.09
27608	ALLCONNECTED, INC.	ALLCONNECTED: JAN 2024 BILLI	01/09/2025	4,462.46
27631	VCSDA	VCSDA: DINNER MEETING DUES	01/09/2025	105.00
27660	ULINE	CHAIRS / SENIOR CENTER	01/23/2025	198.48
			Total for Department: 05 Administration	25,834.02
			Total for Fund:10 General Fund	484,217.85

Check No.	Vendor/Employee	Transaction Description	Date	Amount
Fund: 20 Assessment Fund				
Department: 00 Non Departmentalized				
27606	AGROMIN HORTICULTURAL PROI	AGROMIN: TOPPER/PV FIELDS/ D	01/09/2025	36,293.70
27619	EXECUTIVE FACILITIES SERVICES	EXECUTIVE FACILITES: NOV 2024	01/09/2025	8,452.92
27625	NATURAL GREEN LANDSCAPES, I	NATURAL GREEN LANDSCAPE: E	01/09/2025	16,659.27
27647	EXECUTIVE FACILITIES SERVICES	JANITORIAL SVC DEC 2024/ PV FI	01/23/2025	6,549.12
27656	SHOWSCAPES, INC	LANDSCAPE MAIN DEC 2024 / PV	01/23/2025	21,772.66
Total for Department: 00 Non Departmentalized				89,727.67
Total for Fund:20 Assessment Fund				89,727.67



Check No.	Vendor/Employee	Transaction Description	Date	Amount
Fund: 30 Park Dedication Fund				
Department: 00				
0	US BANK	CAL CARD STMT 12/23/2024	01/08/2025	89.07
27651	LAUTERBACH & ASSOCIATES, INC	DEC 2024 BILLING/ PICKLEBALL	01/23/2025	8,447.50
27666	CITY OF CAMARILLO	SVC DATE 2024-11/30- 12/31 / HYR.	01/29/2025	245.48
Total for Department: 00				8,782.05
Total for Fund:30 Park Dedication Fund				8,782.05

Check No.	Vendor/Employee	Transaction Description	Date	Amount
		Grand Total		582,727.57

Developer	Project			Quimby Funds		GL Code				
	No.	Location	Description	Budgeted	Expended		Awarded	Balance	Committed Date	Allocation Date
<b>FAIRFIELD LLC</b>										
Public Hearing 11/7/2018	1	Freedom	Freedom Baseball Fields- Non- Contract Cost		\$ 504,121.78	\$ 2,250,489.70	\$ 2,250,489.70	11/7/2018	1/31/2020	8459
	2	Freedom	Freedom Baseball Fields- Contract Cost	\$ 1,100,000.00	\$ 411,628.87		\$ 1,746,367.92			
Public Hearing 7/3/19	3	PV AC	PVAC Restrooms and Showers	\$ 500,000.00	\$ 647,336.74		\$ 1,334,739.05			8469
Mid-Year Budget Adj. 2/5/2020	4	PV Fields	Fertilizer Injector System	\$ 60,000.00	\$ 50,788.90		\$ 636,613.41			8478
	5		Senior and Community Rec Fac Project		\$ 328,146.58		\$ 308,466.83			8511
	6		Senior and Community Rec Fac Exterior Proj		-		\$ 308,466.83			
	7		Community Center Kitchen Expansion	\$ 250,000.00	\$ 280,649.20		\$ 27,817.63			8480
	8		Community Center Classroom and Auditorium Enhancements							
	9		Freedom Park Parking Lot Enhancement				\$ 340,775.98			
	10		Freedom Park Landscape and Walking Path							
	11		Camarillo Grove Nature Center							
				\$ 1,910,000.00	\$ 2,222,672.07		\$ 27,817.63			
<b>ELACORA MISSION OAKS</b>										
Budget Allocation 11/5/2020	1	Encanto	PG Equipment Installation		\$ 189,887.74	\$ 2,649,209.00	\$ 2,649,209.00		8/8/2021	
Budget Allocation 7/7/2021	2	Arnell Reh Pk	Arnell Ranch Park Renovation	\$ 1,500,000.00	\$ 1,496,641.96		\$ 2,459,321.26	11/3/2016		8464
	3		Pickleball	\$ 1,400,000.00	\$ 337,008.41		\$ 962,679.30	11/5/2020		8493
	4		Camarillo Nature Center	\$ 300,000.00	-		\$ 625,670.89			
	5		Freedom Park Landscape and Walking Path		-		\$ 625,670.89			
			Freedom Baseball Fields	\$ 3,200,000.00	\$ 2,023,538.11		\$ 625,670.89			
<b>KB HOMES</b>										
Public Hearing 7/5/2018	1	Valle Lindo	Valle Lindo RR/Pavillion*	\$ 425,000.00	\$ 32,368.30	\$ 474,353.00	\$ 474,353.00		8/10/2021	8444
Public Hearing 7/5/2018	2	Mel Vincent	Mel Vincent Park Restrooms	\$ 139,500.00	\$ 166,253.78		\$ 441,984.70			8460
Public Hearing 7/5/2018	3	Nancy Bush	Nancy Bush Pavillion	\$ 65,000.00	\$ 31,537.74		\$ 275,730.92			8447
	4		Community Center Classroom and Auditorium Enhancements		\$ 949.16		\$ 243,244.02			8513
	5		Des Caminos Expansion and ADA		-		\$ 243,244.02			
				\$ 629,500.00	\$ 231,108.98		\$ 243,244.02			
<b>HABITAT FOR HUMANITY</b>										
Public Hearing 3/6/2024	1		Community Center Improvements	\$ 35,242.00	-	\$ 35,242.00	\$ 35,242.00		9/17/2024	
	2		Freedom Pickleball Courts	\$ 35,242.00	-	\$ 35,242.00	\$ 35,242.00			
				\$ 70,484.00	-	\$ 70,484.00	\$ 70,484.00			
<b>SHEA HOMES</b>										
Public Hearing 7/5/2023	1		Multi-Generation Center	\$ 1,000,000.00	-	\$ 1,264,500.00	\$ 1,264,500.00		11/21/2024	8504
	2		Freedom Park ADA Bathroom	\$ 500,000.00	\$ 48.49		\$ 1,264,500.00	7/5/2023		8529
	3		Freedom Park Improvements		-		\$ 1,264,451.51	11/4/2024		
	4		Community Center Improvements		-		\$ 1,264,451.51	11/4/2024		
				\$ 1,500,000.00	\$ 48.49		\$ 1,264,451.51			
<b>Williams Homes</b>										
				\$ 2,840,447.45		\$ 2,840,447.45	\$ 2,840,447.45		7/29/2027	
<b>Somis Ranch Phase 1</b>										
				\$ 347,625.00		\$ 347,625.00	\$ 347,625.00		8/5/2027	
<b>Somis Ranch Phase 2</b>										
				\$ 278,100.00		\$ 278,100.00	\$ 278,100.00		10/20/2027	
<b>Barry 60 LP</b>										
				\$ 313,508.00		\$ 313,508.00	\$ 313,508.00		3/15/2028	
<b>Interest</b>										
				\$ 1,040,226.22		\$ 1,040,226.22	\$ 1,040,226.22			
<b>Grand Total</b>				\$ 8,052,196.25	\$ 5,114,688.90	\$ 12,131,021.62	\$ 7,016,352.72			

Pleasant Valley Recreation and Park District  
Park Impact Fee's Collected

<b>FY2022</b>				
<b>Date Received</b>	<b>Amount</b>		<b>Applicant</b>	<b>Project</b>
10/28/2021	\$	158.40	Square One Arch	Messner Filtration
12/20/2021	\$	6,983.00	Art Wahl	Stern Residence
12/21/2021	\$	158,222.80	Levon Ghukasyan	Village at the Park
3/23/2022	\$	6,983.00	Crestview Ranch	Spanish Hills Estates
<b>Total Received</b>	<b>\$</b>	<b>172,347.20</b>		
<b>Interest Earned</b>	<b>\$</b>	<b>11.90</b>		
<b>PVRPD Administrative Fee</b>	<b>\$</b>	<b>(3,446.94)</b>		
<b>City Administrative Fee</b>	<b>\$</b>	<b>(3,446.94)</b>		

<b>FY2023</b>				
<b>Date Received</b>	<b>Amount</b>		<b>Applicant</b>	<b>Project</b>
9/29/2022	\$	218.40	Raymond Dickerhoff	Wedgewood Weddings
1/10/2023	\$	7,712.79	Travis Rodriguez	Jenkins Residence
3/6/2023	\$	7,712.79	Michael Dubin	600 Corte Corride
4/25/2023	\$	187.98	Daiva McBride	House of Bamboo
4/28/2023	\$	7,712.79	Phineas Turner	RPD-206
5/4/2023	\$	69.81	Sustainability Engineering Group	Ralph's Fuel Center
5/24/2023	\$	17,511.56	RJ Rieves	Rexford Ind.
5/26/2023	<del>\$</del>	<del>7,945.00</del>	Siamak Rezvani (Refunded)	Crestview
<b>Total Received</b>	<b>\$</b>	<b>41,126.12</b>		
<b>Interest Earned</b>	<b>\$</b>	<b>5,998.78</b>		
<b>PVRPD Administrative Fee</b>	<b>\$</b>	<b>(981.42)</b>		
<b>City Administrative Fee</b>	<b>\$</b>	<b>(981.42)</b>		

<b>FY2024</b>				
<b>Date Received</b>	<b>Amount</b>		<b>Applicant</b>	<b>Project</b>
9/7/2023	\$	1,771,314.00	Grant Williams	RPD-201 Camino Ruiz
11/30/2023	\$	2,060.00	Dillon Merchant	Chick Fil-A
3/5/2024	\$	660.00	Mahdi Rezvan	Arnell Pharmacy
3/18/2024	\$	18,577.89	Robert Goetsch	IPD-405
3/26/2024	\$	21,706.91	Charles Sandlin	Gleson/Dawson Self Storage
<b>YTD Received</b>	<b>\$</b>	<b>1,814,318.80</b>		
<b>YTD Interest Earned</b>	<b>\$</b>	<b>93,232.69</b>		
<b>PVRPD Administrative Fee</b>	<b>\$</b>	<b>(36,286.37)</b>		
<b>City Administrative Fee</b>	<b>\$</b>	<b>(36,286.38)</b>		

<b>FY2025</b>				
<b>Date Received</b>	<b>Amount</b>		<b>Applicant</b>	<b>Project</b>
7/19/2024	\$	8,159.33	Connor Christ	PR-1061
7/19/2024	\$	8,159.33	Travis Rodriguez	PR-1062
7/19/2024	\$	8,159.33	Connor Christ	PR-1063
10/28/2024	\$	80.36	Rick Morga	IPD-258TI
11/25/2024	\$	3,405.87	Texas Roadhouse	CPD-256
<b>YTD Received</b>	<b>\$</b>	<b>27,964.22</b>		
<b>YTD Interest Earned</b>	<b>\$</b>	<b>63,423.04</b>		
<b>Balance as of 12/31/2024</b>	<b>\$</b>	<b>2,136,993.28</b>		

<b>5-Year Findings Report Due</b>	<b>FY2027 (w/in 180D)</b>
	FY2032 (w/in 180D)
	FY2037 (w/in 180D)
	FY2042 (w/in 180D)

### California CLASS

Investment Name	Aug-23	Sep-23	Oct-23	Nov-23	Dec-23	Jan-24	Feb-24	Mar-24	Apr-24
<b>California CLASS</b>	5.45%	5.48%	5.51%	5.55%	5.54%	5.47%	5.44%	5.42%	5.40%
	May-24	Jun-24	Jul-24	Aug-24	Sep-24	Oct-24	Nov-24	Dec-24	Jan-25
<b>California CLASS</b>	5.39%	5.40%	5.42%	5.41%	5.26%	5.00%	4.83%	4.63%	4.42%

- Rates are determined at the end of the month

### Ventura County Pool

Investment Name	Aug-23	Sep-23	Oct-23	Nov-23	Dec-23	Jan-24	Feb-24	Mar-24	Apr-24
<b>Ventura County Pool</b>	3.51%	3.64%	3.78%	4.02%	4.26%	4.29%	4.39%	4.41%	4.52%
	May-24	Jun-24	Jul-24	Aug-24	Sep-24	Oct-24	Nov-24	Dec-24	Jan-25
<b>Ventura County Pool</b>	4.56%	4.57%	4.51%	4.52%	4.60%	4.47%	4.58%	4.51%	4.46%

### Local Agency Investment Fund (LAIF)

Investment Name	Aug-23	Sep-23	Oct-23	Nov-23	Dec-23	Jan-24	Feb-24	Mar-24	Apr-24
<b>Local Agency Investment Fund (LAIF)</b>	3.43%	3.53%	3.67%	3.84%	3.93%	4.01%	4.12%	4.23%	4.27%
	May-24	Jun-24	Jul-24	Aug-24	Sep-24	Oct-24	Nov-24	Dec-24	Jan-25
<b>Local Agency Investment Fund (LAIF)</b>	4.33%	4.48%	4.52%	4.58%	4.58%	4.52%	4.48%	4.43%	4.37%

### Banc of California

Investment Name	Aug-23	Sep-23	Oct-23	Nov-23	Dec-23	Jan-24	Feb-24	Mar-24	Apr-24
<b>Banc of California</b>	0.04%	0.04%	0.04%	0.04%	0.04%	0.04%	0.04%	0.04%	0.04%
	May-24	Jun-24	Jul-24	Aug-24	Sep-24	Oct-24	Nov-24	Dec-24	Jan-25
<b>Banc of California</b>	0.04%	0.04%	0.04%	0.04%	0.04%	0.04%	0.04%	0.04%	0.04%

**PLEASANT VALLEY RECREATION AND PARK DISTRICT  
STAFF REPORT / AGENDA REPORT**

**TO: BOARD OF DIRECTORS**

**FROM: MARY OTTEN, GENERAL MANAGER**  
**By: Justin Kiraly, Administrative Services Manager**

**DATE: March 5, 2025**

**SUBJECT: FINANCE REPORT JANUARY 2025**

**ANALYSIS OF COMPARATIVE FINANCIALS THROUGH JANUARY 31, 2025**

The District's Statements of Revenues and Expenditures for the period of January 1, 2025, through January 31, 2025, with a year-to-date comparison for the period of January 1, 2024, through January 31, 2024, are attached. The percentage rate used is 58.3% for Period 7 of the current fiscal year. All dollar amounts as presented are rounded to the nearest whole dollar.

**REVENUES**

Total revenue including the 7<sup>th</sup> month ending January 31, 2025, for Fund 10 (General Fund) has an overall increase of \$495,276 in comparison to Fiscal Year 2023-2024. The variance from the prior year includes: 1) increase in Tax Apportionments (5110-5230) of \$278,149; 2) increase in Rentals (5530) of \$61,515, and 3) increase in Rebates Received (5574) of \$102,575. The property taxes increase was due to increased property values within the District. The increase in Rentals is due to increases in rental fees. The Rebates Received was from BE Water Wise for Turf Mitigation.

Total revenue recorded for Fund 20 for January 2025, the Assessment District Fund, was \$4,580 in interest earnings and \$2,037 in Assessment Revenue.

Total revenue recorded for Fund 30 for January 2025, the Quimby Fund, was \$61,135 in interest. Quimby funds are only collected when new housing developments are subdivided.

Total revenue recorded for Fund 40 for January 2025, the Park Impact Fees Fund, was \$8,116 in interest and no Park Impact Fees collected. Park Impact Fees are only collected when certain requirements are met whenever additional square footage is added to either residential or commercial properties.

Fund 50 Community Development Block Grant has been fully expended and reported. There is nothing further to report.

Fund 60 was established to keep donations made for a specific purpose/project separate from all other funds. There are no funds as of this report.

**EXPENDITURES**

Fund 10 Personnel Expenditures: Adjusting for the Unfunded Liability payment to CalPERS (6170) of \$515,039, there was an increase in salaries and benefits year-over-year of \$372,815. This is due to being fully staffed, as well as merit and cost of living increases. For the month of January,

there were 3 paychecks issued, as 26 pay periods leads to 2 months with 3 paychecks. This also contributes to the year over year increase.

Fund 10 Service and Supply Expenditures show an increase of \$206,002 in comparison to the same period last year.

Adjusting for reserves, the increase in Services and Supplies year-to-date is \$209,205. This increase includes Insurance Liability (6410) being \$46,528 more than last year, an increase in Business Services (7180) of \$47,711 due to the transition of Springbrook from an enterprise system to a cloud-based system and increased modules, and an increase in Utilities – Water (7820) of \$127,544 due to a drier and warmer first quarter of the year as well as increased water rates.

Fund 10 Capital Expenditures are at \$720,288 for the year: \$626,601 for the carryover Playground Replacement at Lokker Park, \$40,226 for the replacement of Variable Frequency Drives (VFD) in the irrigation pumps at PV Fields, and \$53,460 for the purchase of two fleet vehicles.

Fund 10 Total Expenditures year-to-date are \$1,192,980 more compared to this point last year. Non-capital expenditures are \$559,093 more than this point last year. A portion of this increase is due to three paychecks in January; in FY 2023-2024, the three paychecks were in February.

Fund 20 Total Expenditures are \$899,108 in Services and Supplies as of this month.

Fund 30 Expenditures are \$8,734 in Pickleball and \$48 in Freedom Park ADA Bathroom improvements for this month.

Fund 40 has \$36,286 in Administrative Fee expenditures to the Pleasant Valley Recreation and Park District.

### **FISCAL IMPACT**

Overall, the financials show the District is under the approved budget for Fund 10 by 46%, Fund 20 by 34%, and Fund 30 by 89%. Fund 40 has no budget.

### **RECOMMENDATION**

It is recommended the Board review and approve the Financial Statements for January 31, 2025, for Fund 10, Fund 20, Fund 30, and Fund 40.

### **ATTACHMENTS**

- 1) Financial Statement of Revenues and Expenditures as of January 31, 2025, Fund 10  
(2 pages)
- 2) Financial Statement of Revenue and Expenditures as of January 31, 2025, Fund 20  
(1 page)
- 3) Financial Statement of Revenue and Expenditures as of January 31, 2025, Fund 30  
(1 page)
- 4) Financial Statement of Revenue and Expenditures as of January 31, 2025, Fund 40  
(1 page)

General Ledger  
Fund 10 General Fund  
January 2025 58.3%

Account-Description	Period Amount	One Year Prior Actual	Year to Date	Budget	Budget Remaining	% of Budget Used
<b>Revenue</b>						
5110-5230 Tax Apportionment	\$ 264,823.43	\$ 4,710,093.02	\$ 4,988,241.70	\$ 8,877,226.00	\$ 3,888,984.30	56%
5310 - Interest Earnings	\$ 72,497.16	\$ 276,465.26	\$ 293,062.37	\$ 270,000.00	\$ (23,062.37)	109%
5502 - Carryover Balance	\$ -	\$ -	\$ -	\$ 75,000.00	\$ 75,000.00	0%
5506 - Park Patrol Citations	\$ 182.00	\$ 2,802.80	\$ 2,496.05	\$ 2,300.00	\$ (196.05)	109%
5508 - Bingo - Primary Revenue	\$ -	\$ 13,558.50	\$ 9,882.76	\$ 19,750.00	\$ 9,867.24	50%
5509 - Excess Bingo Revenue	\$ (845.50)	\$ 3,186.00	\$ 73.55	\$ 240.00	\$ 166.45	31%
5510 - Contract Classes-Public Fees	\$ 15,586.26	\$ 150,334.02	\$ 139,721.63	\$ 204,565.00	\$ 64,843.37	68%
5511 - Public Fees	\$ 1,823.50	\$ 215,720.34	\$ 202,639.79	\$ 364,429.00	\$ 161,789.21	56%
5520 - Public Fees-Entry Fees	\$ 4,144.00	\$ 28,911.50	\$ 26,560.00	\$ 41,600.00	\$ 15,040.00	64%
5525 - Vending Concessions	\$ -	\$ -	\$ 259.65	\$ 1,450.00	\$ 1,190.35	18%
5530 - Rental	\$ 60,041.79	\$ 425,163.93	\$ 486,679.30	\$ 690,023.00	\$ 203,343.70	71%
5535 - Cell Tower Revenue	\$ 13,215.48	\$ 96,143.83	\$ 103,610.82	\$ 166,109.00	\$ 62,498.18	62%
5540 - Parking Fees	\$ 672.66	\$ 19,505.06	\$ 19,073.28	\$ 10,350.00	\$ (8,723.28)	184%
5550 - Dues	\$ -	\$ -	\$ 125.00	\$ -	\$ (125.00)	-
5555 - Advertising Revenue	\$ 2,700.00	\$ 5,550.00	\$ 6,385.00	\$ 6,000.00	\$ (385.00)	106%
5558 - Sponsorships/Donations	\$ 6,750.00	\$ 4,057.47	\$ 13,114.32	\$ 5,000.00	\$ (8,114.32)	262%
5561 - Special Event	\$ -	\$ 22,303.19	\$ 30,652.33	\$ 129,700.00	\$ 99,047.67	24%
5563 - Staffing Cost Recovery	\$ 850.50	\$ 18,564.50	\$ 37,576.75	\$ 65,960.00	\$ 28,383.25	57%
5564 - Special Event Permits	\$ 100.00	\$ 1,790.00	\$ 1,150.00	\$ -	\$ (1,150.00)	-
5566 - Security Services - Recovery	\$ -	\$ 7,525.00	\$ 3,295.00	\$ -	\$ (3,295.00)	-
5570 - Contributions	\$ 68.00	\$ 509.82	\$ 925.39	\$ -	\$ (925.39)	-
5574 - Rebates Received	\$ -	\$ -	\$ 102,572.00	\$ -	\$ (102,572.00)	-
5575 - Other Misc Revenue	\$ 39,436.37	\$ 55,516.24	\$ 75,596.37	\$ 53,684.00	\$ (21,912.37)	141%
5576 - Restricted Donations	\$ 18,600.00	\$ 5,598.00	\$ 19,172.64	\$ -	\$ (19,172.64)	-
5585 - Incentive Income	\$ 19.10	\$ 872.67	\$ 1,775.02	\$ 1,700.00	\$ (75.02)	104%
5600 - Reimbursement - ROPS	\$ 420,349.98	\$ 566,645.76	\$ 561,451.71	\$ 560,000.00	\$ (1,451.71)	100%
<b>Revenue</b>	<b>\$ 921,014.73</b>	<b>\$ 6,630,816.91</b>	<b>\$ 7,126,092.43</b>	<b>\$ 11,545,086.00</b>	<b>\$ 4,418,993.57</b>	<b>62%</b>
<b>YTD Comparison</b>			\$ 495,275.52			
<b>Personnel</b>						
6100 - Full Time Salaries	\$ 350,993.62	\$ 1,456,023.70	\$ 1,717,745.72	\$ 3,094,949.00	\$ 1,377,203.28	56%
6101 - Overtime Salaries	\$ 3,983.34	\$ 11,459.02	\$ 12,701.71	\$ 28,035.00	\$ 15,333.29	45%
6105 - Car Allowance	\$ 692.28	\$ 5,778.64	\$ 3,461.40	\$ 6,000.00	\$ 2,538.60	58%
6108 - Cell Phone Allowance	\$ 2,039.00	\$ 7,719.07	\$ 9,674.00	\$ 18,070.00	\$ 8,396.00	54%
6110 - Part-Time Salaries	\$ 27,860.45	\$ 263,346.42	\$ 256,805.16	\$ 608,614.00	\$ 351,808.84	42%
6120 - Retirement	\$ 60,815.49	\$ 249,503.51	\$ 301,519.71	\$ 576,288.00	\$ 274,768.29	52%
6121 - 457 Pension	\$ 87.17	\$ 6,717.97	\$ 8,680.31	\$ 7,000.00	\$ (1,680.31)	124%
6125 - Deferred Compensation	\$ 599.19	\$ 2,796.22	\$ 2,995.95	\$ 5,592.00	\$ 2,596.05	54%
6130 - Employee Insurance	\$ 38,578.09	\$ 183,254.57	\$ 228,391.48	\$ 488,032.00	\$ 259,640.52	47%
6140 - Workers Compensation	\$ 20,547.70	\$ 86,099.61	\$ 103,538.02	\$ 192,345.00	\$ 88,806.98	54%
6150 - Unemployment Insurance	\$ -	\$ -	\$ -	\$ 10,000.00	\$ 10,000.00	0%
6170 - PERS Unfunded Liability	\$ -	\$ 494,762.00	\$ 515,039.00	\$ 582,241.00	\$ 67,202.00	88%
<b>Personnel</b>	<b>\$ 506,196.33</b>	<b>\$ 2,767,460.73</b>	<b>\$ 3,160,552.46</b>	<b>\$ 5,617,166.00</b>	<b>\$ 2,456,613.54</b>	<b>56%</b>
<b>YTD Comparison</b>			\$ 393,091.73			
<b>Services and Supplies</b>						
6210 - Telephone/Internet	\$ 6,223.60	\$ 12,926.29	\$ 17,529.77	\$ 23,720.00	\$ 6,190.23	74%
6220 - IT Services	\$ 4,147.35	\$ 36,968.88	\$ 41,209.12	\$ 72,199.00	\$ 30,989.88	57%
6230 - IT Hardware	\$ 77.61	\$ 448.95	\$ 5,913.24	\$ 7,200.00	\$ 1,286.76	82%
6240 - Software Services	\$ 3,223.50	\$ 37,178.11	\$ 24,218.03	\$ 45,854.00	\$ 21,635.97	53%
6310 - Pool Chemicals	\$ 1,159.64	\$ 2,993.59	\$ 4,922.60	\$ 7,250.00	\$ 2,327.40	68%
6320 - Janitorial Supplies	\$ -	\$ 34,502.95	\$ 28,505.06	\$ 68,343.00	\$ 39,837.94	42%
6330 - Kitchen Supplies	\$ 115.28	\$ 121.36	\$ 158.79	\$ 700.00	\$ 541.21	23%
6340 - Food Supplies	\$ 2,974.09	\$ 7,122.65	\$ 4,936.84	\$ 7,545.00	\$ 2,608.16	65%
6350 - Water Maint & Service	\$ 49.22	\$ 427.35	\$ 380.42	\$ 908.00	\$ 527.58	42%
6360 - Laundry/Wash Service	\$ 113.00	\$ 233.00	\$ 113.00	\$ 1,120.00	\$ 1,007.00	10%
6380 - Medical Supplies	\$ -	\$ -	\$ -	\$ 1,390.00	\$ 1,390.00	0%
6410 - Insurance Liability	\$ -	\$ 377,588.00	\$ 424,116.00	\$ 441,778.00	\$ 17,662.00	96%
6500 - Equipment Maintenance	\$ 1,610.79	\$ 1,629.02	\$ 1,755.58	\$ 4,000.00	\$ 2,244.42	44%
6510 - Fuel	\$ 4,568.24	\$ 36,038.20	\$ 33,522.33	\$ 58,204.00	\$ 24,681.67	58%
6520 - Vehicle Maintenance	\$ 6,876.04	\$ 26,711.54	\$ 25,700.65	\$ 41,910.00	\$ 16,209.35	61%
6610 - Building Repair	\$ 3,054.55	\$ 37,636.05	\$ 28,460.18	\$ 67,750.00	\$ 39,289.82	42%
6620 - HVAC Maintenance/Repa	\$ -	\$ 4,927.17	\$ 2,207.00	\$ 9,128.00	\$ 6,921.00	24%
6630 - Playground Maintenance	\$ -	\$ 5,515.14	\$ 10,869.70	\$ 35,000.00	\$ 24,130.30	31%
6710 - Grounds Maintenance	\$ 11,689.59	\$ 47,466.30	\$ 65,401.45	\$ 104,760.00	\$ 39,358.55	62%
6719 - Tree Care	\$ -	\$ 27,895.37	\$ -	\$ -	\$ -	-
6720 - Contracted LS Services	\$ -	\$ 198.40	\$ -	\$ -	\$ -	-
6730 - Contracted Pest Control	\$ -	\$ 2,400.00	\$ 3,000.00	\$ 7,200.00	\$ 4,200.00	42%
6740 - Rubbish & Refuse	\$ 7,954.19	\$ 35,106.94	\$ 47,352.55	\$ 92,763.00	\$ 45,410.45	51%
6750 - Vandalism/Theft	\$ -	\$ 1,147.53	\$ -	\$ 1,500.00	\$ 1,500.00	0%
6810 - Memberships	\$ -	\$ 14,315.00	\$ 15,077.94	\$ 17,052.00	\$ 1,974.06	88%
6910 - Office Supplies	\$ 1,080.74	\$ 11,832.93	\$ 8,844.17	\$ 33,950.00	\$ 25,105.83	26%
6920 - Postage Expense	\$ 358.95	\$ 11,827.46	\$ 13,655.98	\$ 20,200.00	\$ 6,544.02	68%
6930 - Advertising Expense	\$ -	\$ 535.00	\$ 174.44	\$ 3,540.00	\$ 3,365.56	5%
6940 - Printing Charges	\$ 573.19	\$ 4,223.20	\$ 4,457.46	\$ 13,121.00	\$ 8,663.54	34%
6950 - Bank & Registration Fees	\$ 2,210.66	\$ 555.13	\$ 18,634.12	\$ 33,920.00	\$ 15,285.88	55%
6960 - Approp Redev/Collection	\$ 135,625.57	\$ 472,118.07	\$ 498,873.11	\$ 728,891.00	\$ 230,017.89	68%



6980 - Minor Furn Fixture & Equip	\$ 3,418.42	\$ 14,147.71	\$ 4,954.62	\$ 9,437.00	\$ 4,482.38	53%
7010 - Fingerprint Fees (HR)	\$ -	\$ 638.00	\$ 432.00	\$ 3,360.00	\$ 2,928.00	13%
7020 - Fire & Safety Insp Fees	\$ -	\$ 304.00	\$ 328.80	\$ 6,675.00	\$ 6,346.20	5%
7030 - Permit & Licensing Fees	\$ 3,450.06	\$ 6,871.53	\$ 4,080.57	\$ 9,110.00	\$ 5,029.43	45%
7100 - Professional Services	\$ -	\$ 27,322.13	\$ 29,972.73	\$ 130,200.00	\$ 100,227.27	23%
7110 - Legal Services	\$ 6,185.87	\$ 40,578.75	\$ 17,572.87	\$ 96,000.00	\$ 78,427.13	18%
7115 - Typeset and Print Services	\$ 10,197.00	\$ 11,681.76	\$ 20,460.39	\$ 38,100.00	\$ 17,639.61	54%
7120 - Instructor Services	\$ 10,855.51	\$ 83,161.99	\$ 70,551.70	\$ 113,635.00	\$ 43,083.30	62%
7125 - PERS Admin Fees	\$ 129.38	\$ 991.22	\$ 848.98	\$ 2,200.00	\$ 1,351.02	39%
7130 - Audit Services	\$ -	\$ 7,750.00	\$ 12,050.00	\$ 17,425.00	\$ 5,375.00	69%
7140 - Medical & Health Svcs	\$ 768.00	\$ 1,800.00	\$ 1,700.44	\$ 10,720.00	\$ 9,019.56	16%
7150 - Security Services	\$ 991.00	\$ 3,869.63	\$ 4,684.00	\$ 7,122.00	\$ 2,438.00	66%
7160 - Entertainment Services	\$ -	\$ 4,723.26	\$ -	\$ 4,300.00	\$ 4,300.00	0%
7180 - Business Services	\$ 7,587.10	\$ 51,473.04	\$ 105,818.95	\$ 180,532.00	\$ 74,713.05	59%
7190 - Umpire/Referee Services	\$ -	\$ 965.00	\$ 1,620.00	\$ 1,700.00	\$ 80.00	95%
7210 - Subscriptions	\$ 31.97	\$ 1,183.58	\$ 222.70	\$ 3,017.00	\$ 2,794.30	7%
7310 - Rents & Leases - Equip	\$ 6,658.69	\$ 10,176.70	\$ 17,174.36	\$ 50,870.00	\$ 33,695.64	34%
7320 - Bldg/Field Leases & Rents	\$ -	\$ -	\$ -	\$ 60.00	\$ 60.00	0%
7410 - Division Supplies	\$ 5,641.59	\$ 13,667.14	\$ 25,917.33	\$ 35,940.00	\$ 10,022.67	72%
7420 - Program/Event Supplies	\$ -	\$ -	\$ 200.55	\$ 50.00	\$ (150.55)	401%
7430 - Bingo Supplies	\$ -	\$ 1,389.40	\$ 2,290.84	\$ 5,400.00	\$ 3,109.16	42%
7440 - Sporting Goods	\$ -	\$ 1,666.58	\$ 3,334.33	\$ 11,620.00	\$ 8,285.67	29%
7450 - Arts and Craft Supplies	\$ -	\$ -	\$ 431.86	\$ 1,575.00	\$ 1,143.14	27%
7460 - Training Supplies	\$ -	\$ -	\$ 126.36	\$ 4,770.00	\$ 4,643.64	3%
7500 - Small Tools	\$ 482.57	\$ 1,146.52	\$ 5,386.00	\$ 6,000.00	\$ 614.00	90%
7510 - Safety Supplies	\$ -	\$ 1,242.04	\$ 2,063.98	\$ 4,619.00	\$ 2,555.02	45%
7610 - Uniform Allowance	\$ 3,868.16	\$ 5,935.12	\$ 15,092.43	\$ 16,765.00	\$ 1,672.57	90%
7620 - Safety Clothing	\$ 990.33	\$ 777.13	\$ 2,789.85	\$ 6,450.00	\$ 3,660.15	43%
7710 - Conference&Seminar Sta	\$ 245.00	\$ 6,265.00	\$ 3,367.93	\$ 20,453.00	\$ 17,085.07	16%
7715 - Conference&Seminar Bo	\$ -	\$ 815.00	\$ -	\$ 2,475.00	\$ 2,475.00	0%
7720 - Conference&Seminar Tra	\$ -	\$ 3,240.13	\$ 3,191.73	\$ 5,854.00	\$ 2,662.27	55%
7725 - Out of Town Travel Board	\$ -	\$ 351.23	\$ 461.32	\$ 2,970.00	\$ 2,508.68	16%
7730 - Private Vehicle Mileage	\$ -	\$ 249.62	\$ 592.67	\$ 4,882.00	\$ 4,289.33	12%
7750 - Buses/Excursions	\$ -	\$ 7,728.43	\$ 4,652.85	\$ 12,200.00	\$ 7,547.15	38%
7760 - Tuition/Book Reimburse	\$ -	\$ -	\$ -	\$ 4,000.00	\$ 4,000.00	0%
7810 - Utilities - Gas	\$ 5,024.91	\$ 18,530.51	\$ 18,866.79	\$ 49,413.00	\$ 30,546.21	38%
7820 - Utilities - Water	\$ 77,011.36	\$ 445,291.02	\$ 572,834.57	\$ 905,155.00	\$ 332,320.43	63%
7830 - Utilities - Electric	\$ 12,625.82	\$ 118,849.18	\$ 119,450.95	\$ 236,994.00	\$ 117,543.05	50%
7840 - Airport Assessment Exp	\$ -	\$ -	\$ -	\$ 14,000.00	\$ 14,000.00	0%
7910 - Awards and Certificates	\$ 378.80	\$ 6,925.51	\$ 5,403.76	\$ 18,730.00	\$ 13,326.24	29%
7920 - Meals for Staff Training	\$ 190.01	\$ 615.85	\$ 665.52	\$ 3,500.00	\$ 2,834.48	19%
7930 - Employee Morale	\$ -	\$ 2,642.11	\$ 2,804.05	\$ 5,500.00	\$ 2,695.95	51%
7950 - COP Debt - PV Fields	\$ -	\$ 133,265.89	\$ 87,637.72	\$ 293,214.00	\$ 205,576.28	30%
7971 - Reserve Computer Fleet	\$ -	\$ 5,000.00	\$ 7,000.00	\$ 7,000.00	\$ -	100%
7973 - Reserve Dry Period	\$ -	\$ 65,203.00	\$ 50,000.00	\$ 50,000.00	\$ -	100%
7974 - Reserve Capital Imprvem	\$ -	\$ 20,000.00	\$ -	\$ -	\$ -	-
7975 - Reserve Repair/Oper/Adm	\$ -	\$ 20,000.00	\$ 50,000.00	\$ 50,000.00	\$ -	100%
7976 - Reserve - Compensated A	\$ -	\$ 25,000.00	\$ 25,000.00	\$ 25,000.00	\$ -	100%
<b>Services and Supplies</b>	<b>\$ 350,417.35</b>	<b>\$ 2,426,024.29</b>	<b>\$ 2,632,026.03</b>	<b>\$ 4,439,888.00</b>	<b>\$ 1,807,861.97</b>	<b>59%</b>
<b>YTD Comparison</b>			<b>\$ 206,001.74</b>			
<b>Capital</b>						
8400 - General Capital	\$ -	\$ 5,380.00	\$ -	\$ 200,585.00	\$ 200,585.00	0%
8420 - Equip/Facility Replaceme	\$ -	\$ -	\$ 53,459.91	\$ 55,000.00	\$ 1,540.09	97%
8502 - Freedom Dog Park	\$ -	\$ 3,868.74	\$ -	\$ -	\$ -	-
8507 - Lokker Playground	\$ 8,321.67	\$ 5,885.00	\$ 626,601.11	\$ 630,471.08	\$ 3,869.97	99%
8509 - PV Fields Sewer Lift Static	\$ -	\$ 111,267.13	\$ -	\$ -	\$ -	-
8517 - Community Center Alarm	\$ -	\$ -	\$ -	\$ 120,000.00	\$ 120,000.00	0%
8518 - Bob Kildee Parking Lot	\$ -	\$ -	\$ -	\$ 117,089.00	\$ 117,089.00	0%
8519 - Cam Grove Parking Lot	\$ -	\$ -	\$ -	\$ 110,063.00	\$ 110,063.00	0%
8520 - Cam Grove BBQ	\$ -	\$ -	\$ -	\$ 30,000.00	\$ 30,000.00	0%
8521 - Dos Caminos Parking Lot	\$ -	\$ -	\$ -	\$ 30,000.00	\$ 30,000.00	0%
8522 - Mel Vincent Parking Lot	\$ -	\$ -	\$ -	\$ 27,000.00	\$ 27,000.00	0%
8523 - Pitts Ranch Tennis Court I	\$ -	\$ -	\$ -	\$ 40,000.00	\$ 40,000.00	0%
8524 - Pitts Ranch Parking Lot	\$ -	\$ -	\$ -	\$ 25,000.00	\$ 25,000.00	0%
8525 - Calleguas Playground	\$ -	\$ -	\$ -	\$ 131,490.00	\$ 131,490.00	0%
8526 - PV Parking Lot	\$ -	\$ -	\$ -	\$ 186,000.00	\$ 186,000.00	0%
8527 - PV Field VFD Replacem	\$ 40,226.48	\$ -	\$ 40,226.48	\$ 50,000.00	\$ 9,773.52	80%
8528 - Springville Iron Fence Ref	\$ -	\$ -	\$ -	\$ 80,000.00	\$ 80,000.00	0%
8530 - Quito Playground	\$ -	\$ -	\$ -	\$ 202,925.00	\$ 202,925.00	0%
<b>Capital</b>	<b>\$ 48,548.15</b>	<b>\$ 126,400.87</b>	<b>\$ 720,287.50</b>	<b>\$ 2,035,623.08</b>	<b>\$ 1,315,335.58</b>	<b>35%</b>
<b>YTD Comparison</b>			<b>\$ 593,886.63</b>			
<b>Total Expenses</b>	<b>\$ 905,161.83</b>	<b>\$ 5,319,885.89</b>	<b>\$ 6,512,865.99</b>	<b>\$ 12,092,677.08</b>	<b>\$ 5,579,811.09</b>	<b>54%</b>
<b>YTD Comparison</b>			<b>\$ 1,192,980.10</b>			
<b>Revenue Total</b>	<b>\$ 921,014.73</b>	<b>\$ 6,630,816.91</b>	<b>\$ 7,126,092.43</b>	<b>\$ 11,545,086.00</b>	<b>\$ 4,418,993.57</b>	<b>62%</b>
<b>Expense Total</b>	<b>\$ 905,161.83</b>	<b>\$ 5,319,885.89</b>	<b>\$ 6,512,865.99</b>	<b>\$ 12,092,677.08</b>	<b>\$ 5,579,811.09</b>	<b>54%</b>
<b>YTD Revenue-Expenses</b>	<b>\$ 15,852.90</b>	<b>\$ 1,310,931.02</b>	<b>\$ 613,226.44</b>			
<b>YTD Comparison</b>			<b>\$ (697,704.58)</b>			

General Ledger  
Fund 20 Assessment Fund  
January 2025 58.3%

Account-Description	Period Amount	One Year Prior Actual	Year to Date	Budget	Budget Remaining	% of Budget Used
<b>Revenue</b>	\$ -	\$ -	\$ -	\$ -	\$ -	-
5310 - Interest Earnings	\$ 4,580.44	\$ 27,397.09	\$ 28,851.02	\$ 35,000.00	\$ 6,148.98	82%
5500 - Assessment Revenue	\$ 2,036.52	\$ 741,976.95	\$ 758,920.22	\$ 1,341,735.00	\$ 582,814.78	57%
<b>Revenue</b>	<b>\$ 6,616.96</b>	<b>\$ 769,374.04</b>	<b>\$ 787,771.24</b>	<b>\$ 1,376,735.00</b>	<b>\$ 588,963.76</b>	<b>57%</b>
<b>YTD Comparison</b>			\$ 18,397.20			
<b>Personnel</b>	\$ -	\$ -	\$ -	\$ -	\$ -	-
6100 - Full Time Salaries	\$ -	\$ 50,780.14	\$ -	\$ -	\$ -	-
6108 - Cell Phone Allowance	\$ -	\$ 132.93	\$ -	\$ -	\$ -	-
6110 - Part-Time Salaries	\$ -	\$ 3,749.34	\$ -	\$ -	\$ -	-
6120 - Retirement	\$ -	\$ 9,932.61	\$ -	\$ -	\$ -	-
6130 - Employee Insurance	\$ -	\$ 10,870.97	\$ -	\$ -	\$ -	-
6140 - Workers Compensation	\$ -	\$ 6,053.26	\$ -	\$ -	\$ -	-
<b>Personnel</b>	<b>\$ -</b>	<b>\$ 81,519.25</b>	<b>\$ -</b>	<b>\$ -</b>	<b>\$ -</b>	<b>-</b>
<b>YTD Comparison</b>			\$ (81,519.25)			
<b>Services and Supplies</b>	\$ -	\$ -	\$ -	\$ -	\$ -	-
6610 - Building Repair	\$ -	\$ 2,355.55	\$ -	\$ -	\$ -	-
6709 - Incidental Costs - Assess	\$ -	\$ 11,269.13	\$ 10,567.89	\$ 19,444.00	\$ 8,876.11	54%
6710 - Grounds Maintenance	\$ -	\$ 39,156.33	\$ 6,200.38	\$ 78,293.00	\$ 72,092.62	8%
6719 - Tree Care	\$ -	\$ 33,390.56	\$ 97,374.71	\$ 120,000.00	\$ 22,625.29	81%
6720 - Contracted LS Services	\$ 89,727.67	\$ 210,155.40	\$ 316,631.17	\$ 610,938.00	\$ 294,306.83	52%
6722 - Park Amenities - Assess	\$ -	\$ -	\$ 5,887.19	\$ 60,000.00	\$ 54,112.81	10%
6740 - Rubbish & Refuse	\$ -	\$ 1,894.78	\$ -	\$ -	\$ -	-
6950 - Bank & Registration Fees	\$ -	\$ -	\$ -	\$ 70.00	\$ 70.00	0%
6960 - Approp Redev/Collection	\$ -	\$ 1,844.30	\$ 1,892.17	\$ 3,500.00	\$ 1,607.83	54%
7310 - Rents & Leases - Equip	\$ -	\$ 846.65	\$ -	\$ -	\$ -	-
7950 - COP Debt - PV Fields	\$ -	\$ 408,779.69	\$ 460,554.69	\$ 460,555.00	\$ 0.31	100%
<b>Services and Supplies</b>	<b>\$ 89,727.67</b>	<b>\$ 709,692.39</b>	<b>\$ 899,108.20</b>	<b>\$ 1,352,800.00</b>	<b>\$ 453,691.80</b>	<b>66%</b>
<b>YTD Comparison</b>			\$ 189,415.81			
	\$ -	\$ -	\$ -	\$ -	\$ -	-
<b>Capital</b>	\$ -	\$ -	\$ -	\$ -	\$ -	-
<b>YTD Comparison</b>			\$ -			
<b>Total Expenses</b>	<b>\$ 89,727.67</b>	<b>\$ 791,211.64</b>	<b>\$ 899,108.20</b>	<b>\$ 1,352,800.00</b>	<b>\$ 453,691.80</b>	<b>66%</b>
<b>YTD Comparison</b>			\$ 107,896.56			
<b>Revenue Total</b>	<b>\$ 6,616.96</b>	<b>\$ 769,374.04</b>	<b>\$ 787,771.24</b>	<b>\$ 1,376,735.00</b>	<b>\$ 588,963.76</b>	<b>57%</b>
<b>Expense Total</b>	<b>\$ 89,727.67</b>	<b>\$ 791,211.64</b>	<b>\$ 899,108.20</b>	<b>\$ 1,352,800.00</b>	<b>\$ 453,691.80</b>	<b>66%</b>
<b>YTD Revenue-Expenses</b>		<b>\$ (21,837.60)</b>	<b>\$ (111,336.96)</b>			
<b>YTD Comparison</b>			\$ (89,499.36)			

General Ledger  
Fund 30 Quimby Fund  
January 2025 58.3%

Account-Description	Period Amount	One Year Prior Actual	Year to Date	Budget	Budget Remaining	% of Budget Used
<b>Revenue</b>						
	\$ -	\$ -	\$ -	\$ -	\$ -	-
5310 - Interest Earnings	\$ 61,134.88	\$ 236,248.71	\$ 194,154.56	\$ 200,000.00	\$ 5,845.44	97%
<b>Revenue</b>	<b>\$ 61,134.88</b>	<b>\$ 236,248.71</b>	<b>\$ 194,154.56</b>	<b>\$ 200,000.00</b>	<b>\$ 5,845.44</b>	<b>97%</b>
<b>YTD Comparison</b>			\$ (42,094.15)			
<b>Capital</b>						
	\$ -	\$ -	\$ -	\$ -	\$ -	-
8493 - Pickleball Sports Comple	\$ 8,733.56	\$ 152,575.21	\$ 24,173.37	\$ 1,100,000.00	\$ 1,075,826.63	2%
8504 - Multi-Generation Center	\$ -	\$ -	\$ -	\$ 1,000,000.00	\$ 1,000,000.00	0%
8510 - Senior Center Improve	\$ -	\$ 16,071.65	\$ -	\$ -	\$ -	-
8511 - Senior/Community Cente	\$ -	\$ -	\$ 312,958.35	\$ 355,964.00	\$ 43,005.65	88%
8513 - Community Ctr/Classroo	\$ -	\$ -	\$ -	\$ 244,193.00	\$ 244,193.00	0%
8529 - Freedom Park ADA Bathrc	\$ 48.49	\$ -	\$ 48.49	\$ 500,000.00	\$ 499,951.51	0%
<b>Capital</b>	<b>\$ 8,782.05</b>	<b>\$ 168,646.86</b>	<b>\$ 337,180.21</b>	<b>\$ 3,200,157.00</b>	<b>\$ 2,862,976.79</b>	<b>11%</b>
<b>YTD Comparison</b>			\$ 168,533.35			
<b>Total Expenses</b>	<b>\$ 8,782.05</b>	<b>\$ 168,646.86</b>	<b>\$ 337,180.21</b>	<b>\$ 3,200,157.00</b>	<b>\$ 2,862,976.79</b>	<b>11%</b>
<b>YTD Comparison</b>			\$ 168,533.35			
<b>Revenue Total</b>	<b>\$ 61,134.88</b>	<b>\$ 236,248.71</b>	<b>\$ 194,154.56</b>	<b>\$ 200,000.00</b>	<b>\$ 5,845.44</b>	<b>97%</b>
<b>Expense Total</b>	<b>\$ 8,782.05</b>	<b>\$ 168,646.86</b>	<b>\$ 337,180.21</b>	<b>\$ 3,200,157.00</b>	<b>\$ 2,862,976.79</b>	<b>11%</b>
<b>YTD Revenue-Expenses</b>		<b>\$ 67,601.85</b>	<b>\$ (143,025.65)</b>			
<b>YTD Comparison</b>			\$ (210,627.50)			

Date Received	Amount	Amount Earmarked	Developer	Development Case #	Amount Expended	Balance
7/31/14	\$ 615,709.00	\$ 720,600.00	AMLI Residential	Springville (RPD-173)	\$ 615,709.00	\$ -
1/31/15	\$ 2,250,489.70	\$ 2,250,489.70	Fairfield LLC		\$ 2,222,672.07	\$ 27,817.63
8/8/16	\$ 2,649,209.00	\$ 3,200,000.00	Comstock/Elacora Mission Oaks		\$ 2,023,538.11	\$ 625,670.89
8/10/16	\$ 474,353.00	\$ 629,500.00	KB Homes		\$ 231,108.98	\$ 243,244.02
6/7/18	\$ 21,612.25	\$ 21,612.25	Crestview		\$ 21,612.25	\$ -
6/27/18	\$ -	\$ -	Aldersgate Construction		\$ 146,682.55	\$ -
3/6/19	\$ 35,242.00	\$ 70,484.00	Habitat for Humanity	Barry St (RPD-203)	\$ -	\$ 35,242.00
9/12/19	\$ -	\$ -	Aldersgate Construction		\$ 92,200.46	\$ -
11/21/19	\$ 1,264,500.00	\$ 1,500,000.00	Shea Homes		\$ 48.49	\$ 1,264,451.51
7/29/22	\$ 2,840,447.45	\$ -	Williams Homes		\$ -	\$ 2,840,447.45
8/5/22	\$ 347,625.00	\$ -	Somis Ranch Phase 1		\$ -	\$ 347,625.00
10/20/22	\$ 278,100.00	\$ -	Somis Ranch Phase 2		\$ -	\$ 278,100.00
3/15/23	\$ 313,508.00	\$ -	Barry 60 LP		\$ -	\$ 313,508.00
	\$ 1,040,226.22	\$ -	Interest Account		\$ -	\$ 1,040,226.22
<b>Total</b>	<b>\$ 12,131,021.62</b>	<b>\$ 8,392,685.95</b>			<b>\$ 5,353,571.91</b>	<b>\$ 7,016,332.72</b>

General Ledger  
Fund 40 Park Impact Fee Fund  
January 2025 58.3%

Account-Description	Period Amount	One Year Prior Actual	Year to Date	Budget	Budget Remaining	% of Budget Used
<b>Revenue</b>						
	\$ -	\$ -	\$ -	\$ -	\$ -	-
5310 - Interest Earnings	\$ 8,116.39	\$ 46,674.29	\$ 63,423.04	\$ 65,000.00	\$ 1,576.96	98%
5450 - Park Impact Fees	\$ -	\$ 1,773,374.00	\$ 20,019.22	\$ -	\$ (20,019.22)	-
<b>Revenue</b>	\$ 8,116.39	\$ 1,820,048.29	\$ 83,442.26	\$ 65,000.00	\$ (18,442.26)	128%
<b>YTD Comparison</b>			\$ (1,736,606.03)			
<b>Services and Supplies</b>	\$ -	\$ -	\$ -	\$ -	\$ -	-
6951 - Administrative Fee	\$ 36,286.37	\$ -	\$ 72,572.75	\$ -	\$ (72,572.75)	-
<b>Services and Supplies</b>	\$ 36,286.37	\$ -	\$ 72,572.75	\$ -	\$ (72,572.75)	-
<b>YTD Comparison</b>			\$ 72,572.75			
<b>Total Expenses</b>	\$ 36,286.37	\$ -	\$ 72,572.75	\$ -	\$ (72,572.75)	-
<b>YTD Comparison</b>			\$ 72,572.75			
<b>Revenue Total</b>	\$ 8,116.39	\$ 1,820,048.29	\$ 83,442.26	\$ 65,000.00	\$ (18,442.26)	128%
<b>Expense Total</b>	\$ 36,286.37	\$ -	\$ 72,572.75	\$ -	\$ (72,572.75)	-
<b>YTD Revenue-Expenses</b>		\$ 1,820,048.29	\$ 10,869.51			
<b>YTD Comparison</b>			\$ (1,809,178.78)			

**PLEASANT VALLEY RECREATION AND PARK DISTRICT  
STAFF REPORT / AGENDA REPORT**

**TO: BOARD OF DIRECTORS**

**FROM: MARY OTTEN, GENERAL MANAGER**  
**By: Nick Marienthal, Park Supervisor**

**DATE: March 5, 2025**

**SUBJECT: CONSIDERATION AND APPROVAL OF REQUEST FOR PROPOSAL (RFP) FOR TREE TRIMMING AND TREE MAINTENANCE**

**BACKGROUND**

The District currently has 3,345 trees inventoried with an estimated value of \$16,917,340. Due to a lack of necessary equipment and staffing, the District began utilizing third-party tree maintenance contractors in 2008 to handle larger-scale tree trimming needs in the District. In 2017, the District entered into a five-year agreement with West Coast Arborist (WCA), which has since been extended three times. This agreement will expire July 1, 2025.

Since 2017, the District has completed the following:

- Conducted a complete inventory of all 28 parks, identifying a total of 3,345 trees
- Fully pruned 750 trees
- Initiated the second round of grid pruning
- Planted 154 new trees
- Managed the Charter Oak windrow including:
  - Removed 120 Eucalyptus trees
  - Pruned 200 Eucalyptus trees
  - Planted 75 new trees

It is important for the District to manage and maintain the overall health and preservation of its urban forest. When the contract first started, the District followed an 8–10 year grid pruning cycle. Due to budget increases, the cycle has since been reduced to a 7–8 year cycle, with the goal ultimate goal of achieving a 4-year cycle.

Charter Oak windrow Eucalyptus removals should be completed in approximately 7-10 years. Once this process is finished, the funds currently allocated for these removals can be reallocated to other critical areas of tree maintenance. This could include increasing the frequency and coverage of grid pruning, expanding full pruning efforts to more trees, planting additional new trees to enhance the urban canopy, and addressing emergency tree care needs. Additionally, these reallocated funds can support other maintenance strategies within the District. The approach of grid pruning not only enhances tree structure and shape but also plays a vital role in reducing the

potential for tree failure and minimizing the District's liability, making it a key component of the long-term management strategy.

### **ANALYSIS**

The District seeks to solicit its second Request for Proposal for tree trimming and maintenance services with the goal of continuing to ensure that trees within the District are maintained on an annual basis and recorded in the District's tree database.

The following is the scope of services to be provided in the agreement:

#### **Develop District-wide Tree Maintenance Schedule**

The Contractor shall develop a District-wide tree maintenance schedule covering all 28 parks. This schedule must align with industry best practices for specific species and environmental conditions within the District. The schedule should also factor in seasonal considerations, growth rates, and risk assessments to ensure timely and efficient tree care.

#### **Execute the District-wide Tree Maintenance Schedule**

Upon development of a District-wide tree maintenance schedule, the Contractor shall follow said schedule to ensure that trees within the District are maintained according to the agreed-upon schedule.

#### **Update and Maintain the District's Tree Database**

Contractor will update and maintain the District's tree database. This database serves as a critical tool for tracking tree locations, monitoring tree health, identifying high-risk trees, recording tree removals, and documenting newly planted trees.

#### **Provide Emergency Tree Maintenance and Tree Removal Services**

In the event of emergencies such as storm damage, tree failure, or other urgent safety concerns, the contractor shall provide on-call emergency tree maintenance and removal services at the District's request. The contractor must have the capacity to respond to minimize risks to public safety and infrastructure.

### **FISCAL IMPACT**

There is no fiscal impact with this action. Funding for tree maintenance is contained in the annual budget (Fund 20, line item 6719 - Tree Care).

### **RECOMMENDATION**

It is recommended that the Board of Directors approve the Request for Proposal for Tree Trimming and Tree Maintenance and allow staff to solicit bids.

### **ATTACHMENTS**

- 1) RFP – Tree Trimming and Tree Maintenance Services (60 pages)

# Pleasant Valley Recreation and Park District



March 6, 2025

## Re: Request for Proposals for Tree Trimming and Tree Maintenance Services

Dear Prospective Bidder,

The Pleasant Valley Recreation and Park District is soliciting Requests for Proposals (RFP) from qualified firms to perform tree trimming and tree maintenance services Districtwide. The selected firm will also be responsible for responding to the District's emergency tree issues.

The Pleasant Valley Recreation & Park District, an independent special district, was formed in January 1962 under the State Public Resource Code of California to provide quality programs, parks and facilities for the City of Camarillo and other surrounding unincorporated communities located on the South Coast of Ventura County, serving a growing population of more than 69,500 citizens. The District currently has approximately 3,300 park trees located within the District's right-of-way laid out over five distinct districts. The District follows standards and guidelines set forth by the American National Standards Institute (ANSI) for Tree Care Operations.

If you are interested in this opportunity, please complete the required forms in the enclosed RFP and deliver or mail the entire RFP and three copies in a sealed envelope clearly marked "Tree Trimming and Tree Maintenance Services Bid Proposal" to the address below.

Questions pertaining to the Scope of Work can be directed to Nick Marienthal, Park Supervisor at [nmarienthal@pvrpd.org](mailto:nmarienthal@pvrpd.org). All questions related to this RFP are due by Tuesday, April 15, 2025. Any requests for clarification or questions received after this date will not receive a response from the Pleasant Valley Recreation and Park District.

For more information and to obtain the required documents, please visit the Pleasant Valley Recreation and Park District, Requests for Proposals / Bids web page at <https://www.pvrpd.org/request-for-proposals-bids>. Request for Proposals will be received until 10:00 am on Tuesday, April 22, 2025.

Thank you for your time, effort, and interest in our Tree Maintenance Services.

Sincerely,

Nick Marienthal,  
Park Supervisor

Encl. RFP for Tree Trimming and Tree Maintenance Services

1605 E. BURNLEY ST. • CAMARILLO, CA 93010 (805) 482-1996 • FAX (805) 482-7591

**PLEASANT VALLEY RECREATION AND PARK DISTRICT  
REQUEST FOR PROPOSALS**

**For:**

**TREE TRIMMING AND TREE MAINTENANCE SERVICES**

**SPEC NO.TTMS-25-30**



**Proposal Release Date:**

Thursday, March 6, 2025

**Job Walk:**

Wednesday, March 19, 2025

10:00 AM at 1605 E. Burnley St.

Camarillo, CA 93010

**Questions Due by:**

Tuesday, April 15, 2025

5:00 PM

**Proposal Submittal Due**

**Date and Time:** Tuesday,

April 22, 2025

10:00 AM

**COMPLETE THE FORMS WITHIN THIS RFP AND DELIVER OR MAIL THE ENTIRE RFP AND THREE COPIES IN A SEALED ENVELOPE CLEARLY MARKED "TREE TRIMMING AND TREE MAINTENANCE SERVICES BID PROPOSAL" TO THE ADDRESS BELOW.**

A pre-proposal job walk will take place at 1605 E. Burnley St. Camarillo, CA 93010. Contractors are also encouraged to get familiar with the District's trees within the parks and public right-of-way.



# Table of Contents

<b>RFP INFORMATION</b>	<b>2</b>
<b>INTRODUCTION</b>	<b>2</b>
<b>BID SUBMISSION INSTRUCTIONS</b>	<b>2</b>
<b>INQUIRIES</b>	<b>3</b>
<b>SCOPE OF WORK</b>	<b>3</b>
<b>CONTRACT TERM</b>	<b>24</b>
<b>AWARD CRITERIA</b>	<b>24</b>
<b>TERMS AND CONDITIONS</b>	<b>26</b>
<b>DEFINITIONS</b>	<b>28</b>
<b>REQUIRED FORMS FOR SUBMITTAL</b>	<b>31</b>
<b>BID PRICE SHEET</b>	<b>31</b>
<b>DESIGNATION OF SUBCONTRACTORS</b>	<b>35</b>
<b>STATEMENT OF NON-COLLUSION BY CONTRACTOR</b>	<b>36</b>
<b>CONTRACTOR'S ORGANIZATION STATEMENT AND PERFORMANCE HISTORY</b>	<b>37</b>
<b>SAMPLE AGREEMENT</b>	<b>42</b>

# RFP INFORMATION

## INTRODUCTION

The Pleasant Valley Recreation and Park District (the "District") is soliciting proposals from qualified companies to perform tree trimming and tree maintenance services Districtwide. The selected firm will also be responsible for responding to the District's emergency tree issues. The terms Consultant/Contractor/Vendor will be referred to herein as "Contractor" in this Request for Proposals (RFP).

The District is seeking to award a tree trimming and tree maintenance contract for an initial term of five (5) years, with three (3) one-year (1-year) extension periods at the option of the District. The award will be made to the lowest responsive and responsible bidder.

## BID SUBMISSION INSTRUCTIONS

Include all costs associated with performing the Scope of Services described in this RFP. Contractor shall pay wages in accordance with State of California Department of Industrial Relations General Prevailing Wage Determination for Tree Trimming for Ventura County.

(Refer to <http://www.dir.ca.gov/OPRL/PWD/Determinations/Statewide/C-TT.pdf> for additional information.)

Complete all the required forms in this RFP and submit one (1) original and three (3) copies of this entire RFP to the District by the date and time stated on the coversheet of this RFP. This time and date is fixed and extensions will not be granted. Bid proposals received after the deadline will not be considered. Late submittals will be destroyed thirty (30) days after bid opening. **Bid Proposals shall be submitted in sealed envelopes clearly marked on the outside "Tree Trimming and Tree Maintenance Services Bid Proposal Spec No. TTMS-25-30."** Mail or deliver sealed bid proposals to:

US Mail / FedEx / UPS / Hand Delivery: Pleasant Valley Recreation and Park District 1605 E. Burnley St. Camarillo, CA 93010
--

Bid proposals in the form of telephone calls, facsimiles or e-mails will not be accepted. The District does not recognize the U.S. Postal Service, UPS, FedEx, or other carriers in determining the date and time the bid was received.

It is the responsibility of the bidder to carefully examine this RFP and any addenda, which, if issued, will be posted on the District's website.

Bid results are available upon request 2-3 business days after the bid opening. Posted bid prices are preliminary in nature and may not reflect the final cost calculation. No notification will be sent to unsuccessful bidders.

## **INQUIRIES**

Only the following individuals may be contacted during the procurement process:

Questions Pertaining to Scope of Work or any other questions	Name: Nick Marienthal, Park Supervisor Email address: <a href="mailto:nmarienthal@pvrpd.org">nmarienthal@pvrpd.org</a>
--	---

To provide adequate response time prior to the bid opening, all questions regarding this RFP must be submitted in writing to the appropriate person shown above by the time stated on the cover sheet of this RFP. If the issue materially affects the RFP, the information will be incorporated into an addendum and posted on the District's website.

**No letters or correspondence will be sent notifying prospective bidders of any modifications or clarifications to this RFP.**

## **SCOPE OF WORK**

The Contractor will be required to perform and complete the tree trimming and tree maintenance work by providing all labor, tools, transportation, equipment, materials and supplies necessary to complete all work in a professional, thorough and timely manner, in accordance with standards and specifications as contained in this Section "Scope of Work."

### **A. ANNUAL MAINTENANCE PROGRAM**

- 1) The Contractor shall be required to submit a work schedule based on the District's annual tree pruning requirements, tree removal and replacement program, and planting projects, as detailed in paragraph "F" of this Scope of Work section.

The bid shall include a recommended annual work plan, daily work schedules, personnel and vehicles that would be required to complete the annual maintenance program as described in paragraph "E" of this Scope of Work section.

Depending on the District's current and future tree trimming and tree maintenance needs, the scheduled work may require multiple crews to perform concurrently within the same time constraints.

- 2) The Contractor shall have competent working supervisors at each jobsite at all times when work is being performed. Each supervisor must be capable of communicating effectively both in written and oral English and hold the necessary certifications or credentials as described herein for that position. All supervisors must possess adequate technical background to ensure that all work is accomplished in accordance with the special provisions of this RFP.

## **B. EMERGENCY RESPONSE PROTOCOL**

- 1) The Contractor is required to have a Project Manager available by telephone on a twenty-four (24) hour basis that is assigned to provide direct and prompt attention to requests from the District for emergency and after-hours tree service requests.
  - a. The Contractor shall acknowledge tree related emergency calls during normal business hours of operation and after-hours within fifteen (15) minutes of the initial call by the District.
  - b. The response time for a crew to arrive on-site for tree-related emergencies during normal business hours of operation shall not exceed sixty (60) minutes.
  - c. The response time for a crew to arrive on-site for tree-related emergencies outside of normal business hours of operation shall not exceed two (2) hours.

Failure to meet these requirements for timely response to emergencies shall result in a \$500 penalty for each occurrence, as the actual liquidated damages incurred by the District in such occurrence cannot readily be ascertained at this time.

## **C. CONTRACTOR EMPLOYEE PROTOCOL**

- 1) The Contractor shall employ sufficient personnel qualified by reason of education, training and experience to discharge the services agreed to be performed by Contractor. Contractor shall provide service of the highest quality at all times, and personnel retained to perform this service shall be temperate, competent and otherwise fully qualified to fulfill the Contractor's obligations under the awarded contract.
- 2) All employees of the Contractor performing services shall be dressed in clean, unaltered uniforms with suitable company identification. No portion of the uniform may be removed while working. Employees not in uniform shall be immediately removed from the work area. The Contractor shall provide a standard uniform consisting of at least a shirt, complimenting pants, a belt and boots appropriate to the work. All shirts, jackets or safety vests shall be clearly marked with company identification and the name of the employee wearing the uniform in the field. Contractor's employees shall appear neat and well-groomed at all times. Contractor's employees shall wear brightly colored safety vests when operating machinery and/or while working within five hundred (500) feet of moving traffic or such other distance required by any applicable laws.
- 3) The Contractor's employees shall be subject to the following minimum requirements, skills, abilities and knowledge:
  - a. Have all proper licenses for the operation of equipment utilized by such employees.
  - b. Ability to operate and maintain equipment in accordance with the manufacturer's recommendations.
  - c. Mechanical ability to make required operator adjustments to the equipment being used.

- d. Knowledge of safety regulations as they relate to tree care and traffic control.
- e. American Red Cross Standard First Aid Certification (minimum of one member of each crew).
- f. Ability to communicate orally in English. Supervisor shall have ability to communicate in written English.
- g. Demonstrated knowledge of tree care and related operations.

## **D. TREE INVENTORY**

The District will provide its current GPS tree inventory of all Twenty-Eight (28) park sites.

- 1) Tree Location and Inventory Requirements
  - a. A GPS tree inventory shall be created using the District's standardized addressing system, covering all parks and open space areas.
  - b. The Contractor shall be required to create an ESRI ArcView/Arc GIS compatible "shape file" utilizing such data.
- 2) Mapping and Compatibility
  - a. The inventory must displace the location of all existing tree site and vacant tree site on the District's existing GIS base maps, which includes layers such as streets, parcels, addresses, right-of-way (ROW), and hardscape features
  - b. The data must be compatible with the latest version of Arc View.
  - c. Tree location accuracy shall be within one (1) foot.
- 3) Updates and Maintenance
  - a. The tree inventory must be verified and updated during each grid pruning cycle as determined by the District.
  - b. The District will provide a monthly list of all newly planted and/or tree removals, including GPS coordinates, to be incorporated into the system.
  - c. The Contractor will indicate whether each tree is classified as a Specimen or Heritage Tree.
  - d. The Contractor shall record the location and height of uplifted sidewalks during their grid pruning or other tree maintenance activities within the District's park system.
  - e. The District shall have real-time access to the updated data at all times, as outlined in Paragraph "Q" of this Scope of Work.
- 4) Measurement of Canopy Spread
 

As a part of the data collection process, the successful Bidder shall measure the canopy spread of each tree using either a laser rangefinder or a Roll-a-Tape, to the nearest foot, using a pre-established uniform protocol. This data shall be included in the inventory database in a format suitable for use by the District.
- 5) Tree Condition
  - a. General condition of individual trees
  - b. Pruning requirements (i.e., recommended pruning cycle)
  - c. Condition of surrounding hardscape (i.e. displacement, recent repairs)

## **E. FIVE YEAR TREE MAINTENANCE PLAN**

Within ten (10) months of contract award, Contractor will review Districtwide tree inventory and will provide the District with a Five-Year Tree Maintenance Plan (TMP). This plan will include the proposed annual grid trimming schedule outlining the plan for trimming each of the District's trees over a five-year cycle, with exception for trees designated for more frequent trimmings. The TMP will be a five-year prioritized plan that identifies trees that need to be removed and replaced, as well as filling of vacancies. The TMP will present three (3) tree species as options for each tree site recommended for replacement. The options will take into account any of the District's appropriate planning documents such as the District's General Plan and Street Tree Master Plan, as well as spacing concerns, area for planting, sidewalks, existing landscape, watering needs, etc. The TMP will include an estimated annual cost for each of the five years, for removal and replacement, assuming a 24" box replacement.

## **F. WORK QUALITY AND GENERAL STANDARDS**

All work performed by Contractor shall comply with good arboreal practice for the particular species of trees being trimmed, shall be consistent with the Pruning Standards as adopted by the International Society of Arboriculture, and/or "Pruning Landscape Trees" by U.C. Agricultural Extension Service #AXT-288. The Contractor shall also meet the requirements of the most current American National Standards, Z133-1-1972, entitled "Safety Requirements for Tree Pruning, Trimming, Repair or Removal," published by the American National Standard Institute, Inc., 1430 Broadway, New York, New York 10018.

The District's designated representative shall determine if the Contractor has met all trimming requirements, and payment shall not be made by the District for trimming that is not in accordance with the above standards.

Prior to beginning the work, the Contractor shall review with the District's designated representative the various methods, tools and work scheduling to be used on the specific project to be undertaken.

Any structural weakness, decayed trunk or branches, or split crotches or limbs discovered by the Contractor during the course of trimming shall be reported to the District's designated representative for determination of action, as soon as it is discovered. When working on a tree, the Contractor shall be responsible for the removal of all vines entwined in the tree or around its trunk, and for the removal of sucker growth from tree trunks.

Daily tree trimming operations shall commence no earlier than 7:00 AM and shall be completed each day no later than 4:30 PM.

The Contractor's quality of work for all trimming of trees shall be such that if a tree has been trimmed within the last twenty-four (24) months, and there is an issue such as a limb drop, dead branches, etc., the Contractor will respond as directed by the District's designated representative (whether emergency or standard response) at Contractor's own expense.

A work zone shall be established and maintained for each tree trimming or other operations. The Contractor shall use all appropriate methods used in the field of tree trimming and tree maintenance for establishing and maintaining such work zone. No person other than members of the Contractor's work crew may be allowed to enter such work zone. If any person enters such work zone, the Contractor shall immediately cease all work and operation of all equipment until the work zone is clear.

#### **G. PUBLIC NOTICING**

The Contractor shall supply and post standard signage, with professional quality graphics, approved by the District's designated representative, on the trunk of the tree at the work site at which work is to be performed, at least seventy-two (72) hours in advance of work with the signage clearly stating what type of work is to be done and what effect the work will have on parking availability at that particular site. Posting shall be affixed to the tree trunk using materials that do not cause permanent damage to the tree. In the event that a tree trunk is not available for posting, the Contractor shall affix the posting to a standard size safety cone and place that cone in the center of the parkway where a tree is to be planted or atop a stump that is scheduled for grinding.

#### **H. TOOL SANITATION**

On all trees, including palms, known or suspected to be diseased, pruning tools and cut surfaces shall be disinfected with a ten percent (10%) percent chlorine bleach solution after each cut and between trees where there is danger of transmitting the disease on tools. Fresh solution shall be mixed daily. Old solutions shall be disposed of through proper disposal methods. Dumping used of old bleach solutions on the ground or down the storm drain is strictly prohibited per the State Water Boards National Pollutant Discharge Elimination System (NPDES) Municipal Separate Storm Sewer System (MS4) Permit Order No.R4-2012-0175. It is unlawful for any person to discharge non-storm water discharges to the MS4 unless the discharger meets the requirements set forth in the NPDES MS4 Permit.

#### **I. WILDLIFE PROTECTION**

Prior to the commencement of any work in the vicinity of any tree, each tree shall be visually surveyed, from all sides, for the sole purpose of detecting the presence of bird nests or wildlife of any type. If a nest is found and is determined to be active, there shall be no work of any type in the tree in which the nest is found without the written permission of the District's designated representative. At no time shall any nest or wildlife be removed from its location. In the event that wildlife is accidentally displaced, the Contractor shall notify the Ventura County Animal Control Division and/or the nearest appropriate animal rescue facility for assistance.

## **J. PRE-INSPECTION**

Prior to the commencement of any work in the vicinity of any tree, the Contractor shall identify the location of utilities, irrigation components and/or any private property element(s) that could be compromised by any work activity. If identified, the Contractor shall take appropriate action to protect same. If, during the course of pre-inspection, the Contractor identifies damage that exists before the onset of work, the Contractor shall document the damages with photos and report such damage to the District's designated representative prior to commencing work in that area. All photo documentation shall have the time and date embedded. Any claim of damage that cannot be refuted by photo-documentation and/or a written report to the District's designated representative shall be considered the responsibility of the Contractor.

## **K. SETUP, OPERATIONS, EQUIPMENT STAGING**

The Contractor shall setup, operate and stage in a manner that presents the least amount of disruption to residents, businesses, the public and traffic flow. Outside of an emergency situation, at no time will multiple setups or equipment staging be allowed on both sides of a street within the same block. Equipment shall never be stored or left unattended on a public street, District facility or private property. The staging of equipment shall not be exempt from the work hour restrictions defined herein.

## **L. IDENTIFICATION AND REPORTING OF HAZARDS**

While performing work of any type, the tree worker should inspect for any obvious hazards related to trees, including uplifted sidewalk segments. All hazardous situations should be corrected or promptly reported to the District's designated representative. Any defective or weakened trees shall be reported to the District's designated representative. The Contractor will be responsible for providing the District with the location and height of the uplifted sidewalks as part of the GIS mapping inventory. This information will be updated, at a minimum, on a weekly basis.

## **M. RISK MANAGEMENT**

Tree work is a controlled task. At no time should work be performed so as to result in a loss of control incident (e.g. free-falling large limbs or trunk sections, hinge cutting to avoid use of ropes/hoisting equipment, lack of safety apparatus/equipment guards, improper use/loading of equipment). Failure to maintain control at all times shows a lack of planning and judgment, which is considered dangerous, and can result in serious injury or death. The Contractor will be held fully liable for any damages and/or injuries. In addition, the Contractor shall be responsible for the mitigation of any damages related to a loss of control incident, and indemnification and defense obligations of the District.



## **N. CLEANUP OF GREEN WASTE AND DEBRIS**

Limbs, logs or any other debris resulting from any tree operations shall be promptly and properly removed. The work area shall be kept safe at all times until all operations are completed. Under no circumstances shall the accumulation of brush, limbs, logs or other debris be allowed to pose a hazard to the public. During production trimming and removals, debris shall be removed from public rights of way and private property within one (1) hour of the completion of work on the tree from which the debris was generated. All trimming activities shall cease immediately if clean up equipment ceases to function or is not available (e.g. loader, roll off equipment, staff). Street rights of way shall not be used to stage unattended debris generated during standard work hours. All debris from tree operations shall be cleaned up each day before the work crew leaves the site. All lawn areas shall be raked, all streets/sidewalks shall be swept, and all brush, branches, or other debris shall be removed from the site. Areas are to be left in a condition equal to or better than that which existed prior to the commencement of tree operations. No material is to be allowed to enter any storm drain nor shall any member of the public be allowed into the work area. Under no circumstances shall any member of the public be allowed to collect, salvage, or remove any brush, limbs, logs or other debris from the work area.

## **O. DISPOSAL OF MATERIALS**

The Contractor shall provide to the District evidence of Recycling Credit under C.M.C. 8.08 for all green waste produced as a result of the Contractor's operations under the terms of an awarded contract. All green waste shall be reduced, reused, recycled, and/or transformed by the Contractor. Weight slips shall be required as proof of final disposal and must be submitted to the District with each demand for payment. All brush generated from tree trimming operations shall be recycled where practical.

### **1) Wood Chips**

Reducing shall include but not be limited to chipping, grinding, and/or shredding operations. Disposal is to be used as mulch on District property at the direction of the District's designated representative.

The District shall have first right of refusal as to the use of all disease-free wood chips generated from chipping, grinding, and/or shredding operations. Chips generated from trimming operations within the Pleasant Valley Recreation and Park District may be dumped and spread at a District designated site with written permission from the District's designated representative.

Wood waste generated from tree removals shall be chipped into pure wood chips with an even uniform size. Diseased trees shall not be commingled with regular trees in the creation of wood chips. The disease-free chips shall be dumped and spread in specified locations in the District at the direction of the District's designated representative. It is the responsibility of the Contractor to appropriately dispose of diseased trees.

## **P. RECORD KEEPING**

The Contractor shall provide and operate a computerized tree inventory system that is compatible with the current District inventory system and shall upload all historic data. The system shall be password accessible twenty-four (24) hours each day of the year via the internet. Historic tree inventory and work history data, to be provided to the District, shall be uploaded and operational within the Contractor's tree inventory system prior to the commencement of all tree service work under the terms of an awarded contract. Thereafter, the Contractor shall update and maintain the tree site specific, internet accessible, computerized tree inventory system to reflect changes in baseline data (e.g. species, height, diameter) and to record the date, cost and crew identity for any trimming, removal, planting or emergency response work that occurs at any tree site at which tree work is performed. The system shall be upgraded to reflect the removal and replacement of trees, as well as the addition of trees to the inventory. The system shall be capable of maintaining and displaying all past work histories for any and all tree sites in the inventory, both individually and collectively by query, as well as future scheduling to the extent known. All aspects of the system including, but not limited to, data entry, system maintenance, system hardware and/or software upgrades and server security and stability shall be the responsibility of the Contractor and shall be provided at no cost to the District. The system shall not be proprietary in the nature of its function and shall operate and interface with common computer software and web based applications, including the ability to export data into common spreadsheet applications. The records created for the District shall be the property of the District and shall be uploaded to the District's system no less than twice per week.

Tree site/task specific hardcopy backup data for any work that has occurred during a billing cycle shall accompany the invoicing for that period and shall be accessible for review on the internet based computerized tree inventory system prior to the submittal of invoicing for that work. Invoicing for work that does not meet the requirements defined herein will not be processed for payment until such time as the requirements have been satisfied.

Failure to meet and maintain the requirements for the computerized tree inventory system shall be grounds for termination of the awarded contract.

## **Q. ACCIDENT INVESTIGATION**

Any duty-related incident which results in any injury shall be reported to the District's designated representative within one (1) hour by the Contractor. The Contractor shall cooperate fully with the District in the investigation of any incident, injury or death occurring on District property including a complete written report submitted by the Contractor to the District's designated representative, or assignee, within twenty-four (24) hours following the occurrence.

Should any structure or property be damaged during a permitted or contracted tree operation, the persons conducting the work shall immediately notify the property owners and the District's designated representative within one (1) hour. The Contractor shall make all arrangements for repairs to damaged property within

forty-eight (48) hours, except utility lines, which shall be repaired the same working day. The Contractor shall be solely responsible for contacting all utilities, neighboring property owners, and contractors required to complete such repairs. Repairs on private property shall be made in accordance with the appropriate building code under permits issued by the City of Camarillo as applicable. Any damage caused by the Contractor shall be repaired or restored by the Contractor at the Contractor's expense to a condition similar or equal to that existing before such damage or injury, or the Contractor shall repair such damage in a manner acceptable to the District.

Special attention shall be made to existing irrigation systems, plant material, landscape features, lights and utility boxes in District parkways, parks and public landscape areas and in order to avoid damage. Any damage that occurs must be repaired on the same day that the damage occurs. The Contractor may self-perform such work on irrigation systems upon approval and acceptance of such work by the District's designated representative.

The Contractor's responsibility shall be continuous and not be limited to working hours or days.

## **R. INSPECTIONS**

The District's designated representative shall be furnished with every reasonable means for ascertaining full knowledge of the daily tree maintenance operations involving the workmanship, character of materials and equipment used and employed in the work. Each day, the Contractor shall be required to provide the District's designated representative, with a written schedule of all daily tree maintenance operations including but not limited to trimming, planting, removals, stump grinding, root pruning, and watering.

Inspection of the work shall not relieve the Contractor of any obligations to complete the work as outlined in this RFP. Defective work shall be made good even if the defective work was not pointed out during the initial inspection and the work was accepted for payment.

Any work found to be unacceptable by the District will be noted in writing to the Contractor. Upon receipt of notice of any deficiencies, the Contractor shall make a reasonable effort to correct the deficiencies within five (5) working days. If unacceptable conditions are not corrected within this time period the District shall have the right to deduct payment or have services performed by others at the Contractor's expense.

## **S. WITHHOLDING PAYMENT**

The District may withhold payment to such extent as may be necessary to protect the District from loss due to one or more of the following reasons:

- 1) Defective, unsatisfactory or inadequate work not corrected.
- 2) Claims filed or reasonable evidence indicating probable filing of claims.

- 3) Failure of the Contractor to make proper payments to subcontractors or for materials or labor.
- 4) A reasonable doubt that the awarded contract can be completed for the balance unpaid.
- 5) Property damage that resulted from an incident.

#### **T. MINOR MODIFICATIONS AND/OR ADDITIONAL WORK**

The District may modify this scope of work with the joint approval of the Contractor and the District's designated representative or assignee. All modifications shall be in writing.

- 1) In the event that the District should require additional work beyond the requirements of this scope of work, the Contractor shall perform all work based on the unit prices provided in the bid price sheet in this RFP.
- 2) Additional work may be added to the scope of work as the need arises. The Contractor shall perform all specified and approved additional work at the unit prices submitted in the bid price sheet in this RFP.
- 3) The Contractor will be required to demonstrate the ability to properly execute the expanded workload with the necessary increase in labor, materials and equipment needed to complete the additional work in a timely manner.

#### **U. GRID TREE PRUNING**

Any tree work performed on a District tree must be done according to the District's specifications. The criterion for pruning depends on the type or purpose of pruning.

- 1) General Specifications for hardwood tree pruning
  - a. The Contractor shall consult with the District's designated representative before making any cuts that could result in permanent disfigurement of the structure of any tree.
  - b. The Contractor shall prune trees to prevent branch and foliage interference with safe public passage. The Contractor shall maintain street clearance to a safe distance above the public right-of-way at a minimum of eighty-four (84) inches above the surface of a public sidewalk or pedestrian way. Exceptions are allowed for young trees, which would be irreparably damaged by such pruning action. If pruning to these standards would result in permanent disfiguration of a tree, the Contractor shall not prune the tree until such time direction is obtained from the District's designated representative.
  - c. The Contractor shall use best practices when removing a live branch and shall include pruning cuts in branch tissue just outside the branch bark ridge and collar, which are trunk tissue. If no collar is visible, the angle of the cut should approximate the angle formed by the branch bark ridge and the trunk.

- d. When removing a dead branch, the final cut should be made outside the collar of live callus tissue. If the collar has grown out along the branch stub, only the dead stub should be removed, the live collar should remain intact and uninjured.
- e. Whenever pruning involves the removal of limbs that are too large to hold securely in one hand during the cutting operation, the limb shall be cut off first at a point several feet beyond the intended final cut. The final cut shall be made in a manner to prevent unnecessary tearing back of the bark and wood. Cuts that result in tearing of tissue on limbs below cuts shall be corrected.
- f. All final tree pruning cuts shall be made in such a manner to favor the earliest possible covering of the wound by natural callus growth. Excessively deep flush cuts, that produce large wounds or weaken the tree at the cut, shall not be made. The branch collar should not be removed.
- g. All dead and dying branches and branch stubs shall be removed.
- h. All broken or loose branches shall be removed.
- i. Branches that are developing in such a manner as to become larger than the limbs they originate from shall be removed.
- j. When encountering limbs that are weighted with more foliage than the limb is likely to support, branches shall be selectively pruned toward the end of the limb in order to reduce end weight and thus decrease the likelihood of limb failure.
- k. Branches that create sight line conflicts with traffic control signs and/or devices shall be selectively pruned.
- l. Branches that are within five (5) feet of a structure shall be selectively pruned.
- m. Trees of sprout or sucker growth shall be cleared to a minimum height of ten (10) feet above ground level. Exceptions are allowed for young trees, which would be irreparably damaged by such pruning action.
- n. Trees shall be pruned to maintain a balanced appearance when viewed from the opposite side of the street immediately opposite the tree, unless authorized by the District's designated representative to do otherwise.
- o. All vines entwined in trees and on tree trunks shall be removed. Vine tendrils shall be removed without injury to trees. Vines include, but are not limited to, ivy and mistletoe.

- p. Tree limbs shall be removed and controlled in such a manner to cause no damage to other parts of the tree, or to other plants or property.
- q. All tools used on a tree known to contain an infectious tree disease shall be properly disinfected immediately before and after completing work on such tree.
- r. All pest infestations relating to termites, bees, hornets, or wasps shall be promptly reported to the District's designated representative.
- s. All cutting tools and saws used in tree pruning shall be kept sharpened to result in final cuts with an un-abrasive wood surface and secure bark remaining intact.
- t. All trees six (6) inches in diameter or less shall be pruned with hand tools only.
- u. Chain saws shall not be permitted to remove any branches two (2) Inches or less in diameter. This is to prevent any unnecessary abrasions to cambial tissue that may predispose a tree to insect and/or future disease/decay problems.
- v. Any extraneous metal, wire, rubber or other material interfering with tree growth shall be removed when possible.

The use of climbing spurs or spike shoes in the act of pruning trees is prohibited, unless specifically directed by the District, to aid in the safety of climbers performing the removal of a tree.

## 2) Crown Raising/Clearance Prune:

A Crown Raising or Clearance Prune is performed when conditions within the crown of a hardwood tree are such that a certain objective needs to be met or a certain condition needs attention. A crown raising or clearance prune does not involve the detail of work found in a full prune. Crown raising or clearance pruning may consist of one or more of the following pruning types:

- a. Crown Raising: Crown Raising consists of removing the lower branches of a tree in order to provide clearance for buildings, vehicles and pedestrians. It is important that a tree have at least one-half of its foliage on branches that originate in the lower two-thirds of its crown to ensure a well-formed, tapered structure and to uniformly distribute stress within the tree.
- b. Clearance Prune: Clearance Prune is employed as a means of eliminating limbs from the crown of a hardwood tree when an entire pruning of the tree is not warranted. Clearance pruning does not involve the fine detail work described herein as "full prune."

## 3) Pruning Specifications for individual Hardwood Species

- a. General Trimming and Shaping of Conifers

Two basic classes of conifers can be found in the District, those with branches radiating out from the trunk in whorls such as Pine trees or Cedar trees and those that sprout branches in a random manner such as Juniper or Taxus. Conifers shall typically be pruned in late winter or early spring. Typically, up to thirty percent (30%) of the live foliage may be removed unless directed otherwise by the District's designated representative.

1. The Contractor shall avoid damaging the central leader on all conifers. In specific cases the District's designated representative may direct the Contractor to remove the central leader in an effort to limit the height of specific trees.
2. At the time of pruning, the District's designated representative shall determine which trees shall have the new growth pinched back in an effort to control canopy size.
3. To control the growth of large mature conifers the Contractor shall be required to prune the new growth of lateral limbs.

Typical pruning of conifers shall consist of removing crossed limbs, deadwood or unwanted branches from the interior of the canopy.

b. General Trimming and Shaping of Broadleaf Trees

Follows the shape indicated by the natural growth habits of each tree species. Trimming and shaping of trees shall be as directed by the District's designated representative and in accordance with the following:

1. Cut to laterals to preserve the natural form of the tree, leaving the head open enough for the branching system to show and permitting the dead material to be easily cleaned out and light to show through the head. Tree foliage shall be reduced by at least twenty-five percent (25%) and up to thirty percent (30%).
2. In specific cases the District's designated representative may direct the Contractor to reduce the size of the tree crown in an effort to limit the height of specific trees.
3. Dead wood or weak, diseased, insect-infested, broken, low, or crossing limbs shall be trimmed and removed. Branches with an extremely narrow angle of attachment should normally be removed.
4. Small limbs, including suckers and waterspouts, shall be cut close to the trunk or branch from which they arise.

Heading cuts and/or topping shall not be allowed under any circumstances. Heading, rounding over, or stubbing shall not be an accepted practice for reducing the size or the framework of any tree.

**V. SPECIALTY PRUNE CLASSIFICATIONS FOR HARDWOOD TREES**

A Full Prune is performed when conditions within the crown of a hardwood tree are such that the entire tree needs to be fully pruned. Complete pruning is recommended when the primary objective is to maintain or improve tree health and structure, and includes pruning to reduce overall canopy mass and excessive wood weight. Trees that are identified for a Full Prune shall have no more than

thirty percent (30%) of the live foliage removed. A Full Prune typically consists of one or more of the following pruning treatments:

1. Crown Cleaning: Crown Cleaning or cleaning out is the removal of dead, diseased, crowded, weakly attached and low-vigor branches and water sprouts from the entirety of the tree crown. Care must be used to avoid stripping branches of all foliage at the interior of the tree crown. This practice, known as "lion tailing" disrupts the structural integrity of the tree, making it subject to limb and branch failure, especially during high winds.
2. Crown Thinning: Crown Thinning includes crown cleaning and the selective removal of branches to increase light penetration and air movement into and through the crown. Increased light and air stimulates and maintains interior foliage, which in turn improves branch taper and strength. Thinning reduces the wind-sail effect of the crown and the weight of heavy limbs. Care must be used to avoid stripping branches of all foliage at the interior of the tree crown. Thinning the crown can emphasize the structural beauty of the trunk and branches as well as improve the growth of plants beneath the tree by increasing light penetration. When thinning the crown of mature trees, up to thirty percent (30%) of the live foliage may be removed unless directed otherwise by the District's designated representative.
3. Crown Reduction: Crown Reduction is used to reduce the height and/or spread of a tree. Crown reduction varies from topping, a destructive practice, in that cuts are not made indiscriminately, resulting in large stubbed off limbs that are subject to decay. While reducing a crown, tree workers must adhere to basic tree trimming practices involving limb/branch size relationships and use of the branch bark collar to avoid the onset of decay at cut sites.
4. Crown Restoration: Crown Restoration is a corrective pruning used to restore the form of crowns that have been previously damaged. This treatment is best performed by tree workers who have a good understanding of the effects of pruning for the cultivation of tree canopies.

## **W. PALM TREE PRUNING**

Any tree work performed on a District tree must be done according to the District's specification. The criterion for pruning depends on the type or purpose of pruning. Palm Pruning consists of maintaining the crowns and trunks of palm trees including the pruning of spent or declining fronds, seed pods and the skinning or shaping of spent petiole bases into a ball or nut as applicable by palm type.

- 1) The specifications for the pruning of palm trees are as follows:
  - a. While making an approach to the palm crown for pruning, the Contractor shall inspect the trunk of the palm tree for signs of decay, insect frass, bird nesting or any other condition suggestive of a structural abnormality. Upon finding any condition suggestive of a structural abnormality of the



palm stem, the Contractor shall report to the District's designated representative immediately.

- b. Fronds shall be trimmed using a handsaw or pole saw that has been sterilized for no less than five (5) minutes by having the entirety of its cutting blade submersed in an equal solution of bleach and water before and after the handsaw is used to cut the fronds of any other palm tree.

At no time shall a chainsaw be used to prune any frond from any Canary Island Date Palm (*Phoenix canariensis*) in the District. The use of chainsaws to prune any frond from any Canary Island Date Palm will result in monetary penalties up to the cost of replacement of the palm.

Live, healthy fronds, initiating at an angle of ninety degrees (90°) or greater from the horizontal plane, shall not be removed. Fronds removed should be cut close to the petiole base, taking into consideration the role of petiole bases in the formation and maintenance of the ornamental ball at the base of the canopy, as applicable by species. Live trunk tissue should never be cut while pruning palm fronds.

- c. Using properly sterilized equipment as described herein, any fruit or flower structures in the crown of the palm shall be removed concurrently with frond pruning. At no time shall a chainsaw be used to cut any fruit or flower from any Canary Island Date Palm (*Phoenix canariensis*) in the District. The use of chainsaws to prune any fruit or flower structures from any Canary Island Date Palm shall result in severe penalties up to the replacement cost.

Care shall be taken in the handling of fruit and flowers as they are likely to release clear liquids that react with and can cause staining to hardscape elements. The Contractor shall be responsible for removing palm fruit related stains from private property hardscape elements.

- d. Maintenance of the ornamental ball located at the base of the palm canopy, directly below the live fronds, shall be as described by species as follows:
  1. Canary Island Date Palm (*Phoenix canariensis*): dead petiole bases shall be formed into an ornamental ball which begins directly below the lowest green fronds and acts to provide a base of support to the palm crown. This ornamental ball shall be uniform and smooth in appearance and shall extend no less than four (4) feet and no more than eight (8) feet below the lowest live frond in the crown. Ornamental balls with flattened or "stop sign" sides will not be accepted. The upper portion of the ornamental ball shall not taper in, resulting in a "pineapple" appearance as this treatment defeats the support capacity of the ball. The distal portion of the ball shall begin at a point flush with the periphery of the palm trunk and make a gradual taper upwards until it reaches the periphery of the shaped ornamental ball. While forbidden to use chainsaws for pruning fronds, fruit and flowers from any palm tree in the District, the Contractor may use a clean chainsaw in forming and/or shaping the

ornamental ball of a Canary Island Date Palm. The use of a sharpened shovel in shaping and maintaining ornamental balls often results in ornamental balls which have flat, un-tampered bottoms that are likely to relax and collapse into pedestrian and vehicular traffic zones with grave consequences.

The Contractor shall use care not to cut into live trunk tissue while maintaining the ornamental ball. The Contractor shall remove any foreign plant material that has sprouted in an ornamental ball. The Contractor shall verify that the ornamental ball meets the standard described herein each time a Canary Island Date Palm is pruned.

2. Date Palm (*Phoenix dactylifera*): spent petiole bases are left to form a supportive "base" below the lowest green fronds of the crown. Unlike the ornamental ball of a Canary Island Date Palm (*Phoenix canariensis*), the base does not require ornate shaping.

Instead, spent petiole bases are left uniformly long to form the base of the canopy, which shall extend no less than four (4) feet and no more than six (6) feet below the lowest live frond in the crown. While forbidden to use chainsaws for pruning fronds, fruit and flowers from any palm tree in the District, the Contractor may use a chainsaw in forming and/or shaping the base of a Date Palm by shortening a number of the lower petiole bases to bring the length of the nut to standard. The Contractor shall use care not to cut into live trunk tissue while maintaining the nut. The Contractor shall verify that the base meets the standard described herein each time a Date Palm is pruned.

3. Queen Palm (*Syagrus romanzoffianum*): loose petiole bases are to be removed each time the crown of a Queen Palm is maintained. Petiole bases that are attached to live trunk tissue shall be left undamaged.
4. King Palm (*Archontophoenix cunninghamiana*): loose petiole bases are to be removed each time the crown of a King Palm is maintained. Petiole bases that are attached to live trunk tissue shall be left undamaged.
5. Mexican Fan Palm (*Washingtonia robusta*): spent petiole bases are left uniformly long to form a base which shall extend no more than four (4) feet below the lowest live frond in the crown. Using hand tools, the Contractor shall skin the trunk area below the base clean without causing damage to live trunk tissue. The Contractor shall verify that the base meets the standard described herein each time a Mexican Fan Palm is pruned.
6. California Fan Palm (*Washingtonia filifera*): spent petiole bases are left uniformly long to form a nut which shall extend no more than eight (8) feet below the lowest live frond in the crown. Using hand tools,

the Contractor shall skin the trunk area below the base clean without causing damage to live trunk tissue. The Contractor shall verify that the base meets the standard described herein each time a California Fan Palm is pruned.

## **X. TREE REMOVAL**

Tree removal consists of the removal of the entirety of a hardwood tree or palm tree and the removal of its root system.

1. The Contractor shall comply with all general specifications standards described herein.
2. The price given by the Contractor for tree removals shall be inclusive of all staff, materials and equipment necessary to remove trees as described herein.
3. The Contractor shall identify the location of all utilities and private property landscape irrigation components prior to the removal of a tree and its root system. The Contractor shall notify the District's designated representative in writing of any condition that prevents the removal of a tree and/or the grinding of its root system. The Contractor shall take all responsibility for any damage that occurs once the process of removing a tree and/or associated root grinding begins.
4. The Contractor shall comply with wildlife protection standards described herein whenever removing a tree.
5. The Contractor shall not remove any tree without first confirming that the tree being considered is indeed the tree to be removed. Any confusion should be resolved by contacting the District's designated representative for assistance. The errant removal of trees shall be penalized up to the cost of the replacement.
6. During a tree removal, the Contractor shall maintain control of the tree and its parts at all times, which shall include the selection and use of proper techniques and equipment. At no time shall branches, limbs or tree trunks be allowed to freefall and create damage of any type. The Contractor will be held liable for loss of control incidents and shall pay for all damages and associated costs.
7. Cranes and other rigging equipment shall be properly certified, with evidence of such available for inspection prior to use of said equipment in the District. Crane operators shall be certified by the National Commission for the Certification of Crane Operators (NCCCO) and shall display current certification prior to operating a crane in the District. The use of cranes and certified operators shall not result in additional charges to the District beyond the unit price for the work being performed (e.g., the price for tree removal).

8. While loading and handling debris, the Contractor shall maintain control at all times so as not to result in damage to the public rights of way or private property. In addition, the Contractor shall not drop logs or trunks as to create undue noise or shock impact related damages to public and/or private property.
9. Except in hillside areas where the stump needs to remain for soil stability, in the event that the stump is not removed the same day as tree removal, the stump shall be removed as described herein, no more than thirty (30) days from the initial tree removal. The Contractor shall be responsible for maintaining a Tree Stump Removal List on a daily basis with such list provided to the District weekly. Should the removal of any stump not occur within the thirty (30) day period, the Contractor will remove the stump, within forty-eight (48) hours of notification by the District, at the Contractor's expense. Stumps, including the root flare shall be ground to a depth of no less than eighteen (18) inches. Surface roots shall be traced and ground to a depth of no less than eight (8) inches. Debris generated by stump grinding and root removal shall be removed from the site and replaced with a topsoil mix. Chips and stump grindings shall not be used as a backfill material.
10. As directed by the District's designated representative, trees on hillsides should be removed to a depth of one inch below grade, cut at the angle of the grade. The indentation shall be filled by the Contractor with wood chips.
11. The Contractor shall be responsible for the repair of any private property including any irrigation system components damaged during a tree removal or stump grinding. Repairs shall be made using components matching those that were damaged.

## **Y. TREE PLANTING AND YOUNG TREE CARE**

### **1. Tree Planting**

Tree planting consists of the installation of a nursery stock container or palm trees supplied by the Contractor.

- a. The Contractor shall comply with all general specifications standards described herein.
- b. As stated previously herein, the Contractor shall identify the location of all utilities and private property landscape irrigation components prior to the planting of any tree. The Contractor shall assume full responsibility for any damage that occurs during the planting of any tree.
- c. The Contractor shall supply quality nursery stock which is fully rooted and representative of recognized standards for size and quality of the tree being planted. The Contractor will provide the District with a copy of the bill of lading (or other such documentation) indicating the nursery from which the tree is purchased.

- d. Brown trunk height (BTH) for palm trees shall be measured from the top of the root ball to the lowest green frond attached to the trunk at an angle of ninety (90) degrees.
- e. Planting stock shall be well watered prior to shipping and covered during transport. Trees that are delivered uncovered, with a dry or fractured root ball or with broken scaffold limbs will be rejected. Root bound material will be rejected. Palms that are delivered uncovered, with a dry root ball or with a soilless root ball will be rejected.
- f. The Contractor shall not begin excavation for the planting of a tree without first confirming that the planting site being considered is indeed the site intended for the planting of a tree. Any confusion should be resolved by contacting the District's designated representative for assistance. In excavating planting pits, the Contractor shall not excavate deeper than the depth of the root ball of the tree being installed. The bottom of the planting pit shall be undisturbed so that the planted tree will not settle below top of root ball grade standards defined herein. As the width of the parkway allows, the Contractor shall excavate the planting pit to be two (2) times the width of the root ball of the nursery stock being planted.
- g. All nursery containers and box sides shall be removed from tree root balls prior to planting. The Contractor shall not install trees with box bottoms left on. All container debris (e.g. strapping, box fragments, and nails) shall be removed from the planting pit prior to backfilling.
- h. The Contractor shall install the tree or palm so that the top of the root ball is two (2) inches above the top of curb so that the trunk flare is completely exposed. In the event that there is no curb (i.e. park site), the Contractor shall install the tree or palm so that the top of the root ball is two (2) inches above the surrounding finished grade. The Contractor shall not resort to cutting or trimming the root ball as a means of meeting grade standards.
- i. The Contractor shall backfill hardwood tree plantings with an equal mix of excavated soil and topsoil. The topsoil portion of the backfill mix shall contain no more than ten percent (10%) well decomposed organic fines.
- j. The Contractor shall backfill palm plantings with one hundred percent (100%) washed mortar (plaster) sand.
- k. While backfilling, the Contractor shall cease backfilling when the planting pit is one-half (1/2) full, and apply water to remove air pockets from the backfill. Once the water has drained, the Contractor shall resume backfilling the planting pit. A watering basin shall be constructed in a uniform circle and shall extend from the center of the tree trunk to six (6) inches beyond the edge of the root ball. The top of the watering basin shall be graded and

maintained uniformly with the upper edge of the basin maintained at a grade of four (4) inches above the root flare of the tree.

- l. The Contractor shall be responsible for the stability of all planted trees. The nursery stake shall be removed from the trunk of the tree (as applicable) and the tree shall be double staked using two (2), two (2) inch lodge pole stakes of a length sufficient to be installed beyond the depth of the planting stock root ball and to extend to the lowest branches of the installed tree's crown. The stakes shall be installed an equal distance from the trunk of the tree and shall be installed perpendicular to the street or sidewalk and shall be installed so that one stake is orientated one hundred eighty degrees (180°) opposite the other stake. The root ball shall not be damaged by the installation of stakes. The stakes shall not be in contact with any aerial part of the tree. The trunk of the tree shall be attached to the stakes using District approved tree ties installed as per the manufacturer's specifications.
- m. The Contractor shall not use hoses, equipment or water from private properties while installing or watering parkway trees.
- n. If a new tree dies within a one (1) year period from planting, the Contractor shall replace it with a like specimen within seven (7) days of discovery, at the Contractor's expense.
- o. If a new tree is determined to be diseased within two (2) years of planting, the Contractor shall replace it with a like specimen, within seven (7) days of discovery, at the Contractor's expense.

## 2. New Tree Care

New Tree Care consists of the irrigation of young trees which have been installed by the Contractor and the cultivation of new canopy coverage. This irrigation will continue as directed by the District's designated representative.

- a. The Contractor shall comply with all general specifications standards described herein.
- b. As stated previously herein, the Contractor shall identify the location of all utilities and private property landscape irrigation components prior to the planting of any tree. The Contractor shall take all responsibility for any damage that occurs during the planting of any tree.
- c. The Contractor shall not use hoses, equipment or water from private properties when watering parkway trees.
- d. While performing tree watering, the Contractor shall maintain the tree watering basin to include the removal of weeds and debris and the

maintenance of the watering basin to size and grade standards defined herein.

- e. Trees shall be watered in such a manner that does not result in erosion of the tree watering basin, splashing of parked vehicles or damage to any of the tree's surroundings. Haphazard riggings and/or watering out of the window from the cab of watering equipment will not be tolerated.
- f. The Contractor shall maintain a daily log of trees watered. The log shall list the trees watered by site. A printed copy of the log, which shall be maintained in digital format, must accompany invoicing for tree watering services by the Contractor.

## **CONTRACT TERM**

The awarded contract term is five (5) years, effective from the date of execution of the contract, with the District's option to extend the contract on the same terms for three (3) additional one (1) year periods. The District shall not be required to provide "cause" or any reason whatsoever should it elect not to renew. The contract term and all extensions thereto shall not exceed a total of eight (8) years.

## **AWARD CRITERIA**

**General Provision** – The award of any contract shall be at the sole discretion of the District. It is the intent to make an award to one Bidder for all requirements although the District reserves the right to make multiple awards depending on the District's needs and what is in the best interest of the District. The District may accept or reject any or all bid proposals in whole or in part and may waive informalities in the process. The contents of the proposal of the selected Bidder will become the basis for a contractual obligation when the award of bid is made.

**Tree Maintenance Services Bid Award** – The District will award a contract to the lowest responsive and responsible bidder, provided that the Bidder is determined to be qualified based on the requirements listed herein. To determine the lowest bid, the District will review the Grand Total for each Bidder as indicated on the Bidder's Bid Price Sheet.

In order to be determined responsive, a Bidder must respond to all requested information and supply all required information in this RFP. Any bid may be rejected if it is conditional, incomplete or contains irregularities. Minor or immaterial irregularities in a bid may be waived. Waiver of an irregularity shall in no way modify this RFP nor affect recommendation for award of a contract.

**Grand Total Bid** - The grand total bid shall be calculated by adding the extended prices for all services as listed under General Services, Emergency Services, and Other Costs.

The extended prices shall be calculated by each Bidder and tallied for each service as well as each sub-total and the grand total. The extended prices are intended to show a potential amount of monthly service and are being used for the sole purpose of evaluating

unit service costs to determine the lowest bidder. Nothing in this RFP or in the estimated amount of units shown in the extended prices is intended to be nor shall be taken to be a guarantee of such amount of any work, or amount of compensation under any future contract. The successful Bidder shall be paid on the unit price only for work performed under the awarded contract executed by the successful Bidder and the District. The Contractor shall pay California Prevailing Wage Rates to all its employees.

The District will review only the grand totals for determination of the lowest Bidder, and will confirm the unit prices of the lowest Bidder for accuracy. If the apparent lowest Bidder is determined to have a mathematical error in the tabulation of the grand total, a subtotal, or an extended price, the District shall notify all bidders of such error and shall revise such Bidder's grand total to reflect the corrected sum.

### **REQUIRED QUALIFICATIONS**

Contractors submitting bids must hold both a valid State California C-27 (Landscaping) and a C-61/D49 (Limited Specialty/Tree Service) Contractor's License. Both licenses must be in good standing for the previous three (3) consecutive years without any official unresolved record of complaints registered or filed with the California Department of Consumer Affairs.

The Contractor shall have OSHA certification for aerial equipment to be used throughout the term of the awarded contract.

The Contractor's personnel must be qualified and trained in the tree maintenance industry. This will include the staffing of a project manager who shall be an ISA Certified Arborist, and fluent in the English language. At all times during contracted tree maintenance activities the firm shall have work crews on site that are represented by an English speaking supervisor who can receive and carry out instructions given by designated District representatives.

The Contractor shall be held liable for the faithful observance of any lawful instructions of the District, not in conflict with the awarded contract, which may be delivered to said party or representative at the work site.

The Contractor must keep all equipment in good working order and shall maintain and operate such equipment in full compliance with OSHA regulations and State of California Department of Transportation (DOT) requirements.

The Contractor should have at least three (3) similar and separate California governments or municipal multi-year tree maintenance contracts which have been successfully completed within the last ten (10) years. Each project shall be of comparable size and scope of this project (descriptions of these projects and contact persons must be provided with bid submission). These projects must also include work in tree inventories. The bid shall include a detailed description of their proposed inventory program along with sample reports.

At the time of award, the successful bidder must have staff that includes Certified Crane Operator(s) as recognized by the National Commission for the Certification of Crane Operators (NCCCO).



A submitted bid must include the required Contractor's Organization Statement and Performance History form found in the "Required Forms for Submittal" section of this RFP.

## **TERMS AND CONDITIONS**

**Applicable Laws** – The laws of the State of California will govern the awarded contract. The applicable law for any legal dispute arising out of the awarded contract shall be the law of the State of California. The Bidder shall comply with all federal, state, county and local laws concerning the type of services provided. All systems provided by the Bidder shall comply with all applicable federal, state, and local building, fire, safety, and electrical codes and all relevant industry standards.

**Equal Employment Opportunity** – The Bidder shall comply with all applicable state and federal laws addressing Equal Employment Opportunity.

**Conflict of Interest** – Except for items that are clearly promotional in nature, mass produced, trivial in value and not intended to invoke any form of reciprocation, employees of the District may not accept gratuities, entertainment, meals or anything of value whatsoever from current or potential service providers or suppliers. The offer of such gratuity to an employee of the District shall be cause for such service provider or supplier to be declared a non-responsible Bidder and prohibited from bidding, as provided in California Public Contract Code.

**Independent Contractor Status** – It is expressly understood that the Bidder named in any contract entered into by the District is acting as an "independent contractor" and not as an agent or employee of the District.

**Default of Contractor/Consultant** – The District shall hold the Bidder responsible for any damage that may be sustained by the District or third party because of the failure or neglect of the Bidder to comply with any term or condition listed herein.

**Permits and Licenses** – The Bidder shall secure and maintain in force during the term of any contract resulting from this RFP all licenses and permits required by law for the operation of its business, including a District business license.

**Appropriation of Funds** – If the term of the awarded contract extends into fiscal years subsequent to that in which it was approved, continuation of the contract is subject to the appropriation of funds for such purpose by the District Board. If funds to effect such continued payment are not appropriated, the Bidder agrees to discontinue providing any goods or service supplied to the District under the awarded contract.

**Assignment** – The Bidder shall, under no circumstances, assign any contract awarded as a result of this RFP by any means whatsoever, or any part thereof to another party without express written permission of the District.

**Award of Contract** – Award of any contract arising from any proposal submitted as a result of this RFP requires approval by the District Board as prescribed by District Ordinance. If the Contractor presents additional terms or conditions after a bid award has been made, such award shall be considered VOID.

**Submission of Signed Proposals** – Any bid proposal for which this RFP does not require submittal of a signed Bid Price Sheet, must include a signed proposal letter. The submission of proposals must be signed in longhand by the Bidder's authorized

representative. Submission of proposals by partnerships must be signed with the partnership name by the principal partner, followed by the signature and designation of the person signing. Submission of proposals by corporations must be signed under the legal name of the corporation by its president, secretary, or other person authorized to bind it in the matter. The name of each person signing shall be typed or printed below the signature.

**Addendum to the RFP** – If it becomes necessary to revise any part of this RFP, an addendum to this RFP will be posted on the District’s website. All addenda issued during the time of bidding will be incorporated into any resulting contract.

**Withdrawal of Proposal** – Any Bidder may withdraw its proposal, either personally or by written or facsimile request at any time prior to the time set for the Bid opening, provided that written confirmation of any facsimile with the signature of the Bidder is placed in the mail and postmarked prior to the time set for the opening thereof. Negligence on the part of the Bidder in preparing its proposal confers no right of withdrawal or modification of its proposal; after such proposal has been opened.

**Rejection of Proposals** – This RFP does not commit the District to award any contract. The District reserves the right, at its sole discretion, to reject any or all proposals without penalty, to waive irregularities in any proposals or in the RFP procedures, and to be the final judge as to which bids are responsive, responsible and most qualified. Any proposal that contains items not specified, items that are incorrect, has incomplete portions of items scheduled, or does not respond to items in the manner specified in this RFP may be considered non-responsive and may be rejected on these bases at the sole discretion of the District. Proposals offering less than 90 days for acceptance from the proposed Bid Due Date may be considered non-responsive and may be rejected. Non-award of any proposal will not imply any criticism of the proposal or convey any indication that the proposal was deficient. Non-award of any proposal will mean that either another proposal was deemed to be a lower cost or terms more advantageous to the District, or that no proposal was deemed acceptable.

**Public Information** – After the date specified for the opening of this RFP, all materials received relative to general service proposals become public information and are available for inspection. Professional service proposals become available to the public upon the award of contract. The District reserves the right to retain all proposals submitted.

**Bidder's Cost to Develop Proposal** – Costs for developing a proposal in response to this RFP are entirely the obligation of the Bidder and shall not be chargeable in any manner to the District.

**News Releases** – The Bidder shall not make news releases pertaining to an award resulting from proposals made in response to the RFP without the prior written approval of the District. In addition, the successful Bidder must agree not to release any advertising mentioning the District or quoting the opinion of any District employee without written approval by the District.

**Right to Negotiate Proposals** – The District reserves the right to negotiate any price or any provision, accept any part, or all parts of any and all proposals as determined to be in the best interest of the District and the taxpaying public. Bidders are encouraged to submit their best prices in the proposal as negotiations, if applicable, may only occur with the

lowest responsible bidder for general services. For professional services, fees may be negotiated with the most qualified proposer.

## **DEFINITIONS**

The following words, terms and phrases have the meanings ascribed to as follows:

Lowest responsible bidder. In addition to price, the "lowest responsible bidder" will be determined by consideration of the following factors:

- (1) The quality, availability and suitability of the supplies, equipment or services to the particular use required.
- (2) The ability, capacity and skill of the bidder to perform the service required.
- (3) Whether the bidder has the financial resources and facilities to perform or provide the service promptly, or within the time specified, without delay or interference.
- (4) The character, integrity, reputation, judgment, experience and efficiency of the bidder.
- (5) The bidder's record of performance or previous contracts or services, including compliance by the bidder with laws and ordinances relating to such contracts or services.
- (6) The ability of the bidder to provide future maintenance and service for the use of the equipment or materials to be purchased.
- (7) The scope of conditions attached to the bid by the bidder.

Most qualified bidder. The "most qualified bidder" will be determined by consideration of the following factors:

- (1) Qualifications, background, and prior experience of the firm in performing services for similar projects.
- (2) Experience, organization, and technical skills to successfully accomplish the project's scope of services and objectives.
- (3) Overall project design and methodology.
- (4) The responsiveness of this RFP to the tasks to be performed as identified in the Scope of Services section.
- (5) The timeliness and speed with which the Bidder can complete the scope of work.
- (6) The comprehensiveness and rationale of the project work plan.
- (7) Past performance on contracts with business or government agencies in terms of quality of work and compliance with schedules. This will be evaluated based on a check of references.
- (8) An evaluation of the approach and related costs.

Non-responsive bidder means an offer, submitted by a bidder, to furnish supplies, equipment or services that are not in conformity with the specifications, delivery terms or conditions or other requirements specified in this RFP.

Non-responsible bidder is a bidder that provides a bid but fails to demonstrate their capacity (financial or otherwise) to provide the supplies, equipment or service as specified in this RFP.

Professional services means those services provided by an individual, firm, partnership, or corporation as an independent contractor and which are of a technical and/or unique nature which require persons who are exceptionally qualified by education or experience to perform administrative, technical or advisory services which do not involve the delivery of a specific end product other than reports, plans, documents or specifications. By way of illustration but not limitation, the following services are considered as professional: general management consulting, personnel consulting, architecture, accounting, land surveying, landscape architecture, law, medicine, engineering, and research, studies of government operations and procedures and training. Services exempt from this definition include various types of testing services, real estate appraisers, equipment repair specialists, janitorial services and security service.

Responsible bidder: means a bidder who submits a responsive bid and who is not only financially responsible, but also possesses the resources, judgment, skill, ability, capacity and integrity requisite and necessary to perform the awarded contract according to its terms.

Responsive bid means a proposal, submitted by a responsible bidder, to furnish supplies, equipment or services in conformity with the specifications, delivery terms and conditions and other requirements specified in this RFP.

Services means any and all services, including but not limited to the repair or maintenance of equipment, machinery and other property. This term does not include services rendered by District officers or employees or architectural or other professional services which by their nature do not lend themselves to normal competitive procedures.

**This Page Has Been Left Blank Intentionally**

# REQUIRED FORMS FOR SUBMITTAL

## BID PRICE SHEET

The Contractor understands the tree population of the Pleasant Valley Recreation District and agrees to provide the specific services to the District as listed in the Bid Proposal.

**1. GRID OR ANNUAL TREE TRIMMING**

A systematic tree trimming program composed of existing grid or pre-designed districts that are trimmed in their entirety on a set schedule. Trees in a grid will include all large, medium and small trees. All trimming is performed in accordance with the standards established by the international Society of Arboriculture, American National Standards Institute and the City.

<b>UNIT</b>	<b>UNIT PRICE</b>
Per tree	\$

**2. FULL TRIM BASED ON SERVICE OR SPECIAL REQUESTS**

Trees requiring service prior to their regularly scheduled grid or annual trim to rectify a specific problem such as blocking street lighting or signs, right-of-way clearance for utility lines, or broken limbs will be performed as a "Service Request."

<u>Size</u>	<u>Unit</u>	<u>Unit price</u>
0-6" dbh	per tree	\$ _____
7-16" dbh	per tree	\$ _____
17-24 dbh	per tree	\$ _____
25-36 dbh	per tree	\$ _____
37 dbh & over	per tree	\$ _____

**3. PALM TREE TRIMMING**

	<u>Unit</u>	<u>Unit price</u>
Coco Palm, any size	per tree	\$ _____
Washingtonia Palm, any size	per tree	\$ _____
Canary Island Date Palm, any size	per tree	\$ _____

**4. TREE REMOVAL**

	<u>Unit</u>	<u>Unit price</u>
Complete tree and stump removal	per dbh	\$ _____
Tree removal only	per dbh	\$ _____
Stump only removal	per dbh	\$ _____

**5. TREE PLANTING**

	<u>Unit</u>	<u>Unit price</u>
15 gallon tree with root barrier	per tree	\$ _____
15 gallon tree without root barrier	per tree	\$ _____
24 inch box tree	per tree	\$ _____
24 inch box tree without root barrier	per tree	\$ _____

**6. TREE WATERING**

<u>Unit</u>	<u>Per day</u>	<u>Unit price</u>
per tree	\$	\$

**7. CREW RENTAL**

Per man hour  
\$

Standard maintenance crew of three (3) persons, one (1) chipper truck, one (1) aerial tower truck and chipper and all necessary saws and hand tools

**8. CREW RENTAL (overtime)**

Per man hour  
\$

Standard maintenance crew of three (3) persons, one (1) chipper truck, one (1) aerial tower truck and chipper and all necessary saws and hand tools.

**9. EQUIPMENT RATES**

List additional equipment you have available and the rates for each.

**10. MATERIAL AT COST PLUS \_\_\_\_\_ 15%**

**11. ARBORIST SERVICES**

Per hour \$

Arborist services provided by the hour as prescribed per the Special Provisions of these Specifications.

**12. EMERGENCY CREW RENTAL**

Per hour \$

**13. TREE MASTER PLAN**

Lump Sum \$

TOTAL ANNUAL AMOUNT OF BID (IN WORDS):

---

---

Submission of bid and signature of representative of Contractor below shall bind Contractor to perform stated services at the Unit Prices specified for duration of the term of the awarded contract.

**CONTRACTOR**

\_\_\_\_\_  
Company Name of Bidder

\_\_\_\_\_  
Authorized Signature

\_\_\_\_\_  
Date

\_\_\_\_\_  
Print Name

\_\_\_\_\_  
Title

\_\_\_\_\_  
Social Security or Taxpayer ID Number



**DESIGNATION OF SUBCONTRACTORS**

A bidder proposing to subcontract any portion of the work and to procure materials and equipment from suppliers and vendors shall identify all proposed subcontractors, suppliers and vendors below.

NAME, ADDRESS, AND PHONE NUMBER OF SUBCONTRACTORS, SUPPLIERS, AND VENDORS	TYPE OF WORK MATERIALS, OR EQUIPMENT (BE SPECIFIC)
_____	_____
_____	_____
_____	_____
_____	_____

Note: Additional sheets may be attached.

**STATEMENT OF NON-COLLUSION BY CONTRACTOR**

The undersigned who submits herewith to the Pleasant Valley Recreation and Park District a Bid or proposal does hereby certify that:

- a. All statements of fact in such bid or proposal are true;
- b. Such bid or proposal was not made in the interest of or on behalf of any undisclosed person, partnership, company, association, organization or corporation;
- c. Such bid or proposal is genuine and not collusive or sham;
- d. Bidder has not, directly or indirectly by agreement, communication or conference with anyone, attempted to induce action prejudicial to the interest of the Pleasant Valley Recreation and Park District or of any other bidder or anyone else interested in the proposed procurement;
- e. Bidder did not, directly or indirectly, collude, conspire, connive or agree with anyone else that said bidder or anyone else would submit a false or sham bid or proposal, or that anyone should refrain from bidding or withdraw his bid or proposal;
- f. Bidder did not, in any manner, directly or indirectly seek by agreement, communication or conference with anyone to raise or fix the bid or proposal price of said bidder or of anyone else, or to raise or fix any overhead, profit or cost element of his bid or proposal price, or that of anyone else;
- g. Bidder did not, directly or indirectly, submit his bid or proposal price or any breakdown thereof, or the contents thereof, or divulge information or data relative thereto, to any corporation, partnership, company, association, organization, bid depository, or to any member agent thereof, or to any individual or group of individuals, except to the Pleasant Valley Recreation and Park District, or to any person or persons who have a partnership or other financial interest with said bidder in his business.
- h. Bidder did not provide, directly or indirectly to any officer or employee of the Pleasant Valley Recreation and Park District any gratuity, entertainment, meals, or anything of value, whatsoever, which could be construed as intending to invoke any form of reciprocation or favorable treatment.
- i. No officer or principal of the undersigned firm is employed or has been employed, either full or part time, by the Pleasant Valley Recreation and Park District, either currently or within the last two (2) years, or is related to any officer or employee of the District by blood or marriage within the third degree. An exception to this section may be granted by approval of the District Board prior to contract award.
- j. No officer or principal of the undersigned firm nor any subcontractor to be engaged by the principal has been convicted by a court of competent jurisdiction of any charge of fraud, bribery, collusion, conspiracy or any other act in violation of any state or federal antitrust law in connection with the bidding on, award of, or performance of, any public work contract, with any public entity, within the last three years.

I certify, under penalty of perjury under the laws of the State of California that the foregoing is true and correct and that this certification was executed on \_\_\_\_\_ at \_\_\_\_\_, California. (Date)

(Location)  
Business:

\_\_\_\_\_  
(Signature)

Printed Name & Title: \_\_\_\_\_

## CONTRACTOR'S ORGANIZATION STATEMENT AND PERFORMANCE HISTORY

The term "Owner" herein shall refer to any private firm or public agency to which the Contractor has submitted a bid to, or contracted with, for any tree trimming and maintenance contract.

Submitted By: \_\_\_\_\_  
Name must correspond with the Contractor's License

\_\_\_\_\_ Corporation \_\_\_\_\_ Partnership \_\_\_\_\_ Individual \_\_\_\_\_ Joint Venture

If a corporation, under the laws of what State is it organized? \_\_\_\_\_

California Regional Office (s): \_\_\_\_\_

Officers, Responsible Managing Officers, Responsible Managing Employees: \_\_\_\_\_

Use a page titled "Additional Information and/or Comments" for providing requested or additional information for each of the following questions to which you answer "yes" or for any comments.

A. Provide the following license numbers and expiration dates:

CA Contractor's License No. \_\_\_\_\_ Expiration Date: \_\_\_\_\_

CA C-27 (Landscaping) Contractor's License No. \_\_\_\_\_ Expiration Date: \_\_\_\_\_

CA C-61/D49 (Limited Specialty/Tree Service) Contractor's License No. \_\_\_\_\_  
Expiration Date: \_\_\_\_\_

Will you be able to provide OSHA Certification for aerial equipment when used throughout the term of the awarded contract? Yes \_\_\_\_\_ No \_\_\_\_\_

B. How many years' experience in construction work as a current organization?

(1) As a General Contractor? \_\_\_\_\_ From \_\_\_\_\_ to \_\_\_\_\_

(2) As a Subcontractor? \_\_\_\_\_ From \_\_\_\_\_ to \_\_\_\_\_

C. ~~Provide the following names, addresses, and phone numbers for three public agencies for which Bidder~~ has performed similar work within the past ten (10) years, including the Geographical Information System (GIS) tree inventory services:

1.

Agency Name  
\_\_\_\_\_

Name and telephone number of person familiar with project

Contract amount

Type of work

Date Completed

2.

Agency Name

Name and telephone number of person familiar with project

Contract amount

Type of work

Date Completed

3.

Agency Name

Name and telephone number of person familiar with project

Contract amount

Type of work

Date Completed

- D. Have you, your company, or any officer, manager or partner thereof, failed to complete a contract for an Owner? YES \_\_\_\_ NO \_\_\_\_\_. If so indicate the name of each Owner, dates, and the circumstances.
- E. Have you, your company, or any officer, manager or partner thereof, previously had a contractor's license suspended or revoked? YES \_\_\_\_ NO \_\_\_\_\_. If so indicate the name of **each person** whose license was suspended or revoked, dates of occurrence, and the circumstances for each.
- F. Have you, your company, or any officer, manager or partner thereof, been debarred by any public agency? YES \_\_\_\_ NO \_\_\_\_\_. If so, for each incident, indicate the name of each person, the agency involved, dates, and the circumstances for each.
- G. In an award based on low-bid criteria where your firm appeared to have the low bid, have you or your company been denied an award of an Owner contract? YES \_\_\_\_ NO \_\_\_\_\_. If so, as to each such denial, state the name of the Owner, the date of the denial, the title and number of the contract bid, and the grounds on which the Owner based the denial of award.
- H. Has your company been the subject of any inquiry by any Owner as to whether your company is a non-responsible bidder or non-responsible Bidder? YES \_\_\_\_ NO \_\_\_\_\_. If so, as to each inquiry, state the name of the Owner, the date of the inquiry, the grounds on which the Owner based the inquiry, and the result of the inquiry.
- I. Has your company been given a notice of deficiency during the performance of a contract for these types of services? YES \_\_\_\_ NO \_\_\_\_\_. If so, as to each notice of deficiency, state the name of the Owner, the date of the notice, the grounds on which the Owner based the notice of the deficiency, and the result of the notice.
- J. Has your company been assessed liquidated damages or had payment withheld by any Owner during the term of a contract for similar services? YES \_\_\_\_ NO \_\_\_\_\_. If so, as to each assessment of liquidated damages or payment withheld, state the name of the Owner, the date of the assessment/withheld payment, the title and number of the contract, and the grounds on which the Owner based the assessment of liquidated damages/payment withheld.
- K. Is your company currently a party in any litigation against any Owner pertaining to any contract for services project, or has your company been a party to such litigation? YES \_\_\_\_ NO \_\_\_\_\_. If so, as to each such litigation, state the name of the Owner, case number, the court and jurisdiction in which said litigation is pending or was brought, the nature of the litigation, the amount at issue in the litigation, the present status of such litigation, the date of resolution of such litigation if resolved, and the amount and method by which such litigation was resolved, if resolved.





**This Page Has Been Left Blank Intentionally**

**AGREEMENT FOR GENERAL SERVICES  
WITH THE PLEASANT VALLEY RECREATION AND PARK DISTRICT (“DISTRICT”)**

Project Name/Description (“**Project**”): Click or tap here to enter text.

Contractor Name (“**Contractor**”): Click or tap here to enter text.

Contractor Business Type: Choose an item.

Contractor Address: Click or tap here to enter text.

Contractor Representative Name and Title (“**Contractor Representative**”): Click or tap here to enter text.

Contractor Representative Work Phone and Email: Click or tap here to enter text.

**Termination Date:** Click or tap here to enter text.

Total Not-To-Exceed Contract Amount (“**Contract Sum**”): Click or tap here to enter text.

District Contact (“District Contact”):Click or tap here to enter text.

District Contact Work Phone and Email:Click or tap here to enter text.



## RECITALS

The District desires to contract with a Contractor to provide services as more further set forth herein.

The District circulated a Request for Quotes or Proposals for the above-described services.

Contractor submitted a quote or proposal to District to provide the above-described services.

District Staff has reviewed all the proposals and after considering the demonstrated competence of Contractor, the qualifications of Contractor, and the fairness and reasonableness of Contractor's proposed cost, staff has determined that an agreement to provide the required services should be awarded to Contractor.

## AGREEMENT

THIS AGREEMENT FOR SERVICES ("**Agreement**") is made and entered into and effective on the date executed by the District by and between the Pleasant Valley Recreation and Park District ("**District**") and ("**Contractor**"). District and Contractor may be referred to individually as "**Party**" or collectively as "**Parties**." In consideration of the mutual promises and covenants made by the Parties and contained herein and other consideration, the value and adequacy of which are hereby acknowledged, the Parties agree as follows:

### **ARTICLE 1. SERVICES OF CONTRACTOR**

- 1.1 Scope of Services.** In compliance with all terms and conditions of this Agreement, Contractor shall provide those services specified in the "**Scope of Services**" attached hereto as Exhibit A and incorporated herein by this reference, which may be referred to herein as the "**services**" or "**work**" hereunder. As a material inducement to District entering into this Agreement, Contractor represents and warrants: a) it has the qualifications, experience, and facilities necessary to properly perform the Services required under this Agreement b) all services set forth in the Scope of Services will be performed in a competent and satisfactory manner; c) all materials used for services will be both of good quality as well as fit for the purpose intended; and, d) Contractor shall follow the highest professional standards and practices in performing the services required hereunder.
- 1.2 Contractor's Proposal.** The Scope of Services shall include the scope of services or work included in Contractor's proposal or bid, which shall be incorporated herein by this reference as though fully set forth herein. In the event of any inconsistency between the terms of such proposal or bid, and this Agreement, the terms of this Agreement shall govern. No other terms and conditions from Contractor's proposal or bid, other than description of scope of services or work, shall apply to this Agreement, unless specifically agreed to by District in writing.
- 1.3 Compliance with Law.** All services rendered hereunder shall be provided in accordance with all ordinances, resolutions, statutes, rules and regulations of District and any federal, State or local governmental agency having jurisdiction in effect at

the time services are rendered. District, and its officers, employees and agents, shall not be liable at law or in equity for failure of Contractor to comply with this Section.

- 1.4 Licenses, Permits, Fees and Assessments.** Contractor shall obtain at its sole cost and expense such licenses, permits and approvals as may be required by law for the performance of the services required by this Agreement. Contractor shall have the sole obligation to pay for any fees, assessments and taxes, plus applicable penalties and interest, which may be imposed by law and arise from or are necessary for Contractor's performance of the services required by this Agreement, and shall indemnify, defend and hold harmless District against any such fees, assessments, taxes, penalties or interest levied, assessed or imposed against District hereunder.
- 1.5 Familiarity with Work.** By executing this Agreement, Contractor represents and warrants Contractor: a) has thoroughly investigated and considered services to be performed, b) has carefully considered how services should be performed, and c) fully understands the facilities, difficulties and restrictions attending performance of services under this Agreement.
- 1.6 Software and Computer Services.** If the Scope of Services includes the provision and/or installation of any software, computer system, or other computer technology, Contractor represents and warrants that it is familiar with and/or has inspected District's current infrastructure, equipment, computer system and software and that the software, computer system, or other computer technology provided and/or installed by Contractor under this Agreement is compatible, and shall be fully functional, with such infrastructure, equipment, computer system and software of District. Contractor acknowledges that District is relying on this representation by Contractor as a material consideration in entering into this Agreement.
- 1.7 Prevailing Wages.** If services include any "public work" or "maintenance work," as those terms are defined in California Labor Code section 1720 *et seq.* and California Code of Regulations, Title 8, section 16000 *et seq.*, and if the total compensation is \$1,000 or more, Contractor shall pay prevailing wages for such work and comply with the requirements in California Labor Code section 1770 *et seq.* and 1810 *et seq.*, and all other applicable laws.

## **ARTICLE 2. COMPENSATION AND METHOD OF PAYMENT**

- 2.1 Contract Sum.** Subject to any limitations set forth in this Agreement, District agrees to pay Contractor the rates specified in the "Schedule of Compensation" attached hereto as **Exhibit B** and incorporated herein by this reference. The total compensation for all work, including reimbursement for actual expenses, shall not exceed the Contract Sum set forth above. Compensation may include reimbursement, for actual and necessary expenditures, if both are specified in the Schedule of Compensation, as well as approved by District in advance.
- 2.2 Invoices.** Contractor shall submit to District, in a form approved by District, an invoice for services rendered prior to the date of the invoice. By submitting an invoice for payment under this Agreement, Contractor is certifying compliance with all

provisions of this Agreement. Except as provided in Sections 7.3, 7.4 and 7.5, District shall pay Contractor for all expenses stated thereon which are approved by District pursuant to this Agreement within thirty (30) days from the submission of an invoice in an approved form. In the event any charges or expenses are disputed by District, the original invoice shall be returned by District to Contractor for correction and resubmission. Review and payment by District for any invoice provided by Contractor shall not constitute a waiver of any rights or remedies provided herein or any applicable law. Each invoice is to include (unless otherwise specified by District): 1) line items for all personnel describing the work performed, the number of hours worked, and the hourly rate; 2) line items for all materials and equipment properly charged to the Services; 3) line items for all other approved reimbursable expenses claimed, with supporting documentation; and 4) line items for all approved subcontractor labor, supplies, equipment, materials, and travel properly charged to the Services.

### **ARTICLE 3. PERFORMANCE SCHEDULE**

**3.0 Time of Essence.** Time is of the essence in the performance of this Agreement.

**3.1 Term.** The Agreement shall commence upon the Effective Date set forth above and will continue until the Termination Date.

Unless earlier terminated in accordance with Article 7 of this Agreement, this Agreement shall continue in full force and effect until completion of any ongoing services, which shall be no later than the Termination Date set forth above. Notwithstanding the foregoing, the Indemnification and Insurance provisions set forth in Article 5 shall survive the termination of this Agreement.

**3.2 Schedule of Performance.** Contractor shall commence the services pursuant to this Agreement upon receipt of a written notice to proceed from District and shall perform all services within the time period(s) established in the "Schedule of Performance" attached hereto as **Exhibit C** and incorporated herein by this reference.

**3.3 Force Majeure.** The time period(s) specified in the Schedule of Performance for performance of the services rendered pursuant to this Agreement shall be extended because of any delays due to unforeseeable causes beyond the control and without the fault or negligence of Contractor, including, but not restricted to, acts of God or of the public enemy, unusually severe weather, fires, earthquakes, floods, epidemics, quarantine restrictions, riots, strikes, freight embargoes, wars, litigation, and/or acts of any governmental agency, including District, if Contractor shall within ten (10) days of the commencement of such delay notify District in writing of the causes of the delay. District shall ascertain the facts and the extent of delay, and extend the time for performing the services for the period of the enforced delay when and if in the judgment of District such delay is justified. District's determination shall be final and conclusive upon the Parties to this Agreement. In no event shall Contractor be entitled to recover damages against District for any delay in the performance of this

Agreement, however caused, Contractor's sole remedy being extension of this Agreement pursuant to this Section.

#### **ARTICLE 4. COORDINATION OF WORK**

- 4.1 Representative of Contractor.** The Contractor Representative is authorized to act on Contractor's behalf with respect to the work or services specified herein and to make all decisions in connection therewith. It is expressly understood that the experience, knowledge, capability and reputation of the representative was a substantial inducement for District to enter into this Agreement. Therefore, the representative shall be responsible during the term of this Agreement for directing all activities of Contractor and devoting sufficient time to personally supervise the services hereunder. For purposes of this Agreement, the representative may not be replaced nor may their responsibilities be substantially reduced by Contractor without the express written approval of District.
- 4.2 Department Contact for District.** The District Contact (or other person designated by the District) shall be the primary person on behalf of District responsible for the administration of the Agreement. It shall be Contractor's responsibility to assure that the District Contact is kept informed of both the progress of the performance of the services as well as any decisions which must be made by District.
- 4.3 Independent Contractor.** Neither District, nor any of its officers, employees or agents, shall have any control over the manner or means by which Contractor, or its officers, employees, agents or subcontractors, perform the services required herein, except as otherwise set forth herein. Contractor shall perform all services required herein as an independent contractor of District and shall remain under only such obligations as are consistent with that role. Contractor shall not at any time or in any manner represent that it, or any of its officers, employees, agents or subcontractors, are officers, employees or agents of District. District shall not in any way or for any purpose become or be deemed to be a partner of Contractor in its business or otherwise or a joint venturer or a member of any joint enterprise with Contractor. Contractor shall not incur or have the power to incur any debt, obligation or liability whatever against District, or bind District in any manner. Contractor represents and warrants that the personnel used to provide services to District pursuant to this Agreement shall at all times be under Contractor's exclusive control and direction. No District employee benefits shall be available to Contractor, its officers, employees, agents or subcontractors, in connection with the performance of this Agreement. District shall not be liable for compensation or indemnification to Contractor, its officers, employees, agents or subcontractors, for injury or sickness arising out of performing services hereunder.
- 4.4 Subcontracting or Assignment.** The experience, knowledge, capability and reputation of Contractor, its principals and employees were a substantial inducement for District to enter into this Agreement. Therefore, without express written approval of District, Contractor shall not contract with any other entity to perform in whole or in part services required hereunder without express written approval of District, and neither this Agreement nor any interest herein may be transferred or assigned. No

approved transfer shall release Contractor, or any surety or insured of Contractor, of any liability hereunder without express written consent of District.

## **ARTICLE 5. INSURANCE AND INDEMNIFICATION**

**5.1 Insurance Coverages.** Prior to commencement of any services under this Agreement, and without limiting Contractor's indemnification obligation to District, Contractor shall procure and maintain, at its sole cost and expense, in a form and content satisfactory to District, for the duration of the Agreement, primary policies of insurance of the type and amounts set forth in the "Insurance Requirements" attached hereto as **Exhibit D** and incorporated herein by this reference.

### **5.2 Indemnification.**

(a) **General Obligations.** Contractor agrees, to the full extent permitted by law, to indemnify, defend and hold harmless District and its elected and appointed officers, employees and agents (each an "**Indemnitee**" and collectively, "**Indemnitees**") against, and will hold and save them and each of them harmless from, whether actual or threatened, any and all actions, either judicial, administrative, arbitration or regulatory claims, damages to persons or property, losses, costs, penalties, obligations, errors, omissions or liabilities (herein "**Claims or Liabilities**") that may be asserted or claimed by any person, firm or District arising out of or in connection with the performance of the work, operations or activities provided herein of Contractor, its officers, employees, agents, subcontractors, or invitees, or any individual or District for which Contractor is legally liable (each an "**Indemnitor**" and collectively, "**Indemnitors**"), and in connection therewith: 1) Contractor will defend any action or actions filed or threatened in connection with any such Claims or Liabilities, or at option of Indemnitee(s) will reimburse and pay for all costs and expenses, including legal costs and attorneys' fees, incurred by Indemnitee(s) in connection therewith; and, 2) Contractor will promptly pay any judgment rendered against Indemnitee(s) for any such Claims or Liabilities, and will save and hold Indemnitee(s) harmless therefrom.

The indemnity obligation herein shall be binding on successors, assigns and heirs of Contractor and shall survive termination of this Agreement. Contractor shall incorporate similar indemnity agreements as provided herein with its subcontractors, and if Contractor fails to do so Contractor shall be fully responsible to indemnify District hereunder therefor. Failure of District and/or District Parties (collectively "District" for solely this Section 5.2(b)) to monitor compliance with any of the indemnification provisions herein shall not be a waiver hereof. Payment of invoices by District is not a condition precedent to enforcement of the indemnity obligation herein. In the event of any dispute between Contractor and District, as to whether liability arises from the sole negligence or willful misconduct of District, Contractor will be obligated to pay for District's defense until such time as a final judgment has been entered adjudicating District as solely negligent or responsible for willful misconduct. Contractor will not be entitled in the absence of such a determination to any reimbursement of defense costs including but not limited to attorney's fees, expert fees and costs of litigation.

## ARTICLE 6. RECORDS, REPORTS AND RELEASE OF INFORMATION

- 6.1 Records.** Contractor shall keep, and require subcontractors to keep, such ledgers, books of accounts, invoices, vouchers, canceled checks, reports, studies or other documents relating to the disbursements charged to District and services performed hereunder (“**books and records**”) as shall be necessary to perform the services required by this Agreement and enable District to evaluate the performance of such services. Any and all such books and records shall be maintained in accordance with generally accepted accounting principles, shall be complete and detailed, and shall be readily accessible. District shall have full and free access to such books and records at all times during normal business hours of District, including the right to inspect, copy, audit and make records and transcripts. Such books and records shall be maintained for a period of three (3) years following completion of the services hereunder. District shall have access to such books and records in the event any audit is required. Contractor shall fully cooperate with District in providing access to any and all Contractor records and documents if a public records request is made and disclosure is required by law including but not limited to the California Public Records Act.
- 6.2 Ownership of Documents.** All drawings, specifications, maps, designs, photographs, studies, surveys, data, notes, computer files, reports, records, documents and other materials (“**documents and materials**”) prepared by Contractor, its officers, employees, agents and subcontractors in the performance of this Agreement shall be the property of District and shall be delivered to District upon request of District and/or upon the termination of this Agreement, and Contractor shall have no claim for further employment or additional compensation as a result of the exercise by District of its full rights of ownership, use, reuse, or assignment of the documents and materials hereunder. Contractor may retain copies of such documents and materials for its own use. Contractor shall have the right to use the concepts embodied therein. All subcontractors shall provide for assignment to District of any documents and materials prepared by them, and in the event Contractor fails to secure such assignment, Contractor shall indemnify District for all damages resulting therefrom. Moreover, with respect to any Contractor documents and materials that may qualify as “works made for hire” as defined in 17 U.S.C. § 101, such documents and materials are hereby deemed “works made for hire” for District.
- 6.3 Confidentiality and Release of Information.** All information gained or work product produced by Contractor in its performance of this Agreement shall be considered confidential, unless such information is in the public domain or already known to Contractor. Contractor shall not release or disclose any such information or work product to persons or entities other than District without prior written authorization from District. Contractor, its officers, employees, agents or subcontractors, shall not, without prior written authorization from District or unless requested by the District Attorney, voluntarily provide documents, declarations, letters of support, testimony at depositions, response to interrogatories or other information concerning the work performed under this Agreement. Response to a subpoena or court order shall not be considered “voluntary” provided Contractor immediately gives District notice of such court order or subpoena. If Contractor, or

any officer, employee, agent or subcontractor of Contractor, provides any information or work product in violation of this Agreement, then District shall have the right to reimbursement and indemnity from Contractor for any damages, costs and fees, including attorney's fees, caused by or incurred as a result of Contractor's conduct. As concerning, regarding or related to, in any way, this Agreement and the work performed thereunder: a) Contractor shall immediately notify District should Contractor, its officers, employees, agents or subcontractors be served with any summons, complaint, subpoena, notice of deposition, request for documents, interrogatories, request for admissions or other discovery request, court order or subpoena from any party; b) District retains the right, but has no obligation, to represent Contractor or be present at any deposition, hearing or similar proceeding; and, c) Contractor agrees to cooperate fully with District and to provide District with the opportunity to review any response to discovery requests provided by Contractor, however, this right to review any such response does not imply or mean the right by District to control, direct, or rewrite said response.

## **ARTICLE 7. ENFORCEMENT OF AGREEMENT AND TERMINATION**

- 7.1 California Law.** This Agreement shall be interpreted, construed and governed both as to validity and to performance of the Parties in accordance with the laws of the State of California. Legal actions concerning any dispute, claim or matter arising out of or in relation to this Agreement shall be instituted in the Superior Court of the County of Ventura, State of California, or any other appropriate court in such county, and Contractor agrees to submit to the personal jurisdiction of such court in the event of such action.
- 7.2 Suspension, or Termination, Prior to Expiration of Term.** This Section shall govern any termination of this Agreement except as specifically provided in Section 7.4 for termination for cause. District reserves the right to terminate or suspend this Agreement, or any portion hereof, at any time, for any reason, with or without cause, upon ten (10) days' notice to Contractor, except that where termination or suspension is due to the fault of Contractor, the period of notice may be such shorter time as determined by District. Upon receipt of any notice of termination or suspension, Contractor shall immediately cease all services hereunder, unless the notice provides otherwise, or except such as specifically approved by District. Upon submittal of an invoice consistent with Section 2.2, Contractor shall be entitled to compensation for all services rendered prior to the effective date of the notice of termination or suspension and for any services authorized by District thereafter in accordance with the Schedule of Compensation, or such as may be approved by District, except as provided in Section 7.5. In event of termination, or suspension, without cause pursuant to this Section, there is no need to provide opportunity to cure pursuant to Section 7.3.
- 7.3 Default of Contractor and Opportunity to Cure.** In the event that Contractor is in default under the terms of this Agreement, District shall not have any obligation or duty to continue compensating Contractor for any work performed after the date of default. Instead, District may give notice to Contractor of the default and the reasons for the default. The notice shall include the timeframe in which Contractor may cure the default. This timeframe is presumptively ten (10) days, but may be extended, or

reduced, if circumstances warrant, as determined by District. During the period of time that Contractor is in default, District shall hold all invoices and shall, when the default is cured, proceed with payment on the invoices, without liability for interest. In the alternative, District may, in its sole discretion, elect to pay some or all of the outstanding invoices during the period of default. If Contractor does not cure the default by conclusion of noticed timeframe, District may immediately both terminate this Agreement with notice to Contractor as well as pursue the remedy in Section 7.4, without prejudice to any other remedy to which District may be entitled at law, in equity or under this Agreement. Any failure on the part of District to give notice of Contractor's default shall not be deemed to result in a waiver of District's legal rights or any rights arising out of any provision of this Agreement.

**7.4 Termination for Default of Contractor.** If termination is due to the failure of Contractor to fulfill its obligations under this Agreement, District may, after compliance with the provisions of Section 7.3, take over the work and prosecute the same to completion by contract or otherwise, and Contractor shall be liable to the extent that the total cost for completion of the services required hereunder exceeds the compensation herein stipulated (provided that District shall use reasonable efforts to mitigate such damages), and District may withhold any payments to Contractor for the purpose of set-off or partial payment of the amounts owed District therefor.

**7.5 Retention of Funds.** Contractor hereby authorizes District to deduct from any amount payable to Contractor (whether or not arising out of this Agreement) (i) any amounts the payment of which may be in dispute hereunder or which are necessary to compensate District for any losses, costs, liabilities, or damages suffered by District, and (ii) all amounts for which District may be liable to third parties, by reason of Contractor's acts or omissions in performing or failing to perform Contractor's obligation under this Agreement. In the event that any claim is made by a third party, the amount or validity of which is disputed by Contractor, or any indebtedness shall exist which shall appear to be the basis for a claim of lien, District may withhold from any payment due, without liability for interest because of such withholding, an amount sufficient to cover such claim. The failure of District to exercise such right to deduct or to withhold shall not, however, affect the obligations of Contractor to insure, indemnify, and protect District as elsewhere provided herein.

**7.6 Waiver.** Waiver by any Party to this Agreement of any term, condition, or covenant of this Agreement shall not constitute a waiver of any other term, condition, or covenant. Waiver by any Party of any breach of the provisions of this Agreement shall not constitute a waiver of any other provision or a waiver of any subsequent breach or violation of any provision of this Agreement. Acceptance by District of any work or services by Contractor shall not constitute a waiver of any of the provisions of this Agreement. No delay or omission in the exercise of any right or remedy by a non-defaulting Party on any default shall impair such right or remedy or be construed as a waiver. Any waiver by either Party of any default must be in writing and shall not be a waiver of any other default concerning the same or any other provision of this Agreement. Contractor acknowledges and agrees that any actual or alleged failure on the part of District to inform Contractor of non-compliance with any requirement of this Agreement imposes no additional obligations on District nor does it waive any



rights hereunder. Payment to Contractor for work performed pursuant to this Agreement shall not be deemed to waive any defects in work performed by Contractor.

- 7.7 Rights and Remedies are Cumulative.** Except with respect to rights and remedies expressly declared to be exclusive in this Agreement, the rights and remedies of the Parties are cumulative and the exercise by either Party of one or more of such rights or remedies shall not preclude the exercise by it, at the same or different times, of any other rights or remedies for the same default or any other default by the other Party.
- 7.8 Legal Action.** In addition to any other rights or remedies, either Party may take legal action, in law or in equity, to cure, correct or remedy any default, to recover damages for any default, to compel specific performance of this Agreement, to obtain declaratory or injunctive relief, or to obtain any other remedy consistent with the purposes of this Agreement. Notwithstanding any contrary provision herein, Contractor shall file a statutory claim pursuant to Government Code sections 905 *et seq.* and 910 *et seq.*, in order to pursue a legal action under this Agreement.
- 7.9 Attorneys' Fees.** If either Party to this Agreement is required to initiate or defend or made a party to any action or proceeding in any way connected with this Agreement, the prevailing party in such action or proceeding, in addition to any other relief which may be granted, whether legal or equitable, shall be entitled to reasonable attorneys' fees. Attorneys' fees shall include attorneys' fees on any appeal, and a Party entitled to attorneys' fees shall be entitled to all other reasonable costs for investigating such action, Contractors' fees, taking depositions and discovery and all other necessary costs the court allows which are incurred in such litigation. Such fees and costs shall be enforceable whether or not such action is prosecuted to judgment.

## **ARTICLE 8. INDIVIDUAL LIABILITY, CONFLICTS AND NON-DISCRIMINATION**

- 8.1 Non-liability of District Officers and Employees.** No officer or employee of District shall be personally liable to Contractor, or any successor in interest, in the event of any default or breach by District or for any amount which may become due to Contractor or to its successor, or for breach of any obligation of the terms of this Agreement.
- 8.2 Conflict of Interest.** Contractor covenants that neither it, nor any officer or principal of its firm, has or shall acquire any interest, directly or indirectly, which would conflict in any manner with the interests of District or which would in any way hinder Contractor's performance of services under this Agreement. Contractor further covenants that in the performance of this Agreement, no person having any such interest shall be employed by it as an officer, employee, agent or subcontractor without the express written consent of District. Contractor agrees to at all times avoid conflicts of interest or the appearance of any conflicts of interest with the interests of District in the performance of this Agreement. District, in its sole discretion, shall determine the existence of a conflict of interest and may terminate this Agreement in the event such a conflict of interest exists upon sending Contractor written notice describing the conflict. No officer or employee of District shall have any financial

interest, direct or indirect, in this Agreement nor shall any such officer or employee participate in any decision relating to this Agreement which affects their financial interest or the financial interest of any corporation, partnership or association in which they are, directly or indirectly, interested, in violation of any State statute or regulation. Contractor warrants that it has not paid or given and will not pay or give any third party any money or other consideration for obtaining this Agreement.

- 8.3 Covenant Against Discrimination.** Contractor covenants that, by and for itself, its heirs, executors, assigns, and all persons claiming under or through them, that there shall be no discrimination against or segregation of, any person or group of persons on account of race, color, creed, religion, sex, gender, sexual orientation, marital status, national origin, ancestry or other protected class in the performance of this Agreement. Contractor shall take affirmative action to insure that applicants are employed and that employees are treated during employment without regard to their race, color, creed, religion, sex, gender, sexual orientation, marital status, national origin, ancestry or other protected class.

## **ARTICLE 9. MISCELLANEOUS PROVISIONS**

- 9.1 Notices.** Any notice or other communication either Party desires or is required to give to the other Party or any other person in regards to this Agreement must be in writing and may be given either by (i) personal service, (ii) delivery by a reputable document delivery service, such as but not limited to, Federal Express, which provides a receipt showing date and time of delivery, or (iii) mailing in the United States Mail, certified mail, postage prepaid, return receipt requested, in the case of District addressed to Pleasant Valley Recreation and Park District, 1605 Burnely Street, Camarillo, California 93010, and in the case of Contractor, to the person(s) at the address designated on the cover page of this Agreement. Either Party may change its address by notifying the other Party of the change of address in writing. Notice shall be deemed communicated at the time personally delivered or in seventy-two (72) hours from the time of mailing if mailed as provided in this Section.
- 9.2 Interpretation.** The terms of this Agreement shall be construed in accordance with the meaning of the language used and shall not be construed for or against either Party by reason of the authorship of this Agreement, headings used, or any other rule of construction which might otherwise apply.
- 9.3 Counterparts.** This Agreement may be executed in counterparts, each of which shall be deemed an original, and such counterparts shall constitute one and the same instrument.
- 9.4 Integration; Amendment.** This Agreement including the attachments hereto is the entire, complete and exclusive expression of the understanding of the Parties as to the Agreement. It is understood that there are no oral agreements between the Parties hereto affecting this Agreement, and this Agreement supersedes and cancels any and all prior and contemporaneous negotiations, arrangements, agreements and understandings, if any, between the Parties, concerning this Agreement, and none shall be used to interpret this Agreement. No amendment to or modification of this

Agreement shall be valid unless made in writing and approved by Contractor and by District.

- 9.5 Severability.** Should a portion of this Agreement be declared invalid or unenforceable by a judgment or decree of a court of competent jurisdiction, such invalidity or unenforceability shall not affect any of the remaining portions of this Agreement which are hereby declared as severable and shall be interpreted to carry out the intent of the Parties unless the invalid provision is so material that its invalidity deprives either Party of the basic benefit of their bargain or renders this Agreement meaningless.
- 9.6 No Undue Influence.** Contractor declares and warrants that no undue influence or pressure was used against or in concert with any officer or employee of District in connection with the award, terms or implementation of this Agreement, including any method of coercion, confidential financial arrangement, or financial inducement. No officer or employee of District has or will receive compensation, directly or indirectly, from Contractor, or from any officer, employee or agent of Contractor, in connection with the award of this Agreement or any work to be conducted as a result of this Agreement. Violation of this Section shall be a material breach of this Agreement entitling District to remedies in Section 7.4 and any and all remedies at law or equity.
- 9.7 Corporate Authority.** The persons executing this Agreement on behalf of the Parties hereto warrant that (i) such Party is duly organized and existing, (ii) they are duly authorized to execute and deliver this Agreement on behalf of said Party, (iii) by so executing this Agreement, such Party is formally bound to the provisions of this Agreement, and (iv) entering into this Agreement does not violate any provision of any other agreement to which said Party is bound. This Agreement shall be binding upon the heirs, executors, administrators, successors and assigns of the Parties.

**IN WITNESS WHEREOF**, the Parties hereto have executed this Agreement on the date and year first-above written.

**DISTRICT:**

Pleasant Valley Recreation and Park District

By: \_\_\_\_\_

Mary Otten, General Manager

Date:

**CONTRACTOR:**

By: \_\_\_\_\_

Name: Click or tap here to enter text.

Title: Click or tap here to enter text.

Date:

By: \_\_\_\_\_

Name: Click or tap here to enter text.

Title: Click or tap here to enter text.

Date:

**CONTRACTOR:**

Two corporate officer signatures required when Contractor is a corporation, with one signature required from each of the following groups: 1) Chairperson of the Board, President or any Vice President; and 2) Secretary, any Assistant Secretary, Chief Financial Officer or any Assistant Treasurer. (Cal. Corp. Code § 313.) Appropriate attestations shall be included as may be required by the bylaws, articles of incorporation or other rules or regulations applicable to Contractor's business.

**EXHIBIT "A"**

**SCOPE OF SERVICES**

**Contractor will perform the following Services:**

**EXHIBIT "B"**

**SCHEDULE OF COMPENSATION**

- I. District will compensate Contractor for the Services performed upon submission of a valid invoice. Each invoice is to include**
- A.** Line items for all personnel describing the work performed, the number of hours worked, and the hourly rate.
  - B.** Line items for all materials and equipment properly charged to the Services.
  - C.** Line items for all other approved reimbursable expenses claimed, with supporting documentation.
  - D.** Line items for all approved subcontractor labor, supplies, equipment, materials, and travel properly charged to the Services.
- II. The total compensation for all Services shall not exceed the Contract Sum as provided in the Cover Page of this Agreement.**
- III. Contractor's billing rates for Services are attached as Exhibit B-1.** District will pay Contractor for hourly work completed, billed in increments of six minutes (0.1 hours), not to exceed the Contract Sum. The District may reimburse the Contractor for reasonable out-of-pocket expenses related to performing services on behalf of the District that are approved in advance in writing by the District such as mileage, copies, binding costs, postage, parking, travel, and lodging expenses as part of the not to exceed Contract Sum. To receive reimbursements, the Contractor must provide the District with a receipt and a description of the expense incurred along with the invoice. No mark up on expenses may be added.

**EXHIBIT "C"**

**SCHEDULE OF PERFORMANCE**

- I. Contractor shall deliver the following tangible work products to the District by the following dates:**

Click or tap here to enter text.

- II. The District Contact may approve extensions for performance of the Services in accordance with Section 3.2.**

## EXHIBIT D

### INSURANCE REQUIREMENTS

Pleasant Valley Recreation and Park District (PVRPD) requires evidence of insurance coverage documents, for the duration of any agreement term, a minimum of thirty (30) days prior to an agreement effective date or event, if specified.

The following is required for all Certificates of Insurance and Additional Insured Endorsements.

- Certificate of Insurance (COI) – Coverage shall be primary and non-contributory and at least as broad as and include or state the following:
- Commercial General Liability (CGL): Insurance Services Office Form CG 00 01 covering CGL on an “occurrence” basis, including products and completed operations, property damage, bodily injury, and personal & advertising injury with limits no less than \$2,000,000 per occurrence, \$4,000,000 aggregate. If a general aggregate limit applies, either the general aggregate limit shall apply separately to this project/location (ISO CG 25 03 or 25 04) or the general aggregate limit shall be twice the required occurrence limit.
- Automobile Liability: ISO Form Number CA 00 01 covering any auto (Code 1), or if Contractor has no owned autos, hired, (Code 8) and non-owned autos (Code 9), with limit no less than \$1,000,000 per accident for bodily injury and property damage.
- Workers’ Compensation: as required by the State of California, with Statutory Limits, and Employer’s Liability Insurance with limit of no less than \$1,000,000 per accident for bodily injury or disease. Waiver of Subrogation Endorsement required.
- Umbrella Liability/Excess Liability - Policies shall be provided on a true “following form” or broader coverage basis, with coverage at least as broad as provided on the underlying Commercial General Liability insurance. No insurance policies maintained by the Additional Insureds, whether primary or excess, and which also apply to a loss covered hereunder, shall be called upon to contribute to a loss until the Contractor’s primary and excess liability policies are exhausted.
- Insured: Must match entity named within the agreement.
- Insurer’s Affording Coverage: Must have an assigned policyholders’ Rating of A- (or higher) and Financial Size Category Class VII (or larger) in accordance with the latest edition of Best’s Key Rating Guide, unless otherwise approved by the District.
- Policy Effective/Expiration Date: Must cover dates of service or event.
- Description of Operations: Must read "Pleasant Valley Recreation and Park District, its elected and appointed officials, agents, volunteers, and employees are listed as an Additional Insured." Include address, date, and name/type of event or description of project.



- Certificate Holder: Must read “Pleasant Valley Recreation and Park District 1605 Burnley Street, Camarillo, CA 93010” (No abbreviations accepted)
- Additional Insured Endorsements (AIE) – Endorsements must include or state the following:
- Policy Number: Must match policy numbers on COI.
- Additional Insured – Designated Person or Organization: Must state “This endorsement changes the policy.”
- Schedule – Name Of Additional Insured Person(s) or Organization(s): Must read ““Pleasant Valley Recreation and Park District, its elected and appointed officials, agents, volunteers, and employees.”
- Primary and Noncontributory – Endorsement must be provided.
- Waiver of Subrogation – Endorsement must be provided.
- Notice of Cancellation – A cancellation clause shall state the following: “Should any of the above described policies be cancelled before the expiration date thereof, the issuing company will mail 30 days written notice to the certificate holder named.”

District reserves the right to modify these requirements, including limits, based on the nature of the risk, prior experience, insurer, coverage, or other special circumstances. Coverage limits listed above are to be considered minimum coverage, District reserves the right to require higher limits and additional coverages at its discretion. If the Contractor maintains broader coverage and/or higher limits than the minimums shown above, District requires and shall be entitled to the broader coverage and/or the higher limits maintained by the contractor. Any available insurance proceeds in excess of the specified minimum limits of insurance and coverage shall be available to District.

**PLEASANT VALLEY RECREATION AND PARK DISTRICT  
STAFF REPORT / AGENDA REPORT**

**TO: BOARD OF DIRECTORS**

**FROM: MARY OTTEN, GENERAL MANAGER**  
**By: Justin Kiraly, Administrative Services Manager**

**DATE: March 5, 2025**

**SUBJECT: CONSIDERATION AND APPROVAL OF  
ESTABLISHING THE GENERAL MANAGER,  
ADMINISTRATIVE SERVICES MANAGER, AND PARK  
SERVICES MANAGER POSITIONS AS AUTHORIZED  
SIGNERS FOR CAL OES FOR A PERIOD OF 3 YEARS**

**BACKGROUND**

The California Governor’s Office of Emergency Services (Cal OES) is the agency responsible for collecting and distributing federal financial assistance for disaster assistance, including but not limited to Federally Declared Disasters and the Hazard Mitigation Grant Program. The Pleasant Valley Recreation and Park District does not currently have a valid Designation of Applicant's Agent Resolution for Non-State Agencies (Form 130) on file.

**ANALYSIS**

The District has previously received federal emergency funds for disaster assistance and now needs to submit an updated Form 130 with Cal OES. Keeping this form current is essential to expedite access to potential funding in the event of future disasters. Due to the location of many District parks and facilities, maintaining an active, unexpired form on file is a best practice to streamline the funding process when needed.

**FISCAL IMPACT**

There is no fiscal impact.

**RECOMMENDATION**

It is recommended that the Board approve and sign the Cal OES Form 130 to designate the General Manager, Administrative Services Manager, and Park Services Manager positions as authorized signers for a period of 3 years.

**ATTACHMENT**

- 1) Designation of Applicant's Agent Resolution for Non-State Agencies – Cal OES Form 130 (4 pages)



Cal OES ID No: \_\_\_\_\_

**DESIGNATION OF APPLICANT'S AGENT RESOLUTION FOR NON-STATE AGENCIES**

BE IT RESOLVED BY THE \_\_\_\_\_ OF THE \_\_\_\_\_  
 (Governing Body) (Name of Applicant)

THAT \_\_\_\_\_, OR  
 (Title of Authorized Agent)

\_\_\_\_\_, OR  
 (Title of Authorized Agent)

\_\_\_\_\_  
 (Title of Authorized Agent)

is hereby authorized to execute for and on behalf of the \_\_\_\_\_,  
 (Name of Applicant)

a public entity established under the laws of the State of California, this application and to file it with the California Governor's Office of Emergency Services for the purpose of obtaining federal financial assistance for any existing or future grant program, including, but not limited to any of the following:

- **Federally declared Disaster (DR), Fire Mitigation Assistance Grant (FMAG), California State Only Disaster (CDAA), Immediate Services Program (ISP), Hazard Mitigation Grant Program (HMGP), Building Resilient Infrastructure and Communities (BRIC), Legislative Pre-Disaster Mitigation Program (LPDM)**, under
- Public Law 93-288 as amended by the Robert T. Stafford Disaster Relief and Emergency Assistance Act of 1988, and/or state financial assistance under the California Disaster Assistance Act.
- **Flood Mitigation Assistance Program (FMA)**, under Section 1366 of the National Flood Insurance Act of 1968.
- **National Earthquake Hazards Reduction Program (NEHRP)** 42 U.S. Code 7704 (b) ((2) (A) (ix) and 42 U.S. Code 7704 (b) (2) (B) National Earthquake Hazards Reduction Program, and also The Consolidated Appropriations Act, 2018, Div. F, Department of Homeland Security Appropriations Act, 2018, Pub. L. No. 115-141
- **California Early Earthquake Warning (CEEW)** under CA Gov Code – Gov, Title 2, Div. 1, Chapter 7, Article 5, Sections 8587.8, 8587.11, 8587.12

That the \_\_\_\_\_, a public entity established under the  
 (Name of Applicant)

laws of the State of California, hereby authorizes its agent(s) to provide to the Governor's Office of Emergency Services for all matters pertaining to such state disaster assistance the assurances and agreements required.



**Please check the appropriate box below**

- This is a universal resolution and is effective for all open and future disasters/grants declared up to three (3) years following the date of approval.
- This is a disaster/grant specific resolution and is effective for only disaster/grant number(s): \_\_\_\_\_

Passed and approved this \_\_\_ day of \_\_\_\_\_, 20\_\_

\_\_\_\_\_  
 (Name and Title of Governing Body Representative)

\_\_\_\_\_  
 (Name and Title of Governing Body Representative)

\_\_\_\_\_  
 (Name and Title of Governing Body Representative)

**CERTIFICATION**

I, \_\_\_\_\_, duly appointed and \_\_\_\_\_ of  
 (Name) (Title)

\_\_\_\_\_, do hereby certify that the above is a true and  
 (Name of Applicant)

correct copy of a resolution passed and approved by the \_\_\_\_\_  
 (Governing Body)

of the \_\_\_\_\_ on the \_\_\_\_\_ day of \_\_\_\_\_, 20\_\_.  
 (Name of Applicant)

\_\_\_\_\_  
 (Signature)

\_\_\_\_\_  
 (Title)



### Cal OES Form 130 Instructions

**A Designation of Applicant's Agent Resolution for Non-State Agencies is required of all Applicants to be eligible to receive funding. A new resolution must be submitted if a previously submitted resolution is older than three (3) years from the last date of approval, is invalid, or has not been submitted.**

When completing the Cal OES Form 130, Applicants should fill in the blanks on pages 1 and 2. The blanks are to be filled in as follows:

#### **Resolution Section:**

**Governing Body:** This is the group responsible for appointing and approving the Authorized Agents.

Examples include: Board of Directors, City Council, Board of Supervisors, Board of Education, etc.

**Name of Applicant:** The public entity established under the laws of the State of California.

Examples include: School District, Office of Education, City, County or Non-profit agency that has applied for the grant, such as: City of San Diego, Sacramento County, Burbank Unified School District, Napa County Office of Education, University Southern California.

**Authorized Agent:** These are the individuals that are authorized by the Governing Body to engage with the Federal Emergency Management Agency and the California Governor's Office of Emergency Services regarding grants for which they have applied. There are two ways of completing this section:

1. **Titles Only:** The titles of the Authorized Agents should be entered here, not their names. This allows the document to remain valid if an Authorized Agent leaves the position and is replaced by another individual. If "Titles Only" is the chosen method, this document must be accompanied by either a cover letter naming the Authorized Agents by name and title, or the Cal OES AA Names document. The supporting document can be completed by any authorized person within the Agency (e.g., administrative assistant, the Authorized Agent, secretary to the Director). It does not require the Governing Body's signature.
2. **Names and Titles:** If the Governing Body so chooses, the names **and** titles of the Authorized Agents would be listed. A new Cal OES Form 130 will be required if any of the Authorized Agents are replaced, leave the position listed on the document, or their title changes.



**Checking Universal or Disaster-Specific Box:** A Universal resolution is effective for all past disasters and for those declared up to three (3) years following the date of approval. Upon expiration it is no longer effective for new disasters, but it remains in effect for disasters declared prior to expiration. It remains effective until the disaster goes through closeout unless it is superseded by a newer resolution.

**Governing Body Representative:** These are the names and titles of the approving Board Members.

Examples include: Chairman of the Board, Director, Superintendent, etc. The names and titles **cannot** be one of the designated Authorized Agents. A minimum of three (3) approving board members must be listed. If less than three are present, meeting minutes must be attached in order to verify a quorum was met.

**Certification Section:**

**Name and Title:** This is the individual in attendance who recorded the creation and approval of this resolution.

Examples include: City Clerk, Secretary to the Board of Directors, County Clerk, etc. This person **cannot** be one of the designated Authorized Agents or Approving Board Member. If a person holds two positions (such as City Manager and Secretary to the Board) and the City Manager is to be listed as an Authorized Agent, then that person could sign the document as Secretary to the Board (not City Manager) to eliminate "Self-Certification."

**PLEASANT VALLEY RECREATION AND PARK DISTRICT  
STAFF REPORT/AGENDA REPORT**

**TO: BOARD OF DIRECTORS**

**FROM: MARY OTTEN, GENERAL MANAGER**  
**By: Justin Kiraly, Administrative Services Manager**

**DATE: March 5, 2025**

**SUBJECT: CONSIDERATION AND RECEIPT OF THE FY 2023-2024 ANNUAL FINANCIAL REPORT AS PREPARED BY MOSS, LEVY & HARTZHEIM LLP, CPAs**

**BACKGROUND**

Every year the District conducts a financial audit to ensure the effective operation of the District and to make sure the District is following Generally Accepted Accounting Principles (GAAP). The audit improves accountability, ethical and professional practices, and effective risk management; enhances the quality of output; and supports decision-making and performance tracking.

The audited Financial Report for the period ending June 30, 2024, has been completed by Moss, Levy, & Hartzheim, LLP, CPAs with Adam Guise, CPA, and partner serving as the lead contact for the audit.

Staff have been working on the audit since the audit team first engaged with staff remotely in July 2024, followed by an in-person engagement in October 2024. It is the goal of staff to provide the auditors with complete and accurate records and to display their commitment to maintaining the District's financial records.

**ANALYSIS**

The opinion of the auditor reflects that the District's financial statements present fairly, in all material respects, the respective financial position for the year ending June 30, 2024, in conformity with accounting principles generally accepted in the United States of America.

The primary source of funds for the District is property tax revenue. The District received 6.55% in property tax apportionment more than in the prior fiscal year 2022-2023. In addition to property tax revenue increasing year over year, the District has also benefitted from continued interest in rentals and programs. For FY 2023-2024, *Registrations and Other Fees* and *Facility & Other Rental Fees* combined grew by 37.23%. The District also received over \$1.8 million in *Ordinance Fees* for Park Impact Developer Fees, found in Fund 40. Overall, the District received 11.78% less revenue in FY 2023-2024 versus last fiscal year; However, removing the two one-time contributions from FY 2022-2023 and the *Ordinance Fees* from FY 2023-2024, ongoing revenue was up 6.87%.

Overall District expenditures increased by 0.33% over the prior fiscal year. Adjusting for *Debt Service* and *Capital Outlay*, \$202,276 of which was Quimby funds, expenditures for cost of operations increased by 7.56%. The District continues to promote and offer expanded programs and classes. These increases in expenditure contribute to the increases in revenue the District received this year.

An item that continues to put strain on the District's financials is the California Public Employee's Retirement System (CalPERS) unfunded liability. While the District has been able to develop a balanced budget each year, CalPERS unfunded liability continues to increase and will continue to cause a strain on the General Fund budget. While the District has been able to make additional payments in the last 2 years to relieve some of the pressure, a significant downturn in the economy would significantly affect the unfunded liability.

### **FISCAL IMPACT**

There is no anticipated fiscal impact to the District from this recommendation.

### **STRATEGIC PLAN COMPLIANCE**

Meets 2021 Strategic Plan Goal

- 1.0: To ensure the short and long-term fiscal health of the District.

### **RECOMMENDATION**

It is recommended that the Board receive and file the Annual Financial Report for Fiscal Year 2023-2024 as prepared by Moss, Levy & Hartzheim, LLP, CPAs.

### **ATTACHMENTS**

- 1) Audit Report (60 pages)



**PLEASANT VALLEY  
RECREATION AND PARK DISTRICT**

FINANCIAL STATEMENTS  
JUNE 30, 2024



**PLEASANT VALLEY RECREATION AND PARK DISTRICT**  
**TABLE OF CONTENTS**  
 June 30, 2024

---

**FINANCIAL SECTION**

Independent Auditors' Report ..... 1  
 Management's Discussion and Analysis ..... 3

**BASIC FINANCIAL STATEMENTS**

Government-wide Financial Statements:  
     Statement of Net Position ..... 10  
     Statement of Activities ..... 11  
 Fund Financial Statements:  
     Balance Sheet – Governmental Funds ..... 12  
     Reconciliation of the Governmental Funds Balance Sheet to  
         the Statement of Net Position ..... 13  
     Statement of Revenues, Expenditures, and Changes in Fund Balances –  
         Governmental Funds ..... 14  
     Reconciliation of the Governmental Funds Statement of Revenues, Expenditures,  
         and Changes in Fund Balances to the Statement of Activities ..... 15  
     Statement of Fiduciary Net Position – Fiduciary Fund ..... 16  
     Statement of Changes in Fiduciary Net Position – Fiduciary Fund ..... 17  
 Notes to Basic Financial Statements ..... 18

**REQUIRED SUPPLEMENTARY INFORMATION**

Schedule of Revenues, Expenditures, and Changes in Fund Balance –  
     Budget and Actual – General Fund ..... 39  
 Schedule of Revenues, Expenditures, and Changes in Fund Balance –  
     Budget and Actual – Special Revenue Fund – Assessment District Fund ..... 40  
 Schedule of Revenues, Expenditures, and Changes in Fund Balance –  
     Budget and Actual – Special Revenue Fund – Quimby Fund ..... 41  
 Schedule of Changes in the OPEB Liability and Related Ratios ..... 42  
 Schedule of OPEB Contributions ..... 43  
 Schedule of Proportionate Share of Net Pension Liability ..... 44  
 Schedule of Pension Contributions ..... 45

**SUPPLEMENTARY INFORMATION**

Combining Balance Sheet – Nonmajor Governmental Funds ..... 47  
 Combining Statement of Revenues, Expenditures, and Changes in Fund  
     Balances – Nonmajor Governmental Funds ..... 48



**FINANCIAL SECTION**



## INDEPENDENT AUDITORS' REPORT

Board of Directors  
Pleasant Valley Recreation and Park District  
Camarillo, California

### Opinions

We have audited the accompanying financial statements of the governmental activities, each major fund, and the aggregate remaining fund information of the Pleasant Valley Recreation and Park District, as of and for the fiscal year ended June 30, 2024, and the related notes to the financial statements, which collectively comprise the Pleasant Valley Recreation and Park District's basic financial statements as listed in the table of contents.

In our opinion, the financial statements referred to above present fairly, in all material respects, the respective financial position of the governmental activities, each major fund, and the aggregate remaining fund information of the Pleasant Valley Recreation and Park District, as of June 30, 2024, and the respective changes in financial position for the fiscal year then ended in accordance with accounting principles generally accepted in the United States of America.

### Basis for Opinions

We conducted our audit in accordance with auditing standards generally accepted in the United States of America and the standards applicable to financial audits contained in *Government Auditing Standards*, issued by the Comptroller General of the United States. Our responsibilities under those standards are further described in the Auditor's Responsibilities for the Audit of the Financial Statements section of our report. We are required to be independent of the Pleasant Valley Recreation and Park District and to meet our other ethical responsibilities, in accordance with the relevant ethical requirements relating to our audit. We believe that the audit evidence we have obtained is sufficient and appropriate to provide a basis for our audit opinions.

### Responsibilities of Management for the Financial Statements

Management is responsible for the preparation and fair presentation of the financial statements in accordance with accounting principles generally accepted in the United States of America, and for the design, implementation, and maintenance of internal control relevant to the preparation and fair presentation of financial statements that are free from material misstatement, whether due to fraud or error.

In preparing the financial statements, management is required to evaluate whether there are conditions or events, considered in the aggregate, that raise substantial doubt about the Pleasant Valley Recreation and Park District's ability to continue as a going concern for twelve months beyond the financial statement date, including any currently known information that may raise substantial doubt shortly thereafter.

### Auditors' Responsibilities for the Audit of the Financial Statements

Our objectives are to obtain reasonable assurance about whether the financial statements as a whole are free from material misstatement, whether due to fraud or error, and to issue an auditor's report that includes our opinions. Reasonable assurance is a high level of assurance but is not absolute assurance and therefore is not a guarantee that an audit conducted in accordance with generally accepted auditing standards and *Government Auditing Standards* will always detect a material misstatement when it exists. The risk of not detecting a material misstatement resulting from fraud is higher than for one resulting from error, as fraud may involve collusion, forgery, intentional omissions, misrepresentations, or the override of internal control. Misstatements are considered material if there is a substantial likelihood that, individually or in the aggregate, they would influence the judgment made by a reasonable user based on the financial statements.

In performing an audit in accordance with generally accepted auditing standards and *Government Auditing Standards*, we:

- Exercise professional judgment and maintain professional skepticism throughout the audit.
- Identify and assess the risks of material misstatement of the financial statements, whether due to fraud or error, and design and perform audit procedures responsive to those risks. Such procedures include examining, on a test basis, evidence regarding the amounts and disclosures in the financial statements.

- Obtain an understanding of internal control relevant to the audit in order to design audit procedures that are appropriate in the circumstances, but not for the purpose of expressing an opinion on the effectiveness of the Pleasant Valley Recreation and Park District's internal control. Accordingly, no such opinion is expressed.
- Evaluate the appropriateness of accounting policies used and the reasonableness of significant accounting estimates made by management, as well as evaluate the overall presentation of the financial statements.
- Conclude whether, in our judgment, there are conditions or events, considered in the aggregate, that raise substantial doubt about the Pleasant Valley Recreation and Park District's ability to continue as a going concern for a reasonable period of time.

We are required to communicate with those charged with governance regarding, among other matters, the planned scope and timing of the audit, significant audit findings, and certain internal control-related matters that we identified during the audit.

### **Required Supplementary Information**

Accounting principles generally accepted in the United States of America require that the management's discussion and analysis, the budgetary comparison information for the General Fund and all major special revenue funds, the schedule of changes in OPEB liability and related ratios, the schedule of OPEB contributions, the schedule of proportionate share of pension liability, and the schedule of pension contributions be presented to supplement the basic financial statements. Such information, although not a part of the basic financial statements, is required by the Governmental Accounting Standards Board, who considers it to be an essential part of financial reporting for placing the basic financial statements in an appropriate operational, economic, or historical context. We have applied certain limited procedures to the required supplementary information in accordance with auditing standards generally accepted in the United States of America, which consisted of inquiries of management about the methods of preparing the information and comparing the information for consistency with management's responses to our inquiries, the basic financial statements, and other knowledge we obtained during our audit of the basic financial statements. We do not express an opinion or provide any assurance on the information because the limited procedures do not provide us with sufficient evidence to express an opinion or provide any assurance.

### **Supplementary Information**

Our audit was performed for the purpose of forming opinions on the financial statements that collectively comprise the Pleasant Valley Recreation and Park District's basic financial statements. The supplementary information listed in the table of contents is presented for purposes of additional analysis and is not a required part of the basic financial statements.

The supplementary information listed in the table of contents is the responsibility of management and was derived from and relates directly to the underlying accounting and other records used to prepare the financial statements. The information has been subjected to the auditing procedures applied in the audit of the financial statements and certain additional procedures, including comparing and reconciling such information directly to the underlying accounting and other records used to prepare the financial statements or to the financial statements themselves, and other additional procedures in accordance with auditing standards generally accepted in the United States of America. In our opinion, the information is fairly stated in all material respects in relation to the financial statements as a whole.

### **Other Reporting Required by Government Auditing Standards**

In accordance with *Government Auditing Standards*, we have also issued our report dated January 7, 2025, on our consideration of the Pleasant Valley Recreation and Park District's internal control over financial reporting and on our tests of its compliance with certain provisions of laws, regulations, contracts, and grant agreements and other matters. The purpose of that report is to describe the scope of our testing of internal control over financial reporting and compliance and the results of that testing, and not to provide an opinion on internal control over financial reporting or on compliance. That report is an integral part of an audit performed in accordance with *Government Auditing Standards* in considering the District's internal control over financial reporting and compliance.

### **Report on Summarized Comparative Information**

We have previously audited the District's basic financial statements as of and for the fiscal year ended June 30, 2023, and we expressed unmodified audit opinions on those audited financial statements in our report dated February 12, 2024. In our opinion, the summarized comparative information presented herein as of and for the fiscal year ended June 30, 2023, is consistent, in all material respects, with the audited financial statements from which it has been derived.

*Moss, Renz & Hartgen LLP*

Santa Maria, California  
January 7, 2025



**PLEASANT VALLEY RECREATION AND PARK DISTRICT**  
**Management's Discussion and Analysis**  
**Fiscal Year Ended June 30, 2024**

This discussion and analysis of the Pleasant Valley Recreation and Park District (PVRPD) financial performance provides an overall review of the PVRPD financial activities for the fiscal year ended June 30, 2024. The intent of this narrative is to provide a complete overview of PVRPD's financial performance. Readers should review this in conjunction with the basic financial statements which follow this section.

**FINANCIAL HIGHLIGHTS**  
**GOVERNMENTAL FUNDS**

- During the fiscal year ending June 30, 2024, PVRPD's government wide net position increased by \$4,662,476 (10.96%), which includes assets, deferred outflows of resources, liabilities, and deferred inflows of resources.
- Total overall revenue decreased by \$2,100,524 (-8.58%), due in part to a year-over-year decrease in the collection of Quimby fees by \$3,779,680, a decrease in Capital grants and contributions of \$1,689,708, an increase in Ordinance Fees, or Park Impact Fees, of \$1,765,248, as well as increases in the Assessment District Fund, property taxes, and investment income. Total General Fund Revenue increased by \$790,031 when adjusting out the \$1,317,275 for the Miracle League of the 805 Ballfield donation received in FY 2023.
- Total expenditures increased by \$38,071. Salaries & Benefits increased by \$123,777 (2.39%) and Materials & Services increased by \$556,152 (14.58%) mainly due to continued increases in prices from inflation. Capital Outlay decreased by \$510,640 (-30.88%) and Debt Service decreased by \$131,218 (-14.89%). Total General Fund expenditures increased by \$846,165 when adjusting out the \$805,686 for the Miracle League of the 805 Ballfield capital expenditures in FY 2023.

**OVERVIEW OF THIS FINANCIAL REPORT**

The Government-wide financial statements are presented on an “economic resources” measurement focus and use an accrual basis of accounting. Accordingly, all the PVRPD's assets and liabilities, including capital assets and long-term liabilities are included in the accompanying Statement of Net Position. The Statement of Net Position includes all the District's investments in resources (Assets) and the obligations to creditors (Liabilities). The Statement of Activities presents changes in net position measuring the success over the past fiscal year and is used to determine credit worthiness.

**Government-wide Financial Statements**

**Statement of Activities and Statement of Net Position**

The Government-wide financial statements are designed to provide readers with a broad overview of the District's finances. The Statement of Net Position and the Statement of Activities answers the question of whether the District's financial position is improving or deteriorating. These statements include all assets, deferred outflow of resources, liabilities, and deferred inflows of resources using the accrual basis of accounting. All changes in net position are reported as soon as the underlying event giving rise to the change occurs, regardless of the timing of related cash flows. These two statements report the District's net position and changes to them. The difference between the assets, deferred outflows of resources, liabilities, and deferred inflows of resources, or net position, can measure the District's financial health.

**Governmental Funds Financial Statements**

**Balance Sheet and Statement of Revenues, Expenditures, and Changes in Fund Balance**

Fund financial statements are designed to report information about groupings or related accounts used to maintain control over resources that have been segregated for specific activities or objectives. The District uses fund accounting, like other state and local governments, to ensure and demonstrate compliance with finance-related legal requirements.

**PLEASANT VALLEY RECREATION AND PARK DISTRICT**  
**Management's Discussion and Analysis**  
**Fiscal Year Ended June 30, 2024**

Governmental funds are used to account for essentially the same functions reported as governmental activities in the government-wide financial statements. However, unlike the government-wide financial statements, governmental funds financial statements focus on the short-term inflow and out-flow of spendable resources, as well as on balance of spendable resources available at the end of the fiscal year. Such information may be useful in evaluating a government's near-term financing requirements.

Both the governmental funds balance sheet and the governmental funds statement of revenues, expenditures, and changes in fund balance provide a reconciliation to facilitate this comparison between governmental funds and governmental activities.

**Notes to Basic Financial Statements**

The notes provide additional information that is essential to fully understanding the data provided in the government-wide and fund financial statements.

**Other Information**

In addition to the basic financial statements and accompanying notes, this report also presents certain required supplemental information concerning the District's budgetary status and funding progress of its retirement plan.

**GOVERNMENT-WIDE FINANCIAL ANALYSIS**

**Statement of Net Position**

Net position may serve, over time, as a useful indicator of a government's financial position. District assets and deferred outflows of resources are above liabilities and deferred inflows of resources by \$47.2 million as of June 30, 2024.

Condensed Statement of Net Position  
June 30,

	<u>2024</u>	<u>2023</u>
<b>Assets:</b>		
Current Assets	\$ 24,492,244	\$ 20,350,166
Noncurrent Assets	3,032,848	3,076,827
Capital Assets (net depreciation)	<u>40,136,627</u>	<u>40,205,029</u>
<b>Total Assets</b>	<b><u>67,661,719</u></b>	<b><u>63,632,022</u></b>
<b>Deferred Outflows of Resources</b>		
Pensions	3,479,887	3,452,801
Other Post Employment Benefits	198,598	222,473
Deferred Charge on Debt Refunding	<u>444,056</u>	<u>474,322</u>
<b>Total Def Outflows of Resources</b>	<b><u>4,122,541</u></b>	<b><u>4,149,596</u></b>
<b>Liabilities:</b>		
Current Liabilities	1,112,806	1,058,781
Long-Term Due in 1 Year	385,702	375,035
Long-Term Due in more than 1 year	<u>18,717,593</u>	<u>19,393,211</u>
<b>Total Liabilities</b>	<b><u>20,216,101</u></b>	<b><u>20,827,027</u></b>

**PLEASANT VALLEY RECREATION AND PARK DISTRICT**  
**Management's Discussion and Analysis**  
**Fiscal Year Ended June 30, 2024**

Deferred Inflows of Resources

Leases	\$ 2,967,966	\$ 3,092,515
Pensions	647,959	827,637
Other Post Employment Benefits	<u>755,676</u>	<u>500,354</u>
<b>Total Def Inflows of Resources</b>	<u>4,371,598</u>	<u>4,420,506</u>

Net Position:

Net Investment in Capital Assets	29,424,077	29,194,891
Net Restricted & Unrestricted	<u>17,772,484</u>	<u>13,339,194</u>
<b>Total Net Position</b>	<u>\$ 47,196,561</u>	<u>\$ 42,534,085</u>

The largest portion of the District’s net position reflects its investment of just over \$40 million in capital assets (land, buildings, improvements, equipment, infrastructure, plus any construction in progress, all net of accumulated depreciation). The District uses these capital assets to provide services to citizens and they are not available for future spending.

The second largest portion is long-term debt, including the debt the District incurred in 2009 for the development of Pleasant Valley Fields Sports Complex formally known as Village at the Park. Certificates of Participation sold for an amount of \$12.6 million with a final maturity date of June 30, 2039. In April 2017, the District refunded the 2009 Certificates of Participation in the amount of \$13.0 million with a final maturity date of November 1, 2045. By refunding the COP the District saved \$644 thousand overall. (For more information on the long-term obligations see Notes 5, 6, and 8 in the Financial Statements).

Total Net Position (assets and deferred outflows of the District minus liabilities and deferred inflows) was \$47,196,561 as of June 30, 2024, which is an increase of \$4,662,476 (10.96%) from the prior fiscal year.

**Statement of Revenues, Expenditures and Changes in Fund Balances**

As shown on the table below, the District's net change in fund balance was an increase of \$4,165,914 in the fiscal year ending June 30, 2024. This increase is due to an overall increase in revenue received during the fiscal year of property tax, special assessments, rentals and registration fees, and other revenues, due in part to increased charges/fees and increased usage of District facilities and programs. Along with an increase in revenue, the District saw an increase in expenditures. This increase in expenditures was necessary to provide the increase in services to the community compared to prior fiscal years. There was also \$202,276 of Quimby funds spent on one time capital projects.

**PLEASANT VALLEY RECREATION AND PARK DISTRICT**  
**Management's Discussion and Analysis**  
**Fiscal Year Ended June 30, 2024**

Condensed Statement of Revenues, Expenditures and Changes in Fund Balances

	June 30, <u>2024</u>	<u>2023</u>
<b>Revenues:</b>		
Charges for Services	\$ 4,730,812	\$ 6,261,868
Operating Grants and Contributions	77,547	162,473
Capital Grants and Contributions	62,001	1,751,709
<b>General Revenue</b>		
Property Taxes	8,827,361	8,285,029
Investment Income	1,189,574	430,840
Other	848,227	944,127
<b>Total Revenues</b>	<b>15,735,522</b>	<b>17,836,046</b>
<b>Expenses:</b>		
Recreation and Park Operations	11,560,850	11,522,779
<b>Excess of Revenue over (under)</b>		
<b>Expenditures</b>	<b>4,174,672</b>	<b>6,313,267</b>
<b>Net Change in Fund Balance</b>	<b>4,174,672</b>	<b>6,313,267</b>
Fund Balance - Beginning of Year	19,348,217	13,127,526
Prior Period Adjustment	(8,758)	(92,576)
<b>Net Position - End of Year</b>	<b>\$ 23,514,131</b>	<b>\$ 19,348,217</b>

Charges for Services includes programs, class fees, facility & other rental fees, cell tower income, senior services income, activity guide advertising income, indemnity income, Park Impact fees, and Quimby Fees. The Charges for Services decreased by \$1,531,056 (-24.45%) in part due to the loss of revenue from Quimby Fees of nearly \$3.8 million that were collected in Fiscal Year 2023.

Operating Grants (Habitat Conservation Fund & Community Development Block Grant) and Contributions decreased by \$84,926 (-52.27%) due to the exhausting of all Community Development Block Grant funds.

Capital Grants and Contributions were down by \$1,308,170 for the Miracle League of the 805 Ballfield at Freedom Park and \$443,539 of Prop 68 funding for renovations made at Arneill Ranch that were collected in Fiscal Year 2023 only.

Property tax revenue, the District's primary source of revenue, increased by \$542,332 (6.55%).

Investment income increased by \$758,734 due to high interest rates set by the Federal Reserve. The District has been able to capitalize on the increased interest rates.

Other Revenue decreased by \$95,900 (-10.16%). Other Revenue includes Recognized Obligation Payment Schedule (ROPS) payments from the Redevelopment Property Tax Trust Fund (RPTTF), Turf Mitigation rebates, and other administrative fees charged by the District. The District did not receive any Turf Mitigation rebates in Fiscal Year 2024.

**PLEASANT VALLEY RECREATION AND PARK DISTRICT**  
**Management's Discussion and Analysis**  
**Fiscal Year Ended June 30, 2024**

---

**GOVERNMENTAL FUND FINANCIAL STATEMENT ANALYSIS**

The focus of the District's governmental funds is to provide information on short-term inflows, outflows, and balances of spendable resources. Such information is useful in assessing the District's financing requirements. In particular, unassigned fund balance may serve as a useful measure of a government's net resources available for spending at the end of the fiscal year.

At the close of fiscal year 2023-2024, Total Governmental Funds reported an ending fund balance of \$23,514,131, an increase of \$4,165,914 (21.53%) in comparison with the prior fiscal year. Fund Balance is the net worth of a fund, found by calculating the assets and subtracting the liabilities. This increase is mainly due to the receipt of over \$1.8 million in Park Impact fees.

The following are the District's major funds:

**General Fund (Fund 10 and 60)**

The General Fund is the District's primary operating fund. The General Fund is composed of Fund 10-General Fund and Fund 60-Restricted Donations. Fund 10-General Fund expenditures have risen by \$412,328 (4.44%) as more programs and classes are offered and the District remains fully staffed with no remaining vacancies. Property Taxes in Fiscal Year 2023-2024 saw an overall 6.55% increase due to increased home buying/selling in Ventura County, contributing to a Fund 10-General Fund revenue increase of \$789,449 (7.03%). Fund 60- Restricted Donations completed construction of the Miracle League of the 805 Ballfield at Freedom Park, with final expenditures of \$433,837 for said ballfield this fiscal year.

The General Fund showed Revenues exceeded Expenditures, or net increase in fund balance (calculating the assets and subtracting the liabilities and deferred inflows of resources), of \$1,886,676 (page 14 of the audit report) in fiscal year 2023-2024, increase of \$2,319,931 for Fund 10-General Fund and decrease of \$433,837 for Fund 60-Restricted Donations.

**Special Assessment District Special Revenue Fund (Fund 20)**

The Special Assessment District Fund is used primarily for district-wide park landscape maintenance and to help with the payoff of the Pleasant Valley Fields COP. The Assessment District Fund showed Revenues exceeded Expenditures, or net increase in fund balance, of \$193,981.

**Park Dedication Fees (Quimby Fund-Fund 30)**

The Quimby Act was passed in 1975 and amended in 1982. This act requires developers to set aside land, donate a conservation easement, or pay fees for park improvements. Revenues generated through the Quimby Act cannot be used for the operation of parks or personnel. The District received no Quimby Funds in fiscal year 2023-2024 and collected \$397,596 in investment earnings. The District also made progress on some Capital Projects using Quimby fees, with total expenditures of \$202,276, leading to Revenues exceeding Expenditures, or net increase in fund balance, of \$195,320.

**Nonmajor Governmental Funds (Funds 40 and 50)**

**Park Impact Fees Fund 40:** On June 23, 2021, the City of Camarillo added Chapter 16.52 to the Camarillo Municipal Code. Chapter 16.52 establishes Park Impact Fees to any new residential construction, not subject to a subdivision, and new or expanded non-residential construction within the city. Revenues generated through Park Impact Fees cannot be used for the operation of parks or personnel. In fiscal year 2023-2024, the District received \$1,814,319 in Park Impact Fees and \$93,233 in Investment Earnings. Currently, no spending is being done from Fund 40. See Supplementary Information on Pages 46 and 47.

**CDBG Grant Fund 50:** In September of 2021, the District entered into an agreement with the City of Camarillo for U.S. Department of Housing and Urban Development (HUD) Community Development Block Grant (CDBG) funding. This funding is used to support food distribution for low-income families. CDBG funding reimburses the District for expenditures spent on a quarterly basis. The District received

**PLEASANT VALLEY RECREATION AND PARK DISTRICT**  
**Management's Discussion and Analysis**  
**Fiscal Year Ended June 30, 2024**

\$40,782 in revenue and had expenditures of \$40,782 for Fiscal Year 2023-2024, and has now fully expended all grant funding. There will be no more CDBG funding for this specific project. See Supplementary Information on Pages 47 and 48.

**CAPITAL ASSETS AND DEBT ADMINISTRATION**

*See Accompanying Information on Pages 27 and 28*

Capital Assets (net of accumulated depreciation)

June 30,

	<u>2024</u>	<u>2023</u>
Land	\$ 22,732,253	\$ 22,732,253
PV Fields	14,007,861	14,007,861
Freedom Fields	2,934,912	2,019,161
Land Improvements	11,315,998	9,800,560
Assessment Assets	128,560	128,560
Buildings, Structures, Impr.	10,873,688	10,792,423
Furniture, Fixtures, Equip.	473,035	444,367
Machinery & Heavy Equip.	710,670	553,373
Playground Equip.	1,620,784	1,560,891
Vehicles	540,231	511,271
Construction in Progress	670,128	2,362,446
Depreciation	<u>(25,871,493)</u>	<u>(24,708,137)</u>
Total Capital Assets, net	<u>\$ 40,136,627</u>	<u>\$ 40,205,029</u>

**Long-Term Liabilities**

The District's long-term liabilities as of period ending June 30, 2024 is \$19,103,295. There was a net decrease of \$664,951 from the fiscal year ended June 30, 2023. There are four major sources of long-term liabilities: (1) \$11,100,000 in the Certificate of Participation for the development of Pleasant Valley Fields Sports Complex, (2) Pension Liability of \$6,947,999, (3) Other Post-Employment Benefits Liability of \$570,208, and (4) \$428,482 in Compensated Absences. See Accompanying Information on Pages 29, 30, 31, and 35.

**Outstanding Long-Term Liabilities**

	<u>2024</u>	<u>2023</u>
Compensated Absences	\$ 428,482	\$ 471,807
2017 Certificates of Participation	11,100,000	11,425,000
Certificates of Participation Premium	56,606	59,460
Other Post-Employment Benefits	570,208	859,183
Net Pension Liability	<u>6,947,999</u>	<u>6,952,796</u>
<b>Total Outstanding Long-Term Liabilities</b>	<u><b>\$ 19,103,295</b></u>	<u><b>\$ 19,768,246</b></u>

**PLEASANT VALLEY RECREATION AND PARK DISTRICT**  
**Management's Discussion and Analysis**  
**Fiscal Year Ended June 30, 2024**

---

**ECONOMIC FACTORS**

The District's primary revenue source is property taxes, which continue to improve each fiscal year. The District has seen an increase in property tax revenue in fiscal year 2023-2024. While housing prices have remained steady, housing sales have slowed in the last year. Ventura County Assessor's tax appropriation for secured property showed a 5.47% increase for fiscal year 2023-2024 over the prior fiscal year. Additionally, the District has increased revenue from Charges for Services by 37.23% as the District continues to see more use of facilities and programs. The District has also increased personnel spending by 2.79% and materials and supplies spending by 14.63%. The increase in materials and supplies is due to the District increasing the level of service provided, which includes more District offerings.

Managing District resources in an environment of unstable revenues compounded by increasing costs is a challenge faced by the District. Consequently, resources for future capital maintenance, replacement, and new park and facility development must be either acquired from resources currently available in operating revenue, or additional revenue sources must be identified. The District continues to see significant increases in Liability Insurance premiums (12.3% increase in Fiscal Year 2024-2025) and CalPERS Unfunded Liability.

The state implemented pension reform on January 1, 2013, creating a third-tier retirement program with a new 2% at 62 formula for employees new to CalPERS. The District's other two plans are 2.5% at 55 and 2% at 60. On July 1, 2013, the Board of Directors took action that increased the employee contributions to the maximum allowed by state statute. One of the biggest economic factors for the District is the continued rising cost of CalPERS Unfunded Liability. For fiscal year 2024-2025 the District's minimum payment to CalPERS is expected to be \$608,761. This payment increased from the prior year payment of \$515,039. The District will decide for the Fiscal Year 2024-2025 budget if they will pay off the 2% @ 60 and 2% @ 62 plans, which are estimated to be \$38,000 combined.

**REQUEST FOR INFORMATION**

The District's financial report is designed to provide citizens, taxpayers, creditors, and investors with a general overview of PVRPD's finances and show accountability for the money it receives. Questions regarding any of the information provided in this report or to request additional information, please contact the District's General Manager at the Pleasant Valley Recreation and Park District, 1605 E. Burnley Street, Camarillo, California 93010 or call (805) 482-1996.





**BASIC FINANCIAL STATEMENTS**

**PLEASANT VALLEY RECREATION AND PARK DISTRICT**  
**STATEMENT OF NET POSITION**  
**JUNE 30, 2024**  
With Comparative Totals for June 30, 2023

	Total Governmental Activities	
	2024	2023
<b>ASSETS</b>		
Cash and investments	\$ 23,835,396	\$ 19,841,964
Accrued interest receivable	81,494	8,757
Accounts receivable	143,077	110,999
Property taxes and assessments receivable	345,279	307,106
Lease receivable - current	82,240	66,560
Prepaid items	4,758	14,780
Lease receivable - noncurrent	3,032,848	3,076,827
Capital assets - not being depreciated	23,402,381	25,094,699
Depreciable capital assets, net of accumulated depreciation	16,734,246	15,110,330
Total assets	<u>67,661,719</u>	<u>63,632,022</u>
<b>DEFERRED OUTFLOWS OF RESOURCES</b>		
Pensions	3,479,887	3,452,801
Other postemployment benefits	198,598	222,473
Deferred charge on debt refunding	444,056	474,322
Total deferred outflows of resources	<u>4,122,541</u>	<u>4,149,596</u>
<b>LIABILITIES</b>		
Accounts payable	458,764	233,656
Accrued salaries and benefits	116,100	224,676
Unearned revenue and customer deposits	468,131	527,929
Accrued interest payable	69,811	72,520
Long-term liabilities - due in one year		
Compensated absences	42,848	47,181
Certificates of participation	340,000	325,000
Certificates of participation premium	2,854	2,854
Long-term liabilities - due in more than one year		
Compensated absences	385,634	424,626
Other postemployment benefits payable	570,208	859,183
Certificates of participation	10,760,000	11,100,000
Certificates of participation premium	53,752	56,606
Net pension liability	6,947,999	6,952,796
Total liabilities	<u>20,216,101</u>	<u>20,827,027</u>
<b>DEFERRED INFLOWS OF RESOURCES</b>		
Leases	2,967,966	3,092,515
Pensions	647,956	827,637
Other postemployment benefits	755,676	500,354
Total deferred inflows of resources	<u>4,371,598</u>	<u>4,420,506</u>
<b>NET POSITION</b>		
Net investment in capital assets	29,424,077	29,194,891
Restricted	10,672,898	8,905,249
Unrestricted	7,099,586	4,433,945
Total net position	<u>\$ 47,196,561</u>	<u>\$ 42,534,085</u>

The accompanying notes are an integral part of this financial statement.

PLEASANT VALLEY RECREATION AND PARK DISTRICT  
STATEMENT OF ACTIVITIES  
FISCAL YEAR ENDED JUNE 30, 2024  
With Comparative Totals for Fiscal Year Ended June 30, 2023

Functions/Programs	Expenses	Program Revenues		Net (Expenses) Revenue and Changes in Net Position	2023	
		Charges for Services	Operating Contributions and Grants			Capital Contributions and Grants
Governmental Activities:						
Recreation and park operations	\$ 10,904,032	\$ 4,730,812	\$ 77,547	\$ 62,001	\$ (6,033,672)	\$ (694,263)
Total governmental activities	<u>\$ 10,904,032</u>	<u>\$ 4,730,812</u>	<u>\$ 77,547</u>	<u>\$ 62,001</u>	<u>(6,033,672)</u>	<u>(694,263)</u>
General Revenues:						
Property taxes					8,827,361	8,285,029
Investment earnings					1,189,574	430,840
Other revenues					848,227	944,127
Total general revenues					<u>10,865,162</u>	<u>9,659,996</u>
Change in net position					<u>4,831,490</u>	<u>8,965,733</u>
Net position - beginning of fiscal year					42,534,085	33,660,928
Prior period adjustments					<u>(169,014)</u>	<u>(92,576)</u>
Net position - beginning of fiscal year-restated					<u>42,365,071</u>	<u>33,568,352</u>
Net position - end of fiscal year					<u>\$ 47,196,561</u>	<u>\$ 42,534,085</u>

The accompanying notes are an integral part of this financial statement.

PLEASANT VALLEY RECREATION AND PARK DISTRICT  
BALANCE SHEET - GOVERNMENTAL FUNDS  
JUNE 30, 2024  
With Comparative Totals for June 30, 2023

	General Fund	Assessment District Fund	Quimby Fund	Nonmajor Governmental Funds	Total Governmental Funds	
					2024	2023
<b>ASSETS</b>						
Cash and investments	\$ 13,172,732	\$ 1,371,496	\$ 7,177,607	\$ 2,113,561	\$ 23,835,396	\$ 19,841,964
Accrued interest receivable	36,518		44,976		81,494	8,757
Accounts receivable	97,634	32,880		12,563	143,077	110,999
Property taxes and assessments receivable	345,279				345,279	307,106
Lease receivable	3,115,088				3,115,088	3,143,387
Prepaid expenditures	4,758				4,758	14,780
Total assets	<u>\$ 16,772,009</u>	<u>\$ 1,404,376</u>	<u>\$ 7,222,583</u>	<u>\$ 2,126,124</u>	<u>\$ 27,525,092</u>	<u>\$ 23,426,993</u>
<b>LIABILITIES, DEFERRED INFLOWS OF RESOURCES, AND FUND BALANCES</b>						
<b>Liabilities</b>						
Accounts payable and accrued expenditures	\$ 378,579	\$ 79,346	\$ 839	\$ -	\$ 458,764	\$ 233,656
Accrued salaries and benefits	116,100				116,100	224,676
Deposits	39,001				39,001	89,714
Unearned revenue	429,130				429,130	438,215
Total liabilities	<u>962,810</u>	<u>79,346</u>	<u>839</u>		<u>1,042,995</u>	<u>986,261</u>
<b>Deferred Inflows of Resources</b>						
Leases	2,967,966				2,967,966	3,092,515
Total deferred inflows of resources	<u>2,967,966</u>				<u>2,967,966</u>	<u>3,092,515</u>
<b>Fund Balances</b>						
Nonspendable:						
Prepays	4,758				4,758	14,780
Leases	147,122				147,122	50,872
Restricted:						
Specified park projects		1,325,030	7,221,744	2,126,124	10,672,898	8,393,660
Miracle League 805 field construction						511,589
Assigned:						
Compensated absences	428,482				428,482	471,807
Postemployment benefits payable	570,208				570,208	859,183
Unassigned	11,690,663				11,690,663	9,046,326
Total fund balances	<u>12,841,233</u>	<u>1,325,030</u>	<u>7,221,744</u>	<u>2,126,124</u>	<u>23,514,131</u>	<u>19,348,217</u>
Total liabilities, deferred inflows of resources, and fund balances	<u>\$ 16,772,009</u>	<u>\$ 1,404,376</u>	<u>\$ 7,222,583</u>	<u>\$ 2,126,124</u>	<u>\$ 27,525,092</u>	<u>\$ 23,426,993</u>

The accompanying notes are an integral part of this financial statement.

PLEASANT VALLEY RECREATION AND PARK DISTRICT  
RECONCILIATION OF THE GOVERNMENTAL FUNDS BALANCE  
SHEET TO THE STATEMENT OF NET POSITION  
JUNE 30, 2024

---

Total fund balances - governmental funds \$ 23,514,131

Amounts reported for governmental activities in the statement of net position are different because:

Capital assets: In governmental funds, only current assets are reported. In the statement of net position, all assets are reported, including capital assets and accumulated depreciation. Net capital assets consist of:

Capital assets	\$	66,008,120	
Accumulated depreciation		<u>(25,871,493)</u>	
			40,136,627

Interest payable: In governmental funds, interest on long-term debt is not recognized until the period in which it matures and is paid. In the government-wide statements of activities, it is recognized in the period it is incurred. (69,811)

Long-term liabilities: In governmental funds, only current liabilities are reported. In the statement of net position, all liabilities, including long-term liabilities, are reported. Long-term liabilities relating to governmental activities consist of:

Certificates of participation	\$	(11,100,000)	
Certificates of participation premiums		(56,606)	
Compensated absences		(428,482)	
Other postemployment benefits		(570,208)	
Net pension liability		<u>(6,947,999)</u>	
			(19,103,295)

In governmental funds, loss on debt refunding is recognized as an expenditure in the period incurred. In the government-wide statements, loss on debt refunding is amortized over the life of the debt. 444,056

Deferred outflows and inflows of resources relating to pensions and other postemployment benefits: In governmental funds, deferred outflows and inflows of resources relating to pensions and other postemployment benefits are not reported because they are applicable to future periods. In the statement of net position, deferred outflows and inflows of resources relating to pensions and other postemployment benefits are reported.

Deferred inflows of resources relating to pensions	\$	(647,956)	
Deferred inflows of resources relating to other postemployment benefits		(755,676)	
Deferred outflows of resources relating to pensions		3,479,887	
Deferred outflows of resources relating to other postemployment benefits		<u>198,598</u>	
			<u>2,274,853</u>

Total net position - governmental activities \$ 47,196,561

The accompanying notes are an integral part of this financial statement.

PLEASANT VALLEY RECREATION AND PARK DISTRICT  
GOVERNMENTAL FUNDS  
STATEMENT OF REVENUES, EXPENDITURES, AND CHANGES IN FUND BALANCES  
FISCAL YEAR ENDED JUNE 30, 2024  
With Comparative Totals for Fiscal Year Ended June 30, 2023

	General Fund	Assessment District Fund	Quimby Fund	Nonmajor Governmental Funds	Total Governmental Funds	
					2024	2023
<b>Revenues</b>						
Property taxes	\$ 8,827,361	\$ -	\$ -	\$ -	\$ 8,827,361	\$ 8,285,029
Charges for services:						
Special assessments and fees		1,313,352			1,313,352	5,044,561
Ordinance fees				1,814,319	1,814,319	49,071
Registration and other fees	915,911				915,911	728,931
Facility and other rental fees	687,230				687,230	439,305
Operating grants and contributions	36,765			40,782	77,547	162,473
Capital grants and contributions	62,001				62,001	1,751,709
Investment earnings	646,802	51,943	397,596	93,233	1,189,574	430,840
Other revenues	848,227				848,227	944,127
Total revenues	<u>12,024,297</u>	<u>1,365,295</u>	<u>397,596</u>	<u>1,948,334</u>	<u>15,735,522</u>	<u>17,836,046</u>
<b>Expenditures</b>						
Current:						
Salaries and benefits	5,185,445	81,519		31,204	5,298,168	5,174,391
Materials and services	3,670,690	681,015		18,435	4,370,140	3,813,988
Capital outlay	940,446		202,276		1,142,722	1,653,362
Debt service:						
Principal		325,000			325,000	440,000
Interest	341,040	83,780			424,820	441,038
Total expenditures	<u>10,137,621</u>	<u>1,171,314</u>	<u>202,276</u>	<u>49,639</u>	<u>11,560,850</u>	<u>11,522,779</u>
Net change in fund balances	<u>1,886,676</u>	<u>193,981</u>	<u>195,320</u>	<u>1,898,695</u>	<u>4,174,672</u>	<u>6,313,267</u>
Fund balances - beginning of fiscal year	10,954,557	1,131,049	7,035,182	227,429	19,348,217	13,127,526
Prior-period adjustments			(8,758)		(8,758)	(92,576)
Fund balances - beginning of fiscal year, restated	<u>10,954,557</u>	<u>1,131,049</u>	<u>7,026,424</u>	<u>227,429</u>	<u>19,339,459</u>	<u>13,034,950</u>
Fund balances - end of fiscal year	<u>\$ 12,841,233</u>	<u>\$ 1,325,030</u>	<u>\$ 7,221,744</u>	<u>\$ 2,126,124</u>	<u>\$ 23,514,131</u>	<u>\$ 19,348,217</u>

The accompanying notes are an integral part of this financial statement.

**PLEASANT VALLEY RECREATION AND PARK DISTRICT**  
**RECONCILIATION OF GOVERNMENTAL FUNDS STATEMENT OF REVENUES,**  
**EXPENDITURES, AND CHANGES IN FUND BALANCES TO THE STATEMENT OF ACTIVITIES**  
**FISCAL YEAR ENDED JUNE 30, 2024**

---

Total net change in fund balances - governmental funds \$ 4,174,672

Amounts reported for governmental activities in the statement of activities are different because:

Capital outlays are reported in governmental funds as expenditures. However, in the statement of activities, the cost of capital assets is allocated over their estimated useful lives as depreciation expense. This is the amount by which additions to capital assets is more than depreciation expense.

Capital outlays which were capitalized as capital assets	\$	1,128,260	
Depreciation expense		(1,033,990)	
Loss on disposal of capital assets		<u>(2,416)</u>	
			91,854

In governmental funds, compensated absences are measured by the amounts paid during the period. In the statement of activities, compensated absences are measured by the amounts earned. The differences between compensated absences earned and compensated absences paid was: 43,325

In governmental funds, repayments of long-term debt are reported as expenditures. In the government-wide statements, repayments of long-term debt are reported as reductions of liabilities. 325,000

In governmental funds, if debt is issued at a premium, the premium is recognized as an Other Financing Source in the period it is incurred. In the government-wide statements, the premium is amortized as interest over the life of the debt. Amortization of debt issue premium for the period was: 2,854

In governmental funds, interest on long-term debt is recognized in the period that it becomes due. In the government-wide statement of activities, it is recognized in the period that it is incurred. Unmatured interest owing at the end of the period, less matured interest paid during but owing from the prior period was: 2,709

In governmental funds, loss on debt refunding is recognized as an expenditure in the period they are incurred. In the government-wide statements, the loss is amortized over the life of the debt. Loss on debt refunding amortization for the period was: (30,266)

In governmental funds, OPEB costs are recognized when employer contributions are made. In the statement of activities, OPEB costs are recognized on the accrual basis. This fiscal year, the difference between accrual basis OPEB costs and actual employer contributions was: 9,778

In governmental funds, pension costs are recognized when employer contributions are made. In the statement of activities, pension costs are recognized on the accrual basis. This year, the difference between accrual-basis pension costs and actual employer contributions was: 211,564

Total change in net position - governmental activities \$ 4,831,490

The accompanying notes are an integral part of this financial statement.

**PLEASANT VALLEY RECREATION AND PARK DISTRICT**  
**STATEMENT OF FIDUCIARY NET POSITION**  
 June 30, 2024  
 With Comparative Totals for June 30, 2023

---

	Part-Time Employees Retirement Trust Fund	
	2024	2023
<b>Assets</b>		
Cash and investments	\$ 74,273	\$ 70,534
Total assets	<u>74,273</u>	<u>70,534</u>
<b>Net Position</b>		
Retirement funds payable to recipients	74,273	70,534
Total net position	<u>\$ 74,273</u>	<u>\$ 70,534</u>

The accompanying notes are an integral part of this financial statement.



**PLEASANT VALLEY RECREATION AND PARK DISTRICT**  
**STATEMENT OF CHANGES IN FIDUCIARY NET POSITION**  
 Fiscal Year Ended June 30, 2024  
 With Comparative Totals for Fiscal Year Ended June 30, 2023

---

	Part-Time Employees Retirement Trust Fund	
	2024	2023
<b>Additions</b>		
Contributions to retirement trust fund	\$ -	\$ -
Investment earnings	3,739	2,119
Total revenues	<u>3,739</u>	<u>2,119</u>
<b>Deductions</b>		
Claims paid or payable to claimant		6,871
Total deductions		<u>6,871</u>
Change in net position	3,739	(4,752)
Net position - beginning of fiscal year	<u>70,534</u>	<u>75,286</u>
Net position - end of fiscal year	<u>\$ 74,273</u>	<u>\$ 70,534</u>

The accompanying notes are an integral part of this financial statement.

**NOTE 1 - SUMMARY OF SIGNIFICANT ACCOUNTING POLICIES**

**A. Organization and Reporting Entity**

The Pleasant Valley Recreation & Park District (the District) is located in and around the City of Camarillo, approximately 10 miles inland from the Pacific Ocean. The District was formed in January 1962 under the State Public Resource Code of California. The District serves an area of approximately 45 square miles and has grown from one park to 28 parks since its inception 62 years ago. Within the District, a variety of recreational facilities exist including: indoor swimming pool, lighted ball fields, tennis courts, racquetball courts, a running track, children's play equipment, picnic shelters, barbecues and much more. General administration and management of the District is under the direction of a five-member Board of Directors and a General Manager.

The District's basic financial statements include the operations of which the District's Board of Directors exercises oversight responsibility. There are no component units included in this report which meet the criteria of the GASB Statement No. 14, *The Financial Reporting Entity*, as amended by GASB Statements No. 39, No. 61, No. 80, and No. 90.

**B. Basis of Accounting, Measurement Focus, and Financial Statement Presentation**

The District's basic financial statements are prepared in conformity with accounting principles generally accepted in the United States of America. The Governmental Accounting Standards Board (GASB) is the acknowledged standard setting body for establishing accounting and financial reporting standards followed by governmental entities in the United States of America.

The *basic financial statements* of the District are composed of the following:

- Government-wide financial statements
- Fund financial statements
- Notes to the basic financial statements

Government-wide Financial Statements

Government-wide financial statements display information about the reporting government as a whole. These statements include separate columns for the governmental activities of the primary government. Eliminations have been made in the Statement of Activities so that certain allocated expenses are recorded only once (by the function to which they were allocated). However, general government expenses have not been allocated as indirect expenses to the various functions of the District.

Government-wide financial statements are presented using the *economic resources measurement focus* and the *accrual basis of accounting*. Under the economic resources measurement focus, all (both current and long-term) economic resources and obligations of the reporting government are reported in the government-wide financial statements. *Basis of accounting* refers to when revenues and expenses are recognized in the accounts and reported in the financial statements. Under the accrual basis of accounting, revenues, expenses, gains, losses, assets, and liabilities resulting from exchange and exchange-like transactions are recognized when the exchange takes place. Revenues, expenses, gains, losses, assets, and liabilities resulting from nonexchange transaction are recognized in accordance with the requirements of GASB Statement No. 33.

The types of transactions reported as program revenues for the District are to be reported in three categories, if applicable: 1) charges for services, 2) operating grants and contributions, and 3) capital grants and contributions. Charges for services include revenues from customers or applicants who purchase, use, or directly benefit from goods, services, or privileges provided by a given function. Grants and contributions include revenues restricted to meeting the operational or capital requirements of a particular function. Program revenues are netted with program expenses in the statement of activities to present the net cost of each program. Taxes and other items not properly included among program revenues are reported instead as general revenues.

Amounts paid to acquire capital assets are capitalized as assets in the government-wide financial statements, rather than reported as an expenditure. Proceeds of long-term debt are recorded as a liability in the government-wide financial statements, rather than as another financing source. Amounts paid to reduce long-term indebtedness of the reporting government are reported as a reduction of the related liability, rather than as an expenditure.

**NOTE 1 - SUMMARY OF SIGNIFICANT ACCOUNTING POLICIES (continued)**

**B. Basis of Accounting, Measurement Focus, and Financial Statement Presentation (continued)**

Fund Financial Statements

Fund financial statements report detailed information about the District. The focus of governmental fund financial statements is on major funds rather than reporting funds by type. Each major governmental fund is presented in a separate column, and all nonmajor funds are aggregated into one column, however the District has no nonmajor funds. Fiduciary funds are reported by fund type.

The accounting and financial treatment applied to a fund is determined by its measurement focus. All governmental funds are accounted for using a flow of current financial resources measurement focus. With the measurement focus, only current assets and current liabilities are generally included on the balance sheet. The Statement of Revenues, Expenditures, and Changes in Fund Balances for these funds present increases, (i.e., revenues and other financing sources) and decreases (i.e. expenditures and other financing uses) in net position.

Fiduciary funds are reported using the economic resources measurement focus.

Governmental Funds

In the fund financial statements, governmental funds are presented using the *modified - accrual basis of accounting*. Their revenues are recognized when they become *measurable* and *available* as net current position. *Measurable* means that the amounts can be estimated, or otherwise determined. *Available* means that the amounts were collected during the reporting period or soon enough thereafter to be available to finance the expenditures accrued for the reporting period. Revenue recognition is subject to the *measurable* and *availability* criteria for the governmental funds in the fund financial statements. *Exchange transactions* are recognized as revenues in the period in which they are earned (i.e., the related goods or services are provided). *Locally imposed derived tax revenues* are recognized as revenues in the period in which the underlying exchange transaction, upon which they are based, takes place. *Imposed nonexchange transactions* are recognized as revenues in the period for which they were imposed. If the period of use is not specified, they are recognized as revenues when an enforceable legal claim to the revenues arises or when they are received, whichever occurs first. *Government-mandated and voluntary nonexchange transactions* are recognized as revenues when all applicable eligibility requirements have been met.

In the fund financial statements, governmental funds are presented using the *current financial resources measurement focus*. This means that only current assets and current liabilities are generally included on their balance sheets. The reported fund balance is considered to be a measure of “available spendable resources”. Governmental fund operating statements present increases (revenues and other financing sources) and decreases (expenditures and other financing uses) in net position. Accordingly, they are said to present a summary of sources and uses of “available spendable resources” during a period.

Non-current portions of long-term receivables due to governmental funds are reported on their balance sheets in spite of their spending measurement focus. Special reporting treatments are used to indicate, however, that they should not be considered “available spendable resources,” since they do not represent net current position. Recognition of governmental fund type revenue represented by non-current receivables are deferred until they become current receivables. Because of their spending measurement focus, expenditure recognition for governmental fund types excludes amounts represented by noncurrent liabilities. Since they do not affect net position, such long-term amounts are not recognized as governmental fund type expenditures or fund liabilities.

Amounts expended to acquire capital assets are recorded as *expenditures* in the fiscal year that resources were expended, rather than as fund assets. The proceeds of long-term debt are recorded as *other financing sources* rather than as a fund liability. Amounts paid to reduce long-term indebtedness are reported as fund expenditures.

When both restricted and unrestricted resources are combined in a fund, expenditures/expenses are considered to be paid first from restricted resources, and then from unrestricted resources.

**NOTE 1 - SUMMARY OF SIGNIFICANT ACCOUNTING POLICIES (continued)**

**B. Basis of Accounting, Measurement Focus, and Financial Statement Presentation (continued)**

Governmental Funds (Continued)

GASB Statement No. 34 defines major funds and requires that the District's major funds are identified and presented separately in the fund financial statements. All other funds, called nonmajor funds, are combined and reported in a single column in the Fund Statements as Other Governmental Funds, regardless of their fund-type.

Major funds are defined as funds that have either assets plus deferred outflows, liabilities plus deferred inflows, revenues, or expenditures/expenses at least ten percent of their fund-type total and at least five percent of the total for all funds. The General Fund is always a major fund. The District may also voluntarily select other funds it believes should be presented as major funds.

The District reports the following major governmental funds:

- **General Fund** is the primary operating fund of the District. It is used to account for all financial resources except those required to be accounted for in another fund.
- **Assessment District Fund** is used for the assessment revenues and expenditures from a special assessment for specific park and recreation facilities and operations.
- **Quimby Fees Fund** is used to track the Quimby fees collected by the District to expand, acquire, rehabilitate or develop community-servicing parks.

The District reports the following nonmajor governmental funds:

- **Park Impact Fees Fund** is used to track the Park Impact Fees collected by the District.
- **CDBG Fund** is used for the CDBG funded food service program.

The District reports the following fiduciary fund:

- **Part-Time Employees Retirement Trust Fund** holds funds in trust for part-time employees who are enrolled in the non-elective deferred compensation plan arrangement for the benefit of employees who are not covered by another retirement system maintained by the District (see Note 9).

Basis of accounting refers to when revenues and expenditures are recognized in the accounts and reported in the financial statements. Government-wide financial statements are prepared using the accrual basis of accounting. Governmental funds use the modified accrual basis of accounting. Fiduciary funds use the accrual basis of accounting.

**C. Estimates**

The preparation of financial statements in conformity with accounting principles generally accepted in the United States of America, as prescribed by the GASB and the AICPA, requires management to make estimates and assumptions that affect the reported amounts of assets and liabilities and disclosure of contingent assets and liabilities at the date of the financial statements and the reported amounts of revenues and expenditures/expenses during the reporting period. Actual results could differ from those estimates.

**D. Investments and Investment Policy**

The District has adopted an investment policy directing the General Manager to deposit funds in financial institutions. No more than 30% of the District's total investment portfolio will be invested in a single security type or with a single financial institution with the exceptions of U.S. Government Treasury securities, Ventura County Investment Pool, and LAIF. Investments can only be made in the following areas:

U.S. Government Securities	Repurchase Agreements
Banker's Acceptances	Local Agency Investment Fund (LAIF)
Commercial Paper	Money Market Accounts
Negotiable Certificates of Deposit	Savings Deposits
Ventura County Investment Pool	

**NOTE 1 - SUMMARY OF SIGNIFICANT ACCOUNTING POLICIES (continued)**

**D. Investments and Investment Policy (continued)**

Changes in fair value that occur during a fiscal year are recognized as unrealized gains or losses and reported for that fiscal year. Investment income is comprised of investment earnings, changes in fair value, and any gains or losses realized upon the liquidation or sale of investments.

Local Agency Investment Fund

LAIF is regulated by California Government Code (Code) Section 16429 and is under the management of the State of California Treasurer’s Office with oversight provided by the Local Agency Investment Advisory Board.

LAIF is carried at fair value based on the value of each participating dollar as provided by LAIF. The fair value of the District’s position in LAIF is the same as the value of its pooled shared. Investments in securities of the U.S. government or its agencies are carried at fair value based on quoted market prices. Bank balances are secured by the pledging of a pool of eligible securities to collateralize the District’s deposits with the bank in accordance with the Code.

**E. Property Taxes and Special Assessments**

The County of Ventura Assessor's Office assesses all real and personal property within the County each year. The County of Ventura Tax Collector's Office bills and collects the District's share of property taxes and special assessments. The County of Ventura Treasurer's Office remits current and delinquent property tax collections to the District throughout the year. Property tax in California is levied in accordance with Article 13A of the State Constitution at one percent (1%) of county-wide assessed valuations.

Property taxes and special assessments receivable at fiscal year-end are related to property taxes collected by the County of Ventura which have not been credited to the District's cash balance as of June 30. The property tax calendar is as follows:

Lien date	January 1
Levy date	July 1
Due dates	November 1 and March 1
Collection dates	December 10 and April 10

**F. Prepaid Items**

Certain payments to vendors reflect costs or deposits applicable to future accounting periods and are recorded as prepaid items in both the government-wide and fund financial statements.

**G. Capital Assets**

Capital assets are recorded in the government-wide financial statements. Included in capital assets are PV Fields assets, land, buildings, building improvements, equipment, furniture and fixtures, and vehicles. District policy has set the capitalization threshold for reporting capital assets at \$5,000. Donated assets are recorded at estimated fair value at the date of donation. Capital outlay is recorded as expenditures of the governmental funds and as capital assets in the government-wide financial statements to the extent the District's capitalization threshold is met. Depreciation is recorded on a straight-line basis over the estimated useful lives of the assets as follows:

Description	Years	Description	Years
PV Fields — Buildings	39	Land improvements	15
PV Fields — Land grading	39	Assessment assets	15
PV Fields — Land improvements	39	Buildings, structures, and improvements	10 to 39
PV Fields — Lighting	39	Furniture, fixtures, and office equipment	5 to 7
PV Fields — Other assets	5	Machinery and heavy equipment	3 to 10
PV Fields — Playground equipment	15	Playground equipment	15
PV Fields — Turf and landscaping	10	Vehicles	5
FB Fields — Ball Fields	20	FB Fields — Land improvements	20
FB Fields — Lighting	20	FB Fields — Land Grading	20
FB Fields — Turf and Landscape	20		

**NOTE 1 - SUMMARY OF SIGNIFICANT ACCOUNTING POLICIES (continued)**

**H. Compensated Absences**

The District's policy is to permit full-time and part-time year-round employees to accumulate earned vacation time, sick leave, and compensating time. Earned vacation time shall be earned by each employee subject to the accrual limitations and policies as follows for union employees:

<u>Years of Service</u>	<u>Annual Accrual Hours</u>	<u>Maximum Accrual Hours</u>
Less than 5 years of service	80	240
Over 5 years but less than 11	120	360
Over 11 years but less than 12	128	384
Over 12 years but less than 13	136	408
Over 13 years but less than 14	144	432
Over 14 years but less than 16	152	456
16 years or more	160	480
Part-time year-round	40	80

For non-union employees, each employee is subject to the accrual limitations below for full-time and part-time year-round respectively:

<u>Years of Service</u>	<u>Annual Accrual</u>	<u>Maximum Accrual</u>
0-5 Years	80	160
6-8 Years	100	200
9-12 Years	120	240
13-15 Years	140	280
15+ Years	160	320

<u>Years of Service</u>	<u>Annual Accrual</u>	<u>Maximum Accrual</u>
0-5 Years	60	80
6-8 Years	75	100
9-12 Years	90	120
13-15 Years	105	140
15+ Years	120	160

Sick leave that is not used shall accumulate during subsequent years without limitation for full-time employees and will be capped at 80 hours for part-time year-round employees. Sick leave cannot be converted to vacation time, but in order to reward employees who do not utilize all of their sick leave, the District will compensate employees with 10 plus years of employment fifty percent (50%) of the unused sick leave up to 1,000 hours; employees with 5-10 years of service will be compensated at twenty-five percent (25%) of the unused sick leave up to 500 hours.

**I. Pensions**

For purposes of measuring the net pension liability and deferred outflows/inflows of resources related to pensions, and pension expense, information about the fiduciary net position of the Pleasant Valley Recreation and Park District's California Public Employee's Retirement System (CalPERS) plans (Plans) and additions to/deductions from the Plans' fiduciary net position have been determined on the same basis as they are reported by CalPERS. For this purpose, benefit payments (including refunds of employee contributions) are recognized when due and payable in accordance with the benefit terms. Investments are reported at fair value.

**J. Deferred Outflows and Inflows of Resources**

Pursuant to GASB Statement No. 63, "Financial Reporting of Deferred Outflows of Resources, Deferred Inflows of Resources, and Net Position," and GASB Statement No. 65, "Items Previously Reported as Assets and Liabilities," the District recognizes deferred outflows and inflows of resources.

**NOTE 1 - SUMMARY OF SIGNIFICANT ACCOUNTING POLICIES (continued)**

**J. Deferred Outflows and Inflows of Resources (continued)**

In addition to assets, the Statement of Net Position will sometimes report a separate section for deferred outflows of resources. A deferred outflow of resources is defined as a consumption of net position by the government that is applicable to a future reporting period. The District has three items which qualify for reporting in this category; refer to Notes 5, 6 and Note 10 for a detailed listing of the deferred outflows of resources the District has reported.

In addition to liabilities, the Statement of Net Position will sometimes report a separate section for deferred inflows of resources. A deferred inflow of resources is defined as an acquisition of net position by the District that is applicable to a future reporting period. The District has two items which qualify for reporting in this category; refer to Notes 5, 6, and Note 11 for a detailed listing of the deferred inflows of resources the District has reported.

**K. Budgets**

The budget is reported on the same basis as the fund types and on a basis consistent with accounting principles generally accepted in the United States of America. Additional appropriations or other changes during the fiscal year may be submitted by the department for Board review and approval.

**L. Net Position**

GASB Statement No. 63 requires that the difference between assets added to the deferred outflows of resources and liabilities added to the deferred inflows of resources be reported as net position. Net position is classified as either net investment in capital assets, restricted, or unrestricted.

Net position that is net investment in capital assets consist of capital assets, net of accumulated depreciation, and reduced by the outstanding principal of related debt. Restricted net position is the portion of net position that has external constraints placed on it by creditors, grantors, contributors, laws, or regulations of other governments, or through constitutional provisions or enabling legislation. Unrestricted net position consists of net position that does not meet the definition of net investment in capital assets or restricted net position.

**M. Fund Balances**

In the financial statements, governmental funds report fund balances as non-spendable, restricted, committed, assigned, or unassigned based primarily on the extent to which the District is bound to honor constraints on how specific amounts can be spent.

- Non-spendable fund balance — amounts that cannot be spent because they are either (a) not in spendable form or (b) legally or contractually required to be maintained intact.
- Restricted fund balance — amounts with constraints placed on their use that are either (a) externally imposed by creditors, grantors, contributors, or laws or regulations of other governments; or (b) imposed by law through constitutional provisions or enabling legislation.
- Committed fund balance — amounts that can only be used for specific purposes determined by formal action of the District's highest level of decision-making authority (the Board of Directors) and that remain binding unless removed in the same manner. The underlying action that imposed the limitation needs to occur no later than the close of the reporting period.
- Assigned fund balance — amounts that are constrained by the District's intent to be used for specific purposes. The intent can be established at either the highest level of decision-making, or by a body or an official designated for that purpose.
- Unassigned fund balance — the residual classification for the District's general fund that includes amounts not contained in the other classifications. In other funds, the unassigned classification is used only if expenditures incurred for specific purposes exceed the amounts restricted, committed, or assigned to those purposes.

The Board of Directors establishes, modifies or rescinds fund balance commitments and assignments by passage of an ordinance or resolution. This is done through adoption of the budget and subsequent budget amendments that occur throughout the fiscal year.

**NOTE 1 - SUMMARY OF SIGNIFICANT ACCOUNTING POLICIES (continued)**

**M. Fund Balances (continued)**

When both restricted and unrestricted resources are available for use, it is the District's policy to use restricted resources first, followed by the unrestricted, committed, assigned, and unassigned resources as they are needed.

Fund Balance Policy

The District believes that sound financial management principles require that sufficient funds be retained by the District to provide a stable financial base at all times. To retain this stable financial base, the District needs to maintain an unrestricted fund balance in its funds sufficient to fund cash flows of the District and to provide financial reserves for unanticipated expenditures and/or revenue shortfalls of an emergency nature. Committed, assigned, and unassigned fund balances are considered unrestricted.

The purpose of the District's fund balance policy is to maintain a prudent level of financial resources to protect against reducing service levels or raising taxes and fees because of temporary revenue shortfalls or unpredicted one-time expenditures.

**N. Comparative Data/Totals Only**

Comparative total data for the prior fiscal year has been presented in certain accompanying financial statements in order to provide an understanding of the changes in the District's financial position and operations. Also, certain prior fiscal amounts have been reclassified to conform to the current fiscal year financial statements presentation.

**O. Other Post-Employment Benefits (OPEB)**

For purposes of measuring the net OPEB liability and deferred outflows/inflows of resources related to OPEB, and OPEB expense, information about the fiduciary net position of the District's plan (OPEB Plan) and additions to/deductions from the Plan's fiduciary net position have been determined on the same basis. For this purpose, benefit payments are recognized when due and payable in accordance with the benefit terms. Investments are reported at fair value.

**P. Amortization of Loss on Debt Refunding**

The loss on debt refunding is being amortized on the straight line method over the life of the bonds in the government-wide financial statements.

**Q. Lease Receivable**

The District's lease receivable is measured at the present value of lease payments expected to be received during the lease term. A deferred inflow of resources is recorded for the lease. The deferred inflow of resources is recorded at the initiation of the lease in an amount equal to the initial recording of the lease receivable. The deferred inflow of resources is amortized on a straight-line basis over the life of the related lease.

**R. Future Accounting Pronouncements**

GASB Statements listed below will be implemented in future financial statements:

Statement No. 101	"Compensated Absences"	The provisions of this statement are effective for fiscal years beginning after December 15, 2023.
Statement No. 102	"Certain Risk Disclosures"	The provisions of this statement are effective for fiscal years beginning after June 15, 2024.
Statement No. 103	"Financial Reporting Model Improvements"	The provisions of this statement are effective for fiscal years beginning after June 15, 2025.
Statement No. 104	"Disclosure of Certain Capital Assets"	The provisions of this statement are effective for fiscal years beginning after June 15, 2025.



**PLEASANT VALLEY RECREATION AND PARK DISTRICT**  
**NOTES TO BASIC FINANCIAL STATEMENTS**  
 June 30, 2024

**NOTE 2 - CASH AND INVESTMENTS**

Cash at June 30, 2024, consists of the following:

Cash on hand	\$ 892
Deposits held with financial institutions	18,317,563
Investments	<u>5,591,214</u>
Total cash and investments	<u>\$ 23,909,669</u>

Cash and investments are presented on the accompanying basic financial statements, as follows below:

Cash and investments, statement of net position	\$ 23,835,396
Cash and investments, statement of fiduciary net position	<u>74,273</u>
Total cash and investments	<u>\$ 23,909,669</u>

The District categorizes its fair value measurements within the fair value hierarchy established by U.S. Generally Accepted Accounting Principles. The hierarchy is based on the valuation inputs used to measure the fair value of the asset. Level 1 inputs are quoted prices in active markets for identical assets; Level 2 inputs are significant other observable inputs; Level 3 inputs are significant unobservable inputs. The District had investments in the Ventura County Investment Pool and in LAIF which are not measured under levels 1, 2, or 3.

Authorized Deposits and Investments

Under provisions of the District's investment policy, and in accordance with Section 53601 of the California Government Code, the District may invest in certain types of investments as listed in Note 1(D) to the financial statements.

Interest Rate Risk

Interest rate risk is the risk that changes in market interest rates will adversely affect the fair value of an investment. The longer the maturity of an investment has the greater its fair value is sensitive to changes in market interest rates. The District's investment policy follows the Code as it relates to limits on investment maturities as a means of managing exposure to fair value losses arising from increasing interest rates.

Information about the sensitivity of the fair values of the District's investments to market interest rate fluctuations is provided by the table on the following page that shows the distribution of the District's investments by maturity:

Investment Type	Carrying Amount	Remaining Maturity (in Months)			
		12 Months Or Less	13-24 Months	25-60 Months	More than 60 Months
State investment pool (LAIF)	\$ 2,895,061	\$ 2,895,061	\$ -	\$ -	\$ -
Ventura County Investment Pool	<u>2,696,153</u>	<u>2,696,153</u>			
	<u>\$ 5,591,214</u>	<u>\$ 5,591,214</u>	<u>\$ -</u>	<u>\$ -</u>	<u>\$ -</u>

Credit Risk

State law limits investments in commercial paper, corporate bonds, and mutual bond funds to the top two ratings issued by nationally recognized statistical rating organizations. The District has no investment policy that would further limit its investment choices. LAIF and the Ventura County Investment Pool investment funds are unrated.

Investment Type	Carrying Amount	Minimum Legal Rating	Rating as of Fiscal Year End			
			AAA	A+	Baa	Not Rated
State investment pool (LAIF)	\$ 2,895,061	N/A	\$ -	\$ -	\$ -	\$ 2,895,061
Ventura County Investment Pool	<u>2,696,153</u>	N/A				<u>2,696,153</u>
	<u>\$ 5,591,214</u>		<u>\$ -</u>	<u>\$ -</u>	<u>\$ -</u>	<u>\$ 5,591,214</u>

**NOTE 2 - CASH AND INVESTMENTS (continued)**

Concentration of Credit Risk

The investment policy of the District contains no limitations on the amount that can be invested in any one issuer beyond that stipulated by the California Government Code. There are no investments in any one issuer that represent 5% or more of the total District's investments.

Custodial Credit Risk

Custodial credit risk for *deposits* is the risk that, in the event of the failure of a depository financial institution, a government will not be able to recover its deposits or will not be able to recover collateral securities that are in the possession of an outside party.

The California Government Code and the District's investment policy do not contain legal or policy requirements that would limit the exposure to custodial credit risk for deposits, other than the following provision for deposits: The California Government Code requires that a financial institution secure deposits made by State or local governmental units by pledging securities in an undivided collateral pool held by a depository regulated under State law (unless so waived by the governmental unit). The fair value of the pledged securities in the collateral pool must equal at least 110% of the total amount deposited by the public agencies. California law also allows financial institutions to secure the District's deposits by pledging first trust deed mortgage notes having a value of 150% of the secured public deposits.

None of the District's deposits with financial institutions in excess of the Federal Depository Insurance Corporation's limits were held in uncollateralized accounts.

The custodial credit risk for *investments* is the risk that, in the event of the failure of the counterparty (e.g., broker-dealer) to a transaction, a government will not be able to recover the value of its investment or collateral securities that are in the possession of another party. The California Government Code and the District's investment policy do not contain legal or policy requirements that would limit the exposure to custodial credit risk for investments. With respect to investments, custodial credit risk generally applies only to direct investments in marketable securities. Custodial credit risk does not apply to a local government's indirect investment in securities through the use of mutual funds or governmental investment pools (such as LAIF and the Ventura County Investment Pool).

Investment in State Investment Pool

The District is a voluntary participant in the Local Agency Investment Fund (LAIF) that is regulated by the California Government Code Section 16429 under the oversight of the Treasurer of the State of California. The fair value of the District's investment in this pool is reported in the accompanying basic financial statements at the amounts based upon the District's pro-rata share of the fair value provided by LAIF for the entire LAIF portfolio (in relation to the amortized cost of that portfolio). The balance available for withdrawal is based on the accounting records maintained by LAIF, which are recorded on an amortized cost basis.

The LAIF is a special fund of the California State Treasury through which local governments may pool investments. Each entity may invest up to \$75,000,000 in the fund. Investments in LAIF are highly liquid, as deposits can be converted to cash within twenty-four hours without loss of interest. Investments with LAIF are secured by the full faith and credit of the State of California.

**PLEASANT VALLEY RECREATION AND PARK DISTRICT**  
**NOTES TO BASIC FINANCIAL STATEMENTS**  
June 30, 2024

**NOTE 3 – CAPITAL ASSETS**

Capital assets activity for the fiscal year ended June 30, 2024, was as follows:

	<u>Balance</u> <u>July 1, 2023</u>	<u>Additions</u>	<u>Deletions /</u> <u>Transfers</u>	<u>Prior Period</u> <u>Adjustment</u>	<u>Balance</u> <u>June 30, 2024</u>
Non-depreciable capital assets					
Land	\$ 22,732,253	\$ -	\$ -	\$ -	\$ 22,732,253
Construction in progress	2,362,446	674,204	(1,450,771)	(915,751)	670,128
Total non-depreciable capital assets	<u>\$ 25,094,699</u>	<u>\$ 674,204</u>	<u>\$ (1,450,771)</u>	<u>\$ (915,751)</u>	<u>\$ 23,402,381</u>
Depreciable capital assets:					
PV Fields-Buildings	\$ 3,849,407	\$ -	\$ -	\$ -	\$ 3,849,407
PV Fields-Land grading	807,164				807,164
PV Fields-Land improvements	4,390,266				4,390,266
PV Fields-Lighting	2,271,285				2,271,285
PV Fields-Other assets	49,626				49,626
PV Fields-Playground equipment	86,177				86,177
PV Fields-Turf and landscaping	2,553,936				2,553,936
Freedom ball fields	516,963			781,955	1,298,918
Freedom ball fields lighting	225,128			133,796	358,924
Freedom ball fields land grading	305,852				305,852
Freedom ball fields turf & landscaping	518,363				518,363
Freedom ball fields land improvements	452,855				452,855
Land improvements	9,800,560	65,414	1,450,024		11,315,998
Assessment assets	128,560				128,560
Buildings, structures, and improvements	10,792,423	113,824	(32,559)		10,873,688
Furniture, fixtures, and office equipment	444,367	28,668			473,035
Machinery and heavy equipment	553,373	157,297			710,670
Playground equipment	1,560,891	59,893			1,620,784
Vehicles	511,271	28,960			540,231
Total depreciable capital assets	<u>\$ 39,818,467</u>	<u>\$ 454,056</u>	<u>\$ 1,417,465</u>	<u>\$ 915,751</u>	<u>\$ 42,605,739</u>

**PLEASANT VALLEY RECREATION AND PARK DISTRICT**  
**NOTES TO BASIC FINANCIAL STATEMENTS**  
June 30, 2024

**NOTE 3 – CAPITAL ASSETS (continued)**

	Balance July 1, 2023	Additions	Deletions	Prior Period Adjustment	Balance June 30, 2024
Accumulated depreciation:					
PV Fields-Buildings	\$ 1,324,262	\$ 98,703	\$ -	\$ -	\$ 1,422,965
PV Fields-Land grading	277,682	20,696			298,378
PV Fields-Land improvements	1,510,327	112,570			1,622,897
PV Fields-Lighting	781,360	58,239			839,599
PV Fields-Other assets	41,123	333			41,456
PV Fields-Playground equipment	77,079	5,746			82,825
PV Fields-Turf and landscaping	2,553,936				2,553,936
Freedom ball fields	271,404	64,946		136,842	473,192
Freedom ball fields lighting	118,189	17,946		23,414	159,549
Freedom ball fields land grading	160,575	15,292			175,867
Freedom ball fields turf & landscaping	272,139	25,919			298,058
Freedom ball fields land improvements	237,747	22,643			260,390
Land Improvements	7,949,181	183,407			8,132,588
Assessment assets	128,560				128,560
Buildings, structures, and improvements	6,863,338	271,741	(30,890)		7,104,189
Furniture, fixtures, and office equipment	382,085	13,932			396,017
Machinery and heavy equipment	465,484	12,025			477,509
Playground equipment	881,594	82,020			963,614
Vehicles	412,072	27,832			439,904
Total accumulated depreciation	<u>24,708,137</u>	<u>1,033,990</u>	<u>(30,890)</u>	<u>160,256</u>	<u>25,871,493</u>
Total depreciable capital assets, net	<u>\$ 15,110,330</u>	<u>\$ (579,934)</u>	<u>\$ 1,448,355</u>	<u>\$ 755,495</u>	<u>\$ 16,734,246</u>
Total capital assets, net	<u>\$ 40,205,029</u>	<u>\$ 94,270</u>	<u>\$ (2,416)</u>	<u>\$ (160,256)</u>	<u>\$ 40,136,627</u>

Depreciation expense for the fiscal year ended June 30, 2024, was \$1,033,990.

**NOTE 4 – CERTIFICATES OF PARTICIPATION – SERIES 2017**

On April 11, 2017, the District issued \$13,010,000 of refunding Certificates-of-Participation, with interest rates ranging from 2% to 5%. The proceeds were used to refund the 2009 certificates of \$12,130,000. The District had an accounting loss on the bond refunding of \$880,000 which is being amortized over the life of the 2009 issuance. The District realized an economic gain of \$644,446 on the refunding.

The certificates mature November 1, 2045, as follows:

Fiscal Year Ending June 30,	Principal	Interest	Total
2025	\$ 340,000	\$ 413,519	\$ 753,519
2026	350,000	403,418	753,418
2027	360,000	392,768	752,768
2028	375,000	377,993	752,993
2029	390,000	362,768	752,768
2030-2034	2,155,000	1,612,453	3,767,453
2035-2039	2,575,000	1,175,906	3,750,906
2040-2044	3,125,000	608,500	3,733,500
2045-2046	1,430,000	57,800	1,487,800
Total	<u>\$11,100,000</u>	<u>\$ 5,405,125</u>	<u>\$16,505,125</u>

**NOTE 5 – OTHER POSTEMPLOYMENT BENEFITS PAYABLE OTHER THAN PENSIONS**

Plan Description

The District pays a portion of the cost of health insurance for retirees under any group plan offered by CalPERS, subject to certain restrictions as determined by the District. The District offers post-employment medical benefits to retired employees who satisfy the eligibility rules (5-years of service). Dependents are also eligible to receive benefits. Retirees may enroll in any plan available through the District's CalPERS medical program. The contribution requirements of Plan members and the District are established and may be amended by the Board of Directors. The District will reimburse the retiree for retiree and/or retiree's dependent health insurance premiums (medical) up to a maximum of \$128 per month. At June 30, 2024, there were forty active employees, with eight retirees currently receiving benefits.

Funding Policy

The District accounts for this benefit on a pay-as-you-go basis. Postemployment expenditures are made from the General Fund, which is maintained on the modified accrual basis of accounting. For the fiscal year ended June 30, 2024, the District paid \$17,539 in contributions. No assets are accumulated in a trust that meets the criteria in Paragraph 4 of GASB Statement No. 75.

Employees Covered

As of the July 1, 2023 actuarial valuation, the following current and former employees were covered by the benefit terms under the District's plan:

Active plan members	40
Inactive plan members of beneficiaries currently receiving benefits	8
	48

OPEB Liability

The District's OPEB Liability was measured as of June 30, 2023 and the total OPEB liability used to calculate the net OPEB Liability was determined by an actuarial valuation as of July 1, 2023.

*Actuarial assumptions.* The total OPEB liability was determined using the following actuarial assumptions, applied to all periods included in the measurement, unless otherwise specified:

Inflation rate	2.30%
Salary increases	2.80%
Healthcare cost trend rate	5.50% for 2023 - 2034, 4.50% for 2035 - 2074, and 4.00% for 2075 and future years

Pre-retirement and post-retirement mortality rates used in this valuation are those used in the most recent CalPERS' valuations.

*Discount rate.* GASB Statement No. 75 requires a discount rate that reflects the following:

- a) The long-term expected rate of return on OPEB plan investments to the extent that the OPEB plan's fiduciary net position (if any) is projected to be sufficient to make projected benefit payments and assets are expected to be invested using a strategy to achieve that return;
- b) A yield or index for 20-year, tax-exempt general obligation municipal bonds with an average rating of AA/Aa or higher-to the extent that the conditions in (a) are not met.

To determine a resulting single (blended) rate, the amount of the plan's fiduciary net position (if any) and the amount of projected benefit payments is compared to each period of projected benefit payments. The discount rate used to measure the District's total OPEB liability is based on these requirements and the information on the following page:

PLEASANT VALLEY RECREATION AND PARK DISTRICT  
 NOTES TO BASIC FINANCIAL STATEMENTS  
 June 30, 2024

**NOTE 5 – OTHER POSTEMPLOYMENT BENEFITS PAYABLE OTHER THAN PENSIONS (continued)**

OPEB Liability (Continued)

Reporting Date	Measurement Date	Long-Term Expected Return of Plan Investments Rate Index	Municipal Bond 20 Year High Grade Discount Rate
June 30, 2024	June 30, 2023	3.86%	3.86%
June 30, 2023	June 30, 2022	3.69%	3.69%

*Change in Assumptions:* The discount rate used to calculate OPEB liability was changed from 3.69% to 3.86% from the measurement period ending June 30, 2022 to the measurement period ending June 30, 2023.

	Total OPEB Liability
Balance at June 30, 2023 (Valuation Date July 1, 2023)	\$ 859,183
Changes recognized for the measurement period:	
Service cost	33,792
Interest cost	32,587
Difference between expected and actual experience	(289,018)
Changes of assumptions	(46,421)
Benefit payments	(19,915)
Net Changes	(288,975)
Balance at June 30, 2024 (Measurement Date June 30, 2023)	\$ 570,208

Changes in the OPEB Liability

*Sensitivity of the OPEB liability to changes in the discount rate.* The following presents the total OPEB liability, as well as what the net OPEB liability would be if it were calculated using a discount rate that is 1 percentage-point lower (2.86%) or 1 percentage point higher (4.86%) than the current discount rate:

	1% Decrease (2.86%)	Discount Rate (3.86%)	1% Increase (4.86%)
Total OPEB Liability	\$ 656,281	\$ 570,208	\$ 498,782

*Sensitivity of the OPEB liability to changes in the healthcare cost trend rates.* The following presents the total OPEB liability, as well as what the OPEB liability would be if it were calculated using healthcare cost trend rates that are 1 percentage-point lower or 1 percentage-point higher than the current healthcare cost trend rates:

	1% Decrease (4.50% Decreasing to 3.00%)	Trend Rate (5.50% Decreasing to 4.00%)	1% Increase (6.50% Decreasing to 5.00%)
Total OPEB Liability	\$ 482,484	\$ 570,208	\$ 498,782

**PLEASANT VALLEY RECREATION AND PARK DISTRICT**  
**NOTES TO BASIC FINANCIAL STATEMENTS**  
 June 30, 2024

---

**NOTE 5 – OTHER POSTEMPLOYMENT BENEFITS PAYABLE OTHER THAN PENSIONS (continued)**

OPEB Expense and Deferred Outflows/Inflows of Resources Related to OPEB

For the fiscal year ended June 30, 2024, the District recognized OPEB expense of \$11,510. As of the fiscal year ended June 30, 2024, the District reported deferred outflows and deferred inflows of resources related to OPEB from the following sources:

	<u>Deferred Outflows of Resources</u>	<u>Deferred Inflows of Resources</u>
OPEB contributions subsequent to measurement date	\$ 17,539	\$ -
Difference between expected and actual experience	248	402,508
Change in assumptions	180,811	353,168
	<u>\$ 198,598</u>	<u>\$ 755,676</u>

Deferred outflows of resources and deferred inflows of resources above represent the unamortized portion of changes to OPEB liability to be recognized in future periods in a systematic and rational manner. \$17,539 reported as deferred outflows of resources related to OPEB resulting from District contributions subsequent to the measurement date will be recognized as a reduction of the OPEB liability in the fiscal year ended June 30, 2025.

Amounts reported as deferred outflows and deferred inflows of resources will be recognized in OPEB expense as follows on the following page:

<u>Fiscal year ending June 30,</u>	<u>Amount</u>
2025	\$ (54,869)
2026	(54,869)
2027	(48,079)
2028	(39,117)
2029	(36,566)
Thereafter	(341,117)
	<u>\$ (574,617)</u>

**NOTE 6 – PENSION PLAN**

**A. General Information about the Pension Plans**

*Plan Descriptions*

All qualified permanent and probationary employees are eligible to participate in the District’s Miscellaneous Employee Pension Plans, cost-sharing multiple employer defined benefit plans administered by the California Public Employees’ Retirement System (CalPERS). Benefit provisions under the Plans are established by State statute and District resolution. CalPERS issues publicly available reports that include a full description of the pension plans regarding benefit provisions, assumptions and membership information that can be found on the CalPERS’ website.

*Benefits Provided*

CalPERS provides service retirement and disability benefits, annual cost of living adjustments and death benefits to plan members, who must be public employees and beneficiaries. Benefits are based on years of credited service, equal to one year of full-time employment. Members with five years of total service are eligible to retire at age 50 with statutorily reduced benefits. All members are eligible for nonduty disability benefits after 10 years of service. The death benefit is one of the following: the Basic Death Benefit, the 1957 Survivor Benefit, or the Optional Settlement 2W Death Benefit. The cost of living adjustments for each plan are applied as specified by the Public Employees’ Retirement Law.

**PLEASANT VALLEY RECREATION AND PARK DISTRICT**  
**NOTES TO BASIC FINANCIAL STATEMENTS**  
June 30, 2024

**NOTE 6 – PENSION PLAN (continued)**

**A. General Information about the Pension Plans (Continued)**

The Plans' provisions and benefits in effect at June 30, 2024, are summarized as follows:

	Miscellaneous		
	Prior to March 12, 2011	March 12, 2011 through December 31, 2012	On or after January 1, 2013
Hire Date			
Benefit formula	2.5% @ 55	2% @ 60	2% @ 62
Benefit vesting schedule	5 years service	5 years service	5 years service
Benefit payments	monthly for life	monthly for life	monthly for life
Retirement age	50-63	50-65	52-67
Monthly benefits, as a % of eligible compensation	1.426% to 2.418%	1.0% to 2.5%	1.0% to 2.5%
Required employee contribution rates	8.00%	7.00%	7.75%
Required employer contribution rates	13.34% + \$511,307	10.10% + \$0	7.68% + \$0

*Contributions*

Section 20814(c) of the California Public Employees' Retirement Law requires that the employer contribution rates for all public employers be determined on an annual basis by the actuary and shall be effective on the July 1 following notice of a change in the rate. Funding contributions for the Plan are determined annually on an actuarial basis as of June 30 by CalPERS. The actuarially determined rate is the estimated amount necessary to finance the costs of benefits earned by employees during the year, with an additional amount to finance any unfunded accrued liability. The District is required to contribute the difference between the actuarially determined rate and the contribution rate of employees. Contributions to the pension plan from the District were \$1,203,951 for the fiscal year ended June 30, 2024.

**B. Pension Liabilities, Pension Expenses, and Deferred Outflows/Inflows of Resources Related to Pensions**

At June 30, 2024, the District reported a liability of \$6,947,999 for its proportionate share of the net pension liability. The net pension liability was measured as of June 30, 2023 and the total pension liability used to calculate the net pension liability was determined by an actuarial valuation as of June 30, 2022 rolled forward to June 30, 2023 using standard roll-forward procedures. The District's proportion of the net pension liability was based on a projection of the District's long-term share of contributions to the pension plan relative to the projected contributions of all Pension Plan participants, actuarially determined. At June 30, 2023, the District's proportion was 0.14859% and at June 30, 2022 the District's proportion was 0.13895%, a decrease of 0.00964%.

For the fiscal year ended June 30, 2024, the District recognized pension expense of \$992,387. Pension expense represents the change in the net pension liability during the measurement period, adjusted for actual contributions and the deferred recognition of changes in investment gain/loss, actuarial gain/loss, actuarial assumptions or method, and plan benefits. At June 30, 2024, the District reported deferred outflows of resources and deferred inflows of resources related to pensions from the following sources:

	Deferred Outflows of Resources	Deferred Inflows of Resources
Differences between expected and actual experience	\$ 354,941	\$ 55,060
Changes in assumptions	419,482	
Net difference between projected and actual earnings on retirement plan investments	1,124,944	
Changes in proportion and differences between District contributions and proportionate share of contributions	285,242	86,274
Adjustment due to differences in proportion	91,327	506,622
District contributions subsequent to the measurement date	1,203,951	
	<u>\$ 3,479,887</u>	<u>\$ 647,956</u>



PLEASANT VALLEY RECREATION AND PARK DISTRICT  
 NOTES TO BASIC FINANCIAL STATEMENTS  
 June 30, 2024

**NOTE 6 – PENSION PLAN (continued)**

**B. Pension Liabilities, Pension Expenses, and Deferred Outflows/Inflows of Resources Related to Pensions (Continued)**

Deferred outflows of resources and deferred inflows of resources above represent the unamortized portion of changes to net pension liability to be recognized in future periods in a systematic and rational manner. \$1,203,951 reported as deferred outflows of resources related to pensions resulting from District contributions subsequent to the measurement date will be recognized as a reduction of the net pension liability in the fiscal year ended June 30, 2025.

Other amounts reported as deferred outflows of resources and deferred inflows of resources related to pensions will be recognized in the pension expense as follows:

<u>Fiscal Year Ending June 30,</u>	<u>Amount</u>
2025	\$ 467,646
2026	260,249
2027	867,806
2028	32,279
	<u>\$ 1,627,980</u>

*Actuarial Assumptions*

The total pension liability in the July 1, 2023 actuarial valuation was determined using the following actuarial assumptions:

	<u>Miscellaneous</u>
Valuation Date	June 30, 2022
Measurement Date	June 30, 2023
Actuarial Cost Method	Entry-Age Actuarial Cost Method
Actuarial Assumptions:	
Discount Rate	6.90%
Inflation	2.30%
Salary Increases	Varies by Entry Age and Service
Mortality	Derived using CalPERS' Membership Data for all Funds (1)
Post Retirement Benefit Increase	The lesser of contract COLA or 2.30% until Purchasing Power Protection Allowance floor on purchasing power applies, 2.30% thereafter

(1) The mortality table used was developed based on CalPERS' specific data. The probabilities are based on the 2021 CalPERS' Experience Study for the period from 2001 to 2019. Pre-retirement and Post-retirement mortality rates include generational mortality improvement using 80% of Scale MP-2020 published by the Society of Actuaries. For more details on this table, please refer to the CalPERS' Experience Study and Review of Actuarial

*Long-term Expected Rate of Return*

In determining the long-term expected rate of return, CalPERS took into account long-term market return expectations as well as the expected pension fund cash flows. Projected returns for all asset classes are estimated and combined with risk estimates, are used to project compound (geometric) returns over the long term. The discount rate used to discount liabilities was informed by the long-term projected portfolio return. The expected real rates of return by asset class are as shown on the following page:

**PLEASANT VALLEY RECREATION AND PARK DISTRICT**  
**NOTES TO BASIC FINANCIAL STATEMENTS**  
 June 30, 2024

**NOTE 6 – PENSION PLAN (continued)**

**B. Pension Liabilities, Pension Expenses, and Deferred Outflows/Inflows of Resources Related to Pensions (Continued)**

*Long-term Expected Rate of Return (Continued)*

Asset Class	New Strategic Allocation	Real Return (a,b)
Global Equity - cap-weighted	30.0%	4.54%
Global Equity - non-cap-weighted	12.0%	3.84%
Private Equity	13.0%	7.28%
Treasury	5.0%	0.27%
Mortgage-backed Securities	5.0%	0.50%
Investment Grade Corporations	10.0%	1.56%
High Yield	5.0%	2.27%
Emerging Market Debt	5.0%	2.48%
Private Debt	5.0%	3.57%
Real Assets	15.0%	3.21%
Leverage	-5.0%	-0.59%
Total	<u>100.0%</u>	

(a) An expected inflation of 2.30% was used for this period.

(b) Figures are based on the 2021 Asset Liability Management Study.

*Discount Rate*

The discount rate used to measure the total pension liability was 6.90%. The projection of cash flows used to determine the discount rate assumed that contributions from plan members will be made at the current member contribution rates and that contributions from employers will be made at statutorily required rates, actuarially determined. Based on those assumptions, the Plan’s fiduciary net position was projected to be available to make all projected future benefit payments of current plan members. Therefore, the long-term expected rate of return on plan investments was applied to all periods of projected benefit payments to determine the total pension liability.

*Sensitivity of the Proportionate Share of the Net Pension Liability to Changes in Discount Rate*

The following represents the District’s proportionate share of the net pension liability calculated using the discount rate of 6.90 percent, as well as what the District’s proportionate share of the net pension liability would be if it were calculated using a discount rate that is 1 percentage point lower (5.90 percent) or 1 percentage point higher (7.90 percent) than the current rate:

	1% Decrease <u>5.90%</u>	Discount Rate <u>6.90%</u>	1% Increase <u>7.90%</u>
District's proportionate share of the net pension plan liability	\$ 10,224,342	\$ 6,947,999	\$ 4,251,287

*Pension Plan Fiduciary Net Position*

Detailed information about the pension plan’s fiduciary net position is available in the separately issued CalPERS’ financial reports.

**C. Payable to Pension Plan**

At June 30, 2024, the District had no amount outstanding for contributions to the pension plan required for the fiscal year ended June 30, 2024.

**PLEASANT VALLEY RECREATION AND PARK DISTRICT**  
**NOTES TO BASIC FINANCIAL STATEMENTS**  
 June 30, 2024

**NOTE 7 – LONG-TERM LIABILITIES**

The following is a summary of long-term liabilities for the fiscal year ended June 30, 2024:

	Balance July 1, 2023	Increases	Decreases	Balance June 30, 2024	Due within One year
Compensated absences	\$ 471,807	\$ 100,418	\$ (143,743)	\$ 428,482	\$ 42,848
2017 Certificates of participation	11,425,000		(325,000)	11,100,000	340,000
Certificates of participation premium	59,460		(2,854)	56,606	2,854
Other post employment benefits	859,183		(288,975)	570,208	
Net pension liability	6,952,796		(4,797)	6,947,999	
Total	<u>\$ 19,768,246</u>	<u>\$ 100,418</u>	<u>\$ (765,369)</u>	<u>\$19,103,295</u>	<u>\$ 385,702</u>

**NOTE 8 – DEFERRED COMPENSATION SAVINGS PLAN – FULL-TIME EMPLOYEES**

For the benefit of its employees, the District participates in two 457 Deferred Compensation Programs (Programs). The purpose of these Programs is to provide deferred compensation for public employees that elect to participate in the Programs. Generally, eligible employees may defer receipt of a portion of their salary until termination, retirement, death, or unforeseeable emergency.

Federal law requires deferred compensation assets to be held in trust for the exclusive benefit of the participants. Accordingly, the District is in compliance with this legislation. Therefore, these assets are not the legal property of the District and are not subject to claims of the District's general creditors. Fair value of the plan assets held in trust by ICMA Retirement Corporation and MetLife at June 30, 2024 was \$1,448,203 and \$200,645 respectively.

The District has implemented GASB Statement No. 32, *Accounting and Financial Reporting for Internal Revenue Code Section 457 Deferred Compensation Plans*. Since the District has little administrative involvement and does not perform the investing function for this plan, the assets and related liabilities are not shown on the statement of net position.

**NOTE 9 – DEFERRED COMPENSATION SAVINGS PLAN – PART-TIME EMPLOYEES**

Part-time employees are covered by a deferred compensation plan in accordance with Internal Revenue Code Section 457 (Plan). The Plan is a non-elective deferred compensation arrangement for the benefit of employees who are not covered by another retirement system maintained by the District. Under the Plan, an eligible Participant accrues a monthly benefit that is equal to one-twelfth (1/12) of an amount equal to 2% of the Participant's average annual compensation times years of service up to 30 years. Distributions from the Plan are made only when the Participant has separated from service and the Participant's accrued benefits are non-forfeitable.

With certain limitations, a Participant may elect the time and manner by which his or her deferred amounts will be distributed. The election must be made prior to the date any such amounts become payable to the Participant. If the Participant fails to make a timely election concerning distribution of the deferred amounts, the amounts shall be in a lump sum distribution as prescribed by the Plan. The manner and time of benefit payout must meet the distribution requirements of the Internal Revenue Code Section 401(a) and 457(d)(2).

The Plan provides that all amounts deferred under the Plan, all property and rights purchased with such amounts, and all income attributable to such amounts, or rights will remain (until made available to the participant) solely the property and rights of the District, subject only to claims of such District's general creditors. The rights of any Participant or beneficiary to payments pursuant to the Plan are non-assignable, and his or her interest in benefits under the Plan is not subject to attachment, garnishment or other legal process. Currently, one retired employee is receiving monthly benefit check from this Plan and three retired employees are receiving an annual benefit.

In 2011, the assets of the Plan were transferred to the Part-Time Employees Retirement Trust Fund, with the District remaining the trustee of the Plan, and held as a fiduciary fund of the District in the accompanying financial statements.

**NOTE 10 – DEFERRED OUTFLOWS OF RESOURCES-REFUNDING OF DEBT**

At June 30, 2024, deferred outflows of resources, reported in the statement of net position relating to the defeasance of the 2009 certificates of participation, consisted of the following:

	Governmental Activities
Deferred charge on debt refunding	<u>\$ 444,056</u>

**NOTE 11 – LEASE RECEIVABLE**

In March 2003, the District entered into a 40 year lease with New Cingular Wireless PCS, LLC to lease property at 5901 Mission Oaks Blvd, Camarillo. An initial lease receivable of \$215,346 was recorded. The lessee is required to make monthly payments of \$1,734 as of June 30, 2024 that increase by CPI but no more than 3% annually. The lease was valued with the City’s incremental borrowing rate at the time of 3.0%.

In August 2006, the District entered into a 30 year lease with New Cingular Wireless PCS, LLC to lease property at 1030 Temple Ave, Camarillo. An initial lease receivable of \$1,153,739 was recorded. The lessee is required to make monthly payments of \$3,927 as of June 30, 2024 that increase by the greater of CPI or 4% annually. On August 1, 2026 the monthly payment will reset to \$4,200 and increase annually by CPI but no more than 8% and no less than 4%. The lease was valued with the City’s incremental borrowing rate at the time of 3.0%.

In May 2009, the District entered into a 20 year lease with T-Mobile USA, Inc to lease property at 5501 Mission Oaks Blvd, Camarillo. An initial lease receivable of \$288,829 was recorded. The lessee is required to make monthly payments of \$3,595 as of June 30, 2024 that increase by CPI or 4% annually, whichever is greater. The lease was valued with the City’s incremental borrowing rate at the time of 3.0%.

In March 2023, the District entered into a 30 year lease with DISH Wireless, LLC to lease property at 5501 Mission Oaks Blvd, Camarillo. An initial lease receivable of \$1,553,437 was recorded. The lessee is required to make monthly payments of \$3,800 as of June 30, 2024 that increase by CPI or 4% annually, whichever is greater. The lease was valued with the City’s incremental borrowing rate at the time of 3.0%.

**NOTE 12 – RISK MANAGEMENT**

The District is a member of the Park and Recreation District Employee Compensation with the California Association for Park and Recreation Insurance (CAPRI).

**A. Description of CAPRI**

CAPRI is comprised of 63 members and is organized under a Joint Exercise Powers Agreement pursuant to the California Government Code. The purpose of the CAPRI is to arrange and administer programs of insurance, risk management, and loss prevention for the pooling of self-insured losses and to purchase excess insurance coverage. CAPRI is governed by a separate board of directors, which is comprised of seven directors elected from the member districts. The board controls the operations of CAPRI, including selection of management and approval of operating budgets.

**B. Self-Insurance Programs of CAPRI**

General and auto liability, public officials and employees' liability programs have total risk financing insurance limits of \$1,000,000 with various deductibles of \$2,000 to \$20,000 per occurrence. Excess insurance has been purchased by the District above the self-insurance limits. In addition to the above, the District also has the following insurance coverage:

- All-Risks property loss coverage including boiler and machinery coverage, is subject to a \$2,000 deductible per occurrence payable by the District.
- Flood and earthquake coverage with an annual aggregate limit of \$5,000,000 per occurrence for earthquakes and \$10,000,000 for flood for all member districts. The deductible for all loss or damage arising from the risks of flood is \$20,000 and/or earthquake is \$50,000 per occurrence or 5% of the value of the building, contents and/or structure, whichever is greater.
- Workers' compensation insurance up \$350,000 limits.

**NOTE 12 – RISK MANAGEMENT**

**B. Self-Insurance Programs of CAPRI (Continued)**

Settled claims have not exceeded any of the coverage amounts in any of the last three fiscal years and there were no reductions in the District's insurance coverage during the years ending June 30, 2024 and 2023. Liabilities are recorded when it is probable that a loss has been incurred and the amount of the loss can be reasonably estimated net of the respective insurance coverage. Liabilities include an amount for claims that have been incurred but not reported (IBNR). There were no IBNR claims payable as of June 30, 2024 and 2023.

**NOTE 13 – CONTINGENCIES**

Litigation

In the ordinary course of operations, the District is subject to other claims and litigation from outside parties. After consultation with legal counsel, the District believes the ultimate outcome of such matters will not materially affect its financial condition.

Construction

The District had outstanding construction commitments as of June 30, 2024 on the following projects:

Pickleball Complex	\$ 62,373
Senior Center Enhancements	20,009
Lokker Park Playground	9,582

**NOTE 14 – PRIOR PERIOD ADJUSTMENT**

A prior period adjustment of (\$169,014) was made to the Statement of Activities. This consisted of an adjustment of (\$160,256) for depreciation on the Freedom Ball Fields and Lighting project that was completed in December 2019 but was not moved from construction in progress to depreciable asset and an adjustment of (\$8,758) was made to the statement of activities and to the Quimby Fund to remove an old interest receivable balance that was received in past fiscal years.

**THIS PAGE IS INTENTIONALLY LEFT BLANK**

**REQUIRED SUPPLEMENTARY INFORMATION**





PLEASANT VALLEY RECREATION AND PARK DISTRICT

GENERAL FUND

SCHEDULE OF REVENUES, EXPENDITURES, AND CHANGES IN FUND BALANCE - BUDGET AND ACTUAL

For Fiscal Year Ended June 30, 2024

	General Fund			Variance with Final Budget Positive (Negative)
	Budgeted Amounts		Actual	
	Original	Final		
<b>Revenues</b>				
Property taxes	\$ 8,109,714	\$ 8,109,714	\$ 8,827,361	\$ 717,647
Charges for services:				
Registration and other fees	737,453	750,553	915,911	165,358
Facility and other rental fees	711,843	711,843	687,230	(24,613)
Operating grants and contributions	2,500	8,315	36,765	28,450
Capital grants and contributions			62,001	62,001
Investment earnings	231,000	301,000	646,802	345,802
Other revenues	386,950	386,950	848,227	461,277
Total revenues	<u>10,179,460</u>	<u>10,268,375</u>	<u>12,024,297</u>	<u>1,755,922</u>
<b>Expenditures</b>				
Current:				
Salaries and benefits	5,153,694	5,172,484	5,185,445	(12,961)
Materials and services	3,771,175	3,785,239	3,670,690	114,549
Capital outlay	1,115,000	1,384,776	940,446	444,330
Debt service:				
Interest	343,214	343,214	341,040	2,174
Total expenditures	<u>10,383,083</u>	<u>10,685,713</u>	<u>10,137,621</u>	<u>548,092</u>
Net change in fund balance	(203,623)	(417,338)	1,886,676	2,304,014
Fund balances - beginning of fiscal year	10,954,557	10,954,557	10,954,557	
Fund balance - end of fiscal year	<u>\$ 10,750,934</u>	<u>\$ 10,537,219</u>	<u>\$ 12,841,233</u>	<u>\$ 2,304,014</u>

PLEASANT VALLEY RECREATION AND PARK DISTRICT  
SPECIAL REVENUE FUND - ASSESSMENT DISTRICT FUND  
SCHEDULE OF REVENUES, EXPENDITURES, AND CHANGES IN FUND BALANCE - BUDGET AND ACTUAL  
For Fiscal Year Ended June 30, 2024

	Assessment District Fund			Variance with Final Budget Positive (Negative)
	Budgeted Amounts		Actual	
	Original	Final		
<b>Revenues</b>				
Charges for services:				
Special assessments	\$ 1,293,871	\$ 1,293,871	\$ 1,313,352	\$ 19,481
Investment earnings	20,000	20,000	51,943	31,943
Total revenues	<u>1,313,871</u>	<u>1,313,871</u>	<u>1,365,295</u>	<u>51,424</u>
<b>Expenditures</b>				
Current:				
Salaries and benefits		81,519	81,519	
Materials and services	892,088	802,020	681,015	121,005
Debt service:				
Principal	325,000	325,000	325,000	
Interest	83,780	83,780	83,780	
Total expenditures	<u>1,300,868</u>	<u>1,292,319</u>	<u>1,171,314</u>	<u>121,005</u>
Net change in fund balance	13,003	21,552	193,981	172,429
Fund balance - beginning of fiscal year	<u>1,131,049</u>	<u>1,131,049</u>	<u>1,131,049</u>	
Fund balance - end of fiscal year	<u>\$ 1,144,052</u>	<u>\$ 1,152,601</u>	<u>\$ 1,325,030</u>	<u>\$ 172,429</u>

PLEASANT VALLEY RECREATION AND PARK DISTRICT  
SPECIAL REVENUE FUND - QUIMBY FUND  
SCHEDULE OF REVENUES, EXPENDITURES, AND CHANGES IN FUND BALANCE - BUDGET AND ACTUAL  
For Fiscal Year Ended June 30, 2024

	Quimby Fund			Variance with Final Budget Positive (Negative)
	Budgeted Amounts		Actual	
	Original	Final		
<b>Revenues</b>				
Investment earnings	\$ 120,000	\$ 120,000	\$ 397,596	\$ 277,596
Total revenues	<u>120,000</u>	<u>120,000</u>	<u>397,596</u>	<u>277,596</u>
<b>Expenditures</b>				
Capital outlay	2,921,769	2,921,769	202,276	2,719,493
Total expenditures	<u>2,921,769</u>	<u>2,921,769</u>	<u>202,276</u>	<u>2,719,493</u>
Net change in fund balance	<u>(2,801,769)</u>	<u>(2,801,769)</u>	<u>195,320</u>	<u>2,997,089</u>
Fund balance - beginning of fiscal year	7,035,182	7,035,182	7,035,182	
Prior-period adjustments			(8,758)	
Fund balances - beginning of fiscal year, restated	<u>7,035,182</u>	<u>7,035,182</u>	<u>7,026,424</u>	
Fund balance - end of fiscal year	<u>\$ 4,233,413</u>	<u>\$ 4,233,413</u>	<u>\$ 7,221,744</u>	<u>\$ 2,997,089</u>

**PLEASANT VALLEY RECREATION AND PARK DISTRICT**  
**SCHEDULE OF CHANGES IN THE OPEB LIABILITY AND RELATED RATIOS**  
Last 10 Years\*  
FOR THE FISCAL YEAR ENDED JUNE 30, 2024

Reporting Period	<u>2024</u>	<u>2023</u>	<u>2022</u>	<u>2021</u>
<b>Total OPEB liability</b>				
Service cost	\$ 33,792	\$ 81,083	\$ 80,062	\$ 37,974
Interest on the total OPEB liability	32,587	21,394	26,119	30,962
Actual and expected experience difference	(289,018)		(93,737)	380
Changes in assumptions	(46,421)	(261,028)	(50,517)	216,690
Benefit payments	(19,915)	(30,798)	(30,193)	(31,425)
<b>Net change in total OPEB liability</b>	<b>\$ (288,975)</b>	<b>\$ (189,349)</b>	<b>\$ (68,266)</b>	<b>\$ 254,581</b>
Total OPEB liability-beginning	859,183	1,048,532	1,116,798	862,217
Total OPEB liability-ending	<u>\$ 570,208</u>	<u>\$ 859,183</u>	<u>\$ 1,048,532</u>	<u>\$ 1,116,798</u>
Covered Payroll	\$ 2,784,872	\$ 2,283,496	\$ 2,346,838	\$ 2,386,027
Total OPEB Liability as a percentage of covered payroll	20.48%	37.63%	44.68%	46.81%
Reporting Period	<u>2020</u>	<u>2019</u>	<u>2018</u>	
<b>Total OPEB liability</b>				
Service cost	\$ 31,909	\$ 32,780	\$ 37,677	
Interest on the total OPEB liability	33,481	31,031	26,847	
Actual and expected experience difference	(100,820)		(15,167)	
Changes in assumptions	71,218	(51,070)	(107,163)	
Benefit payments	(13,465)	(13,532)	(11,571)	
<b>Net change in total OPEB liability</b>	<b>\$ 22,323</b>	<b>\$ (791)</b>	<b>(69,377)</b>	
Total OPEB liability-beginning	839,894	840,685	910,062	
Total OPEB liability-ending	<u>862,217</u>	<u>839,894</u>	<u>\$ 840,685</u>	
Covered Payroll	\$ 2,356,224	\$ 2,474,831	\$ 2,491,745	
Total OPEB Liability as a percentage of covered payroll	36.59%	33.94%	33.74%	

**Notes to Schedule:**

The discount rate was changed from 3.69% to 3.86% for the June 30, 2023 measurement date.

\*-Fiscal year 2018 was the first year of implementation, therefore only seven years are shown.

**PLEASANT VALLEY RECREATION AND PARK DISTRICT**  
**SCHEDULE OF OPEB CONTRIBUTIONS**  
**FOR THE FISCAL YEAR ENDED JUNE 30, 2024**

---

The District's contributions for the fiscal year ended June 30, 2024 was \$17,539. The District did not have an actuary calculate the Actuarially Determined Contribution for the fiscal year ended June 30, 2024, therefore, the District does not need to comply with the GASB Statement No. 75's Required Supplementary Information requirements.

The District's contributions for the fiscal year ended June 30, 2023 was \$16,166. The District did not have an actuary calculate the Actuarially Determined Contribution for the fiscal year ended June 30, 2023, therefore, the District does not need to comply with the GASB Statement No. 75's Required Supplementary Information requirements.

The District's contributions for the fiscal year ended June 30, 2022 was \$16,790. The District did not have an actuary calculate the Actuarially Determined Contribution for the fiscal year ended June 30, 2022, therefore, the District does not need to comply with the GASB Statement No. 75's Required Supplementary Information requirements.

The District's contributions for the fiscal year ended June 30, 2021 was \$30,193. The District did not have an actuary calculate the Actuarially Determined Contribution for the fiscal year ended June 30, 2021, therefore, the District does not need to comply with the GASB Statement No. 75's Required Supplementary Information requirements.

The District's contributions for the fiscal year ended June 30, 2020 was \$31,425. The District did not have an actuary calculate the Actuarially Determined Contribution for the fiscal year ended June 30, 2020, therefore, the District does not need to comply with the GASB Statement No. 75's Required Supplementary Information requirements.

The District's contributions for the fiscal year ended June 30, 2019 was \$13,465. The District did not have an actuary calculate the Actuarially Determined Contribution for the fiscal year ended June 30, 2019, therefore, the District does not need to comply with the GASB Statement No. 75's Required Supplementary Information requirements.

The District's contributions for the fiscal year ended June 30, 2018 was \$13,532. The District did not have an actuary calculate the Actuarially Determined Contribution for the fiscal year ended June 30, 2018, therefore, the District does not need to comply with the GASB Statement No. 75's Required Supplementary Information requirements.

**PLEASANT VALLEY RECREATION AND PARK DISTRICT**  
**SCHEDULE OF PROPORTIONATE SHARE OF NET PENSION LIABILITY**  
 Last 10 Years  
 As of June 30, 2024

The following table provides required supplementary information regarding the District's Pension Plan.

	<u>2024</u>	<u>2023</u>	<u>2022</u>	<u>2021</u>	<u>2020</u>
Proportion of the net pension liability	0.05569%	0.06019%	0.07113%	0.04956%	0.05503%
Proportionate share of the net pension liability	\$ 6,947,999	\$ 6,952,796	\$ 3,846,728	\$ 5,392,757	\$ 5,638,791
Covered payroll	\$ 2,737,372	\$ 2,272,644	\$ 2,304,893	\$ 2,311,561	\$ 2,397,349
Proportionate share of the net pension liability as percentage of covered payroll	253.82%	305.93%	166.89%	233.30%	235.21%
Plan's total pension liability	\$ 52,441,984,274	\$ 49,525,975,138	\$ 46,174,942,264	\$ 43,702,930,887	\$ 41,426,453,489
Plan's fiduciary net position	\$ 39,966,633,692	\$ 37,975,170,163	\$ 40,766,653,876	\$ 32,822,501,335	\$ 31,179,414,067
Plan fiduciary net position as a percentage of the total pension liability	76.21%	76.68%	88.29%	75.10%	75.26%
	<u>2019</u>	<u>2018</u>	<u>2017</u>	<u>2016</u>	<u>2015</u>
Proportion of the net pension liability	0.05442%	0.04712%	0.05434%	0.05172%	0.04365%
Proportionate share of the net pension liability	\$ 5,244,080	\$ 4,673,053	\$ 4,701,684	\$ 3,550,158	\$ 2,715,962
Covered payroll	\$ 2,491,745	\$ 2,333,876	\$ 2,100,839	\$ 2,058,236	\$ 2,127,640
Proportionate share of the net pension liability as percentage of covered payroll	210.46%	200.23%	223.80%	172.49%	127.65%
Plan's total pension liability	\$ 38,944,855,364	\$ 37,161,348,332	\$ 33,358,627,624	\$ 31,771,217,402	\$ 30,829,966,631
Plan's fiduciary net position	\$ 29,308,589,559	\$ 27,244,095,376	\$ 24,705,532,291	\$ 24,907,305,871	\$ 24,607,502,515
Plan fiduciary net position as a percentage of the total pension liability	75.26%	73.31%	74.06%	78.40%	79.82%

**Notes to Schedule:**

There were no changes to assumptions for the fiscal year ended June 30, 2024.

**PLEASANT VALLEY RECREATION AND PARK DISTRICT**  
**SCHEDULE OF PENSION CONTRIBUTIONS**  
 Last 10 Years  
 As of June 30, 2024

The following table provides required supplementary information regarding the District's Pension Plan.

	2024	2023	2022	2021	2020
Contractually required contribution (actuarially determined)	\$ 792,396	\$ 755,354	\$ 713,551	\$ 656,136	\$ 553,145
Contribution in relation to the actuarially determined contributions	<u>(1,203,951)</u>	<u>(1,105,354)</u>	<u>(713,551)</u>	<u>(656,136)</u>	<u>(553,145)</u>
Contribution deficiency (excess)	<u>\$ (411,555)</u>	<u>\$ (350,000)</u>	<u>\$ -</u>	<u>\$ -</u>	<u>\$ -</u>
Covered payroll	\$ 2,651,330	\$ 2,737,372	\$ 2,272,644	\$ 2,304,893	\$ 2,311,561
Contributions as a percentage of covered payroll	45.41%	40.38%	31.40%	28.47%	23.93%
	2019	2018	2017	2016	2015
Contractually required contribution (actuarially determined)	\$ 365,356	\$ 367,229	\$ 364,537	\$ 347,493	\$ 273,584
Contribution in relation to the actuarially determined contributions	<u>(365,356)</u>	<u>(367,229)</u>	<u>(364,537)</u>	<u>(347,493)</u>	<u>(273,584)</u>
Contribution deficiency (excess)	<u>\$ -</u>	<u>\$ -</u>	<u>\$ -</u>	<u>\$ -</u>	<u>\$ -</u>
Covered payroll	\$ 2,397,349	\$ 2,491,745	\$ 2,333,876	\$ 2,100,839	\$ 2,058,236
Contributions as a percentage of covered payroll	15.24%	14.74%	15.62%	16.54%	13.29%

**Notes to Schedule:**

Changes in assumptions

In the reporting fiscal year ended June 30, 2024, the discount rate was reduced from 7.15% to 6.90% and price inflation was reduced from 2.50% to 2.30%.

**THIS PAGE IS INTENTIONALLY LEFT BLANK**



**SUPPLEMENTARY INFORMATION**



PLEASANT VALLEY RECREATION AND PARK DISTRICT  
NONMAJOR GOVERNMENTAL FUNDS  
COMBINING BALANCE SHEET  
June 30, 2024

	Special Revenue Funds		Total Nonmajor Special Revenue Funds
	Park Impact Fees Fund	CDBG Fund	
<b>ASSETS</b>			
Cash and investments	\$ 2,126,124	\$ (12,563)	\$ 2,113,561
Accounts receivable		12,563	12,563
Total assets	<u>\$ 2,126,124</u>	<u>\$ -</u>	<u>\$ 2,126,124</u>
<b>LIABILITIES AND FUND BALANCES</b>			
<b>Liabilities</b>			
Accounts payable and accrued expenditures	\$ -	\$ -	\$ -
Total liabilities	<u>\$ -</u>	<u>\$ -</u>	<u>\$ -</u>
<b>Fund Balances</b>			
Restricted:			
Specified park projects	2,126,124		2,126,124
Total fund balances	<u>2,126,124</u>		<u>2,126,124</u>
Total liabilities and fund balances	<u>\$ 2,126,124</u>	<u>\$ -</u>	<u>\$ 2,126,124</u>

**PLEASANT VALLEY RECREATION AND PARK DISTRICT**  
**NONMAJOR GOVERNMENTAL FUNDS**  
**COMBINING STATEMENT OF REVENUES, EXPENDITURES, AND CHANGES IN FUND BALANCES**  
**FISCAL YEAR ENDED JUNE 30, 2024**

	<u>Special Revenue Funds</u>		Total Nonmajor Special Revenue Funds
	<u>Park Impact Fees Fund</u>	<u>CDBG Fund</u>	
<b>Revenues</b>			
Charges for services:			
Ordinance fees	\$ 1,814,319	\$ -	\$ 1,814,319
Intergovernmental grants and contributions		40,782	40,782
Investment earnings	93,233		93,233
Total revenues	<u>1,907,552</u>	<u>40,782</u>	<u>1,948,334</u>
<b>Expenditures</b>			
Current:			
Salaries and benefits		31,204	31,204
Materials and services	8,857	9,578	18,435
Total expenditures	<u>8,857</u>	<u>40,782</u>	<u>49,639</u>
Net change in fund balances	1,898,695		1,898,695
Fund balances - beginning of fiscal year	227,429		227,429
Fund balances - end of fiscal year	<u>\$ 2,126,124</u>	<u>\$ -</u>	<u>\$ 2,126,124</u>

**PLEASANT VALLEY RECREATION AND PARK DISTRICT  
STAFF REPORT / AGENDA REPORT**

**TO: BOARD OF DIRECTORS**

**FROM: MARY OTTEN, GENERAL MANAGER**  
**By: Matthew Parker, Park Services Manager**

**DATE: March 5, 2025**

**SUBJECT: CONSIDERATION AND APPROVAL OF BID AWARD  
FOR TYPE 1 SLURRY SEAL / SEALCOAT AND  
STRIPING AT VARIOUS PARK PARKING LOTS**

**BACKGROUND**

The District is committed to maintaining and enhancing the infrastructure of its parks and facilities to ensure the safety, functionality, and aesthetic appeal of these public spaces. A key component of this infrastructure is the parking lots, which serve as the entry points for park visitors and contribute to the overall accessibility and usability of the parks.

As part of the District's proactive infrastructure management and maintenance, Staff identified the need for Type 1 slurry seal and striping at various park parking lots. This preventative maintenance treatment is designed to protect asphalt surfaces from water infiltration, weathering, and deterioration, thereby extending the pavement's lifespan while improving safety through clear and visible markings.

The project scope includes three parking lots at the following parks:

1. Mel Vincent Park
2. Pitts Ranch Park
3. Pleasant Valley Fields

This project is part of a broader maintenance effort, with three additional parking lots requiring ADA-related modifications to be addressed in a separate phase. The total budget allocated for all six parking lots is \$495,150.

**ANALYSIS**

A Request for Proposal (RFP) was issued on January 10, 2025, soliciting bids for Type 1 slurry seal and striping services. The scope of work includes:

- Cleaning existing pavement surfaces to remove debris, dirt, and any loose materials that could interfere with the adhesion of the slurry seal.
- Application of Type 1 slurry seal, a pavement preservation method that involves applying a mixture of asphalt emulsion, fine aggregate, mineral fillers, and performance-enhancing additives to the surface of existing asphalt pavement.

- Re-striping of parking stalls and other pavement markings, including ADA-compliant spaces, directional arrows, and fire lane designations, ensuring clear visibility and adherence to safety regulations.

A mandatory job walk was held on January 22, 2025, to provide interested contractors with an opportunity to review the project site conditions, clarify any scope-related questions, and ensure a comprehensive understanding of the work required. This walk-through allowed contractors to assess factors such as pavement conditions, accessibility for equipment, potential project constraints, and scheduling considerations. Representatives from three contractor firms attended:

1. American Asphalt South, Inc.
2. PaveWest, Inc.
3. Pavement Coatings Co.

The deadline for bid submissions was February 14, 2025. Of the three contractors that attended the mandatory job walk, only **Pavement Coatings Co.** submitted a formal bid. Their submitted proposal was **\$171,409.69**, covering all aspects of the project, including surface preparation, Type 1 slurry seal application, and restriping. Following the submission, staff conducted a thorough evaluation of the bid, assessing its responsiveness and responsibility in accordance with the project requirements. This included verifying compliance with technical specifications, contractor qualifications, past project performance, and adherence to local and state regulations. After reviewing all aspects of the proposal, staff determined that Pavement Coatings Co. met all project requirements.

### **FISCAL IMPACT**

The project cost will be funded from the Fiscal Year 2024-2025 Capital Budget. The total budget for the six parking lots is \$495,150. The submitted proposal from **Pavement Coatings Co.** is **\$171,409.69**. To account for potential contingencies, Staff recommends an additional 10% contingency, bringing the total authorized amount to **\$188,550.66**.

### **STRATEGIC PLAN COMPLIANCE**

Meets 2021-2026 Strategic Plan Goal and Strategy

- 3.1: Renovate and modernize existing parks and recreation facilities to ensure all parks provide an adequate range and supply of active leisure facilities to meet the growth and diversity in population, programming trends, and new design standards.

### **RECOMMENDATION**

Staff recommends that the Board of Directors approve the bid award and contract for Type 1 slurry seal and striping at Mel Vincent Park, Pitts Ranch Park, and Pleasant Valley Fields to Pavement Coatings Co. for an amount not to exceed \$188,550.66 and authorize the General Manager to execute all necessary agreements and documents related to the project.

### **ATTACHMENTS**

- 1) Pavement Coatings proposal (28 pages)
- 2) Project Agreement (40 pages)

**BID FORM**

FIRM NAME: Pavement Coatings Co.

POINT OF CONTACT: Pete Snyder

ADDRESS: 736 Mission Rock Rd. Santa Paula CA 93060

TELEPHONE NUMBER: (805) 647-0693

FAX NUMBER: (805) 525-4438

FOR THE

**PARKING LOT SLURRY SEALING PROJECT**

**SPEC NO. SSVPL-24-25**

**FISCAL YEAR 2024-2025**

**PLEASANT VALLEY RECREATION & PARK DISTRICT**

**BID FOR THE  
PARKING LOT SLURRY SEALING PROJECT**

**SPEC NO. SSVPL-24-25**

TO THE PLEASANT VALLEY RECREATION & PARK DISTRICT:

This Bid is submitted in accordance with the advertised “Notice Inviting Sealed Bids” to perform all work and improvements therein described, and to furnish all labor and materials, equipment and incident insurance necessary therefor, in accordance with the specifications therefor known as “**PARKING LOT SLURRY SEALING PROJECT, SPEC NO. SSVPL-24-25**” which are on file in the office of the Parks of the Pleasant Valley Recreation & Park District.

Definition of Terms (for a complete definition of terms, see Standard Specifications for Public Works Construction, 2021 Edition):

CY .....	Cubic yard
EA .....	Each
LF .....	Linear foot
LS .....	Lump sum
SF .....	Square foot
SY .....	Square yard
TON .....	Ton

The undersigned Bidder hereby proposes and agrees to enter into a contract to perform the work and improvements therein mentioned to the satisfaction of and under the supervision of the Parks of the Pleasant Valley Recreation & Park District, duly appointed for said work in the matter of the construction and installation of “**PARKING LOT SLURRY SEALING PROJECT, SPEC NO. SSVPL-24-25**”, for the sum set forth in the following schedule:

NOTE: The estimated quantities shown herein are approximate and to be used only for comparison of bids. Payment for quantities will be made for actual materials used on the job and based on the unit costs shown below. The District reserves the right to increase or decrease the amount of any quantity shown and to delete all or any item from the contract.



**PLEASANT VALLEY RECREATION & PARK DISTRICT**

**PARKING LOT SLURRY SEALING PROJECT  
SPEC NO. SSVPL-24-25**

**BID SCHEDULE**

ITEM NO.	DESCRIPTION	ESTIMATED QUANTITY	UNIT	UNIT COST	TOTAL ITEM AMOUNT	NOTE
1.	GRIND ASPHALT AT 10 H/CAREAS 10'X2' @ 5'X6' ROOT, SKIN PATCH 5'X6'	230'	SF	\$ 70.22	\$ 16,153.53	1 MOBILIZATION
2.	HOT CRACK FILL AV FIELD, PITTS RANCH MPL VINCENT PARKS	1	LS	\$ 15,360.00	\$ 15,360.00	1 MOBILIZATION
3.	MOBILIZATION FOR SLURRY SEAL TYPE 1	1	LS	\$ 7,715.00	\$ 7,715.00	
4.	APPLICATION OF SLURRY SEAL TYPE 1	188,272	SF	\$ 0.53	\$ 99,784.16	AV Fields PITTS RANCH MPL VINCENT
5.	RESTRIPE LAY REINSTALL speed bump	1	LS	\$ 32,400.00	\$ 32,400.00	RESTRIPE NEW CROSS WALKS
6.						
7.						
8.						
9.						
10.						
11.						
12.						
13.						
14.						
15.						

ITEM NO.	DESCRIPTION	ESTIMATED QUANTITY	UNIT	UNIT COST	TOTAL ITEM AMOUNT	NOTE
16.						
17.						
18.						
19.						
20.						
21.						
22.						
23.						
24.						
TOTAL BID AMOUNT IN FIGURES					\$171,409.69	
TOTAL BID AMOUNT IN WORDS					ONE HUNDRED SEVENTY ONE THOUSAND FOUR HUNDRED NINE DOLLARS AND SIXTY NINE CENTS.	

PAVEMENT COATINGS CO.  
Bidder Name

Pete Snyder  
Signature of Bidder

Dated 2/10/2025

**ADDENDUM NO. 1**

**PARKING LOT SLURRY SEALING PROJECT**

**SPEC NO. SSVPL-24-25**

January 30, 2025

This Addendum form is a part of the Contract Documents for the above-identified project and modifies the original Specifications and Contract Documents, as noted on the following pages. Portions of the Contract, not specifically mentioned in this Addendum, remain in force. All trades affected shall be fully advised of these changes, deletions, and additions.

**The proposal due date is 10:00am on February 14, 2024.**



Matthew Parker  
Park Services Manager  
Pleasant Valley Recreation and Park District

**PROPOSER'S CERTIFICATE**

I acknowledge receipt of all four (4) pages of this Addendum No. 1 and accept the aforementioned.

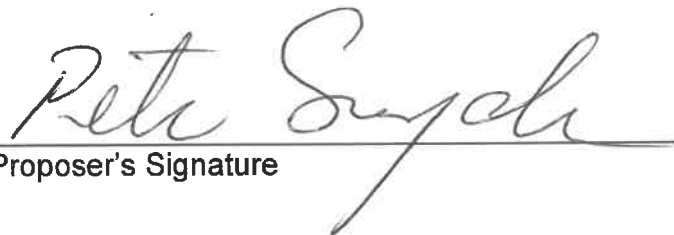

Proposer's Signature



Date

**THIS DOCUMENT TO BE SIGNED  
AND SUBMITTED WITH PROPOSAL**

**PARKING LOT SLURRY SEALING PROJECT  
SPEC NO. SSVPL-24-25**

January 30, 2025

**ADDENDUM NO. 1**

The following additions and/or corrections shall become a part of the Contract Documents and Specifications for the above-named project. When submitting a proposal for the project, this Addendum shall be acknowledged, and ***a signed copy of the Addendum shall be included in the proposal package.***

***Changes or clarifications are noted are BOLD and UNDERLINED***

**I. GENERAL**

The proposer is directed to make the following corrections, deletions, and/or additions to the contract documents and contract drawings heretofore dispensed to him for the above project, and to note proposer's receipt of this addendum by number on the attached ***Addenda Acknowledgement Form:***

**II. MODIFICATIONS TO PREVIOUS ADDENDA**  
N/A

**III. PROPOSAL AND CONTRACT REQUIREMENT REVISIONS**

- 1. Add Alternative Bid for Two-Coat Sealcoat Application**  
This addendum serves to incorporate an **Add Alternative Bid** for a two-coat sealcoat application to the original scope of work for parking lot slurry seal project. The following outlines the specifications, scope, and bid requirements for the add alternative: **(See Specifications on Pg. 3 & 4 of this Addendum use Bid Alt Schedule form on page 5 of this Addendum).**
- 2. Change Crack sealing Specifications from cold pour to hot-pour rubberized asphalt crack sealant (RFP Technical Provisions Pg. 73 or TP-1, section 1. A-E): (See Hot Pour Sealant Specifications on Pg. 3 & 4 of this Addendum)**
- 3. Add and include in the Bid - One (1) - 3'x5' skim patch:**  
This Item was discussed at the mandatory job walk. Skim patch was recommended to correct a small asphalt upheaval caused by a tree roots at pleasant Valley Fields.
- 4. Include adding additional 6" yellow striping for the four (4) crosswalks at Pleasant Valley Fields and reconfiguration of the layout for the two ADA handicap stalls within the east parking area.**

## Crack Seal and Sealcoat Specifications

---

### Part 1: General

#### 1.1 Description

- This section specifies materials and procedures for asphalt parking lot sealcoating using **GardTop** or equivalent sealcoat materials and crack sealing with **Hot Pour Crack Filler** by **GuardTop** or equal, hot-applied rubberized crack sealant.
- 

### Part 2: Materials

#### 2.1 Sealcoat

- Product: **GardTop** or equivalent asphalt emulsion-based sealcoat.
- Additives:
  - Sand (2-4 lbs per gallon of sealcoat) for durability and traction.
  - Latex or polymer modifiers as required by manufacturer.
- Application rate: 0.10 - 0.15 gallons per square yard per coat.
- Certification: VOC-compliant and meets CARB standards.

#### 2.2 Crack Sealant

- Type: **GardTop** or equivalent, Hot-applied rubberized asphalt crack sealant conforming to **ASTM D6690**.
  - Properties:
    - Flexible, durable, and capable of withstanding temperature fluctuations.
    - Designed for cracks up to 1" wide.
  - Heating: Use a double-jacketed melter applicator to heat the material to the manufacturer's specified temperature (typically 380°F–400°F).
- 

### Part 3: Execution

#### 3.1 Preparation

1. **Cleaning:**
  - Sweep and blow off all dirt and debris. Use pressure washing to remove grease and oil.
  - Treat oil spots with a primer before sealcoat application.
2. **Crack Sealing:**

- Clean cracks of loose debris using compressed air or a wire brush.
- Heat and apply hot rubberized crack sealant using a melter applicator.
- Fill cracks flush with the surface, ensuring no overfill.
- Allow sealant to cool and cure per manufacturer's recommendations before proceeding with sealcoat application.

### 3.2 Application of Sealcoat

#### 1. Conditions:

- Do not apply if rain is forecast or temperatures are below 50°F.

#### 2. Mixing:

- Mix **GardTop** sealcoat material as per manufacturer's specifications, including sand and modifiers.

#### 3. Application:

- Apply two coats using a spray or squeegee method.
- Allow the first coat to cure (4-6 hours, depending on conditions) before applying the second coat.

#### 4. Curing:

- Allow a minimum of 24-48 hours before opening the lot to traffic.

**When submitting a proposal for the project, this Addendum shall be acknowledged, and a signed copy of the Addendum shall be included in the proposal package.**

**PLEASANT VALLEY RECREATION & PARK DISTRICT**

**PARKING LOT SLURRY SEALING PROJECT  
SPEC NO. SSVPL-24-25**

**BID ALTERNATIVE SCHEDULE  
Two-Coat Sealcoat Application**

ITEM NO.	DESCRIPTION	ESTIMATED QUANTITY	UNIT	UNIT COST	TOTAL ITEM AMOUNT	NOTE
1.	Two-Coat Sealcoat Application at Mel Vincent Park	4770	SF	\$ 1.56	\$ 7441.20	1 MOB
2.	Two-Coat Sealcoat Application at Pitts Ranch Park	10,395	SF	\$ 0.97	\$ 10,083.15	1 MOB
3.	Two-Coat Sealcoat Application at Pleasant Valley Fields	173,107	SF	\$ 0.40	\$ 69,242.80	1 MOB
4.						
5.						
6.						
TOTAL BID AMOUNT IN FIGURES					\$ 86,767.15	
TOTAL BID AMOUNT IN WORDS						Eighty Six THOUSAND Seven Hundred Sixty Seven dollars and FIFTEEN cents.

PAVEMENT COATINGS CO.  
Bidder Name

Pete Snyder  
Signature of Bidder

Dated 2/10/2025

**RESOLUTION OF CONSTRUCTION CLAIMS**

(To Be Executed By Bidder and Submitted With Bid)

When a Public Works claim is made to the District, the District will conduct a reasonable review of the claim and, within 45 days, provide the claimant with a written statement identifying what portion of the claim is disputed and what portion is undisputed and both parties shall work to resolve the claim as by Public Contract Code 9204. (A copy of Section 9204 may be found in the Special Provisions, under "Resolution of Construction Claims").

Additionally, in all Public Works claims, which may arise between the Contractor and the District which do not exceed the sum of three hundred seventy-five thousand dollars (\$375,000), the requirements of California Public Contract Code, Section 20104 through 20104.6, inclusive, shall apply. (A copy of said Code Sections may be found in the Special Provisions, under "Resolution of Construction Claims of \$375,000 or Less".) Said Code Sections shall apply for the purpose of filing claims and civil actions for claims as defined in Section 20104 of the Public Contract Code.

The bidder's signature is required to verify he/she has reviewed the Code Sections.

Pavement Coatings Co.  
Bidder Name

Pete Snyder  
Signature of Bidder

Dated 2/10/2025



**BID BOND**

(10% of the Bid Amount)

KNOW ALL MEN BY THESE PRESENTS that we Pavement Coatings Co.  
as Principal, hereinafter referred to as "Contractor" and OHIO CASUALTY Insurance Co.  
as Surety, are held and firmly bound unto the Pleasant Valley Recreation & Park District,  
hereinafter called the "District," in the sum of  
One hundred seventy one thousand four hundred and six Dollars (\$ 171,406.00), for the  
payment of which sum well and truly to be made, we bind ourselves, our heirs, executors,  
administrators, and successors, jointly and severally, firmly by these presents. The conditions of  
this obligation are such that whereas the Contractor submitted to the District a certain Bid, attached  
hereto and hereby made a part hereof, to enter into a contract in writing for the Pleasant Valley  
Recreation and Park District

and will furnish all required certificates of insurance and bonds as required by the Contract.

NOW, THEREFORE, if said Bid shall be rejected; or in the alternate, if said Bid is accepted, and  
the Contractor (i) executes and delivers a contract in the prescribed form of the Agreement, (ii)  
delivers certificates evidencing that the required insurance is in effect, (iii) executes and delivers  
Performance and Payment Bonds in the forms prescribed, and (iv) in all other respects performs  
the agreement created by the acceptance of said Bid, then this obligation shall be void; otherwise  
this obligation shall remain in full force and effect, it being expressly understood and agreed that  
the liability of the Surety for any and all default of the Contractor hereunder shall be the amount  
of this obligation as herein stated. In the event suit is brought upon this bond by District and  
judgment is recovered, Surety shall pay all costs incurred by District in said suit, including a  
reasonable attorney's fee to be fixed by the court.

The Surety, for the value received, hereby stipulates and agrees that the obligations of said Surety  
and its bond shall in no way be impaired or affected by an extension of the time within which the  
District may accept such a bid; and said Surety does hereby waive notice of any such extension.

IN WITNESS WHEREOF, the above-bound parties have executed this instrument under their  
several seals this \_\_\_ day of \_\_\_\_\_, 202\_\_, the name and corporate seal of  
each corporate party being hereto affixed and these presents duly signed by its undersigned  
representative, pursuant to authority of its governing body.

ATTEST:

Pavement Coatings Co.

(Contractor)

736 Mission Rock Rd.

(Address)

Santa Paula, CA 93060

**BID BOND**  
(10% of the Bid Amount)

**KNOW ALL MEN BY THESE PRESENTS** that we Pavement Coatings Co.  
as Principal, hereinafter referred to as "Contractor" and The Ohio Casualty Insurance Company  
as Surety, are held and firmly bound unto the Pleasant Valley Recreation & Park District,  
hereinafter called the "District," in the sum of  
Ten Percent of Amount Bid 171,409.69 Dollars (\$ 10% of Amt Bid), for the  
payment of which sum well and truly to be made, we bind ourselves, our heirs, executors,  
administrators, and successors, jointly and severally, firmly by these presents. The conditions of  
this obligation are such that whereas the Contractor submitted to the District a certain Bid, attached  
hereto and hereby made a part hereof, to enter into a contract in writing for the \_\_\_\_\_  
Various Parks – Parking Lot Slurry Sealing Project

and will furnish all required certificates of insurance and bonds as required by the Contract.

**NOW, THEREFORE**, if said Bid shall be rejected; or in the alternate, if said Bid is accepted, and  
the Contractor (i) executes and delivers a contract in the prescribed form of the Agreement, (ii)  
delivers certificates evidencing that the required insurance is in effect, (iii) executes and delivers  
Performance and Payment Bonds in the forms prescribed, and (iv) in all other respects performs  
the agreement created by the acceptance of said Bid, then this obligation shall be void; otherwise  
this obligation shall remain in full force and effect, it being expressly understood and agreed that  
the liability of the Surety for any and all default of the Contractor hereunder shall be the amount  
of this obligation as herein stated. In the event suit is brought upon this bond by District and  
judgment is recovered, Surety shall pay all costs incurred by District in said suit, including a  
reasonable attorney's fee to be fixed by the court.

The Surety, for the value received, hereby stipulates and agrees that the obligations of said Surety  
and its bond shall in no way be impaired or affected by an extension of the time within which the  
District may accept such a bid; and said Surety does hereby waive notice of any such extension.

IN WITNESS WHEREOF, the above-bound parties have executed this instrument under their  
several seals this 11th day of February, 2025, the name and corporate seal of  
each corporate party being hereto affixed and these presents duly signed by its undersigned  
representative, pursuant to authority of its governing body.

ATTEST:

Pavement Coatings Co.  
(Contractor)  
736 Mission Rock Road, Santa Paula, CA 93060  
(Address)

Guy Tittlein. pavement coating, Co  
(By)  
[Signature]  
(Title) Division manager

ATTEST:

The Ohio Casualty Insurance Company  
(Surety)

175 Berkeley St., Boston, MA 02116  
(Address)

[Signature]

Marisella Rivera  
(By)

Attorney-in-Fact  
(Title)

(To be filled in by Surety):

The rate of premium on this bond is \$ 0 per thousand.

The total amount of premium charged is \$ n/a

**NOTARY PUBLIC ATTACH CALIFORNIA ALL-PURPOSE ACKNOWLEDGEMENT**





This Power of Attorney limits the acts of those named herein, and they have no authority to bind the Company except in the manner and to the extent herein stated.

Liberty Mutual Insurance Company
The Ohio Casualty Insurance Company
West American Insurance Company

Certificate No: 8208193-971991

POWER OF ATTORNEY

KNOWN ALL PERSONS BY THESE PRESENTS: That The Ohio Casualty Insurance Company is a corporation duly organized under the laws of the State of New Hampshire, that Liberty Mutual Insurance Company is a corporation duly organized under the laws of the State of Massachusetts, and West American Insurance Company is a corporation duly organized under the laws of the State of Indiana (herein collectively called the "Companies"), pursuant to and by authority herein set forth, does hereby name, constitute and appoint, Brian A. McGoldrick, Brigid Lopez, Evett Lam, Marisella Rivera

all of the city of Placentia state of CA each individually if there be more than one named, its true and lawful attorney-in-fact to make, execute, seal, acknowledge and deliver, for and on its behalf as surety and as its act and deed, any and all undertakings, bonds, recognizances and other surety obligations, in pursuance of these presents and shall be as binding upon the Companies as if they have been duly signed by the president and attested by the secretary of the Companies in their own proper persons.

IN WITNESS WHEREOF, this Power of Attorney has been subscribed by an authorized officer or official of the Companies and the corporate seals of the Companies have been affixed thereto this 21st day of June, 2022.



Liberty Mutual Insurance Company
The Ohio Casualty Insurance Company
West American Insurance Company

By: David M. Carey, Assistant Secretary

State of PENNSYLVANIA ss
County of MONTGOMERY

On this 21st day of June, 2022 before me personally appeared David M. Carey, who acknowledged himself to be the Assistant Secretary of Liberty Mutual Insurance Company, The Ohio Casualty Company, and West American Insurance Company, and that he, as such, being authorized so to do, execute the foregoing instrument for the purposes therein contained by signing on behalf of the corporations by himself as a duly authorized officer.

IN WITNESS WHEREOF, I have hereunto subscribed my name and affixed my notarial seal at King of Prussia, Pennsylvania, on the day and year first above written.



Commonwealth of Pennsylvania - Notary Seal
Teresa Pastella, Notary Public
Montgomery County
My commission expires March 28, 2025
Commission number 1126044
Member, Pennsylvania Association of Notaries

By: Teresa Pastella, Notary Public

This Power of Attorney is made and executed pursuant to and by authority of the following By-laws and Authorizations of The Ohio Casualty Insurance Company, Liberty Mutual Insurance Company, and West American Insurance Company which resolutions are now in full force and effect reading as follows:

ARTICLE IV - OFFICERS: Section 12. Power of Attorney.

Any officer or other official of the Corporation authorized for that purpose in writing by the Chairman or the President, and subject to such limitation as the Chairman or the President may prescribe, shall appoint such attorneys-in-fact, as may be necessary to act in behalf of the Corporation to make, execute, seal, acknowledge and deliver as surety any and all undertakings, bonds, recognizances and other surety obligations. Such attorneys-in-fact, subject to the limitations set forth in their respective powers of attorney, shall have full power to bind the Corporation by their signature and execution of any such instruments and to attach thereto the seal of the Corporation. When so executed, such instruments shall be as binding as if signed by the President and attested to by the Secretary. Any power or authority granted to any representative or attorney-in-fact under the provisions of this article may be revoked at any time by the Board, the Chairman, the President or by the officer or officers granting such power or authority.

ARTICLE XIII - Execution of Contracts: Section 5. Surety Bonds and Undertakings.

Any officer of the Company authorized for that purpose in writing by the chairman or the president, and subject to such limitations as the chairman or the president may prescribe, shall appoint such attorneys-in-fact, as may be necessary to act in behalf of the Company to make, execute, seal, acknowledge and deliver as surety any and all undertakings, bonds, recognizances and other surety obligations. Such attorneys-in-fact subject to the limitations set forth in their respective powers of attorney, shall have full power to bind the Company by their signature and execution of any such instruments and to attach thereto the seal of the Company. When so executed such instruments shall be as binding as if signed by the president and attested by the secretary.

Certificate of Designation - The President of the Company, acting pursuant to the Bylaws of the Company, authorizes David M. Carey, Assistant Secretary to appoint such attorneys-in-fact as may be necessary to act on behalf of the Company to make, execute, seal, acknowledge and deliver as surety any and all undertakings, bonds, recognizances and other surety obligations.

Authorization - By unanimous consent of the Company's Board of Directors, the Company consents that facsimile or mechanically reproduced signature of any assistant secretary of the Company, wherever appearing upon a certified copy of any power of attorney issued by the Company in connection with surety bonds, shall be valid and binding upon the Company with the same force and effect as though manually affixed.

I, Renee C. Llewellyn, the undersigned, Assistant Secretary, The Ohio Casualty Insurance Company, Liberty Mutual Insurance Company, and West American Insurance Company do hereby certify that the original power of attorney of which the foregoing is a full, true and correct copy of the Power of Attorney executed by said Companies, is in full force and effect and has not been revoked.

IN TESTIMONY WHEREOF, I have hereunto set my hand and affixed the seals of said Companies this 11th day of February, 2025.



By: Renee C. Llewellyn, Assistant Secretary

Not valid for mortgage, note, loan, letter of credit, currency rate, interest rate or residual value guarantees.

For bond and/or Power of Attorney (POA) verification inquiries, please call 610-832-8240 or email HOSUR@libertymutual.com.

Guy Littleman  
(By)  
Division Mgr. vice president  
(Title)

ATTEST:

\_\_\_\_\_  
(Surety)

\_\_\_\_\_  
(Address)

\_\_\_\_\_

\_\_\_\_\_  
(By)

\_\_\_\_\_  
(Title)

(To be filled in by Surety):

The rate of premium on this bond is \$ \_\_\_\_\_ per thousand.

The total amount of premium charged is \$ \_\_\_\_\_

**NOTARY PUBLIC ATTACH CALIFORNIA ALL-PURPOSE ACKNOWLEDGEMENT**

**CALIFORNIA NOTARY ACKNOWLEDGEMENT  
(INDIVIDUAL)**

A notary public or other officer completing this certificate verifies only the identity of the individual who signed the document to which this certificate is attached, and not the truthfulness, accuracy, or validity of that document.

State of California  
County of Ventura

On 7/13/2025 before me Gabriel Donald Aguirre Toviás, Notary Public  
personally appeared Guy Tittlemier, who proved to me  
on the basis of satisfactory evidence to be the person(s) whose name(s) is are subscribed to the  
within instrument and acknowledged to me that he she/they executed the same in his her/their  
authorized capacity(ies), and that by his her/their signature(s) on the instrument the person(s),  
or the entity upon behalf of which the person(s) acted, executed the instrument.

I certify under PENALTY OF PERJURY under the laws of the State of California that the foregoing paragraph is true and correct.

WITNESS my hand and official seal.

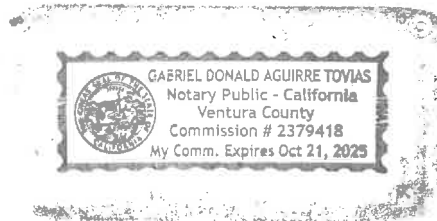

Signature

Guy Tittlemier

(Seal)

## INFORMATION REQUIRED OF BIDDERS

**The bidder is required to supply the following information.**

(Additional sheets may be attached if necessary.)

- (1) Address: 736 MISSION ROCK RD SANTA PAULA CA 93066
- (2) Telephone: 805 647-0693
- (3) Type of Firm: CORPORATION - ESOP  
(Individual, Partnership, or Corporation)
- (4) Contractor's State License Classification C-32 Expiration date \_\_\_\_\_
- (5) Corporate organized under the laws of the State of: CALIFORNIA
- (6) Is 51% or more of the business owned by: American Indian ( ), Asian ( ), Black ( ), Hispanic ( ), Female ( ), Other (Specify) \_\_\_\_\_.

(7) List the names and addresses of all members of the firm, or names and titles of all officers of the corporation.

TIM SCHMID President  
TOM MUCENSKI SECRETARY  
RICHARD YAWNEY CFO  
Gary Titlemire Vice President

(8) Number of years of experience as a Contractor in construction work. 30+

(9) List at least three (3) completed \_\_\_\_\_ projects completed in the last \_\_\_ months:

Contract Amount	Class of Work	Date Completed	Name, Contact, Address and Telephone No. of Client
\$7,351.24	Type II Slurry	11/25/24	Port Hueneke, Ray G., 250 N. Ventura Rd., Port Hueneke CA, (805) 986-6599 93041

Contract Amount	Class of Work	Date Completed	Name, Contact, Address and Telephone No. of Client
\$75,103.73	SEAL COAT	1/16/23	Santa Clarita, Peter H., 23920 Valencia Blvd., Valencia CA, (661) 259-2489 91355

Contract Amount	Class of Work	Date Completed	Name, Contact, Address and Telephone No. of Client
\$4,974.10	ASPHALT PATCH WORK	7/01/24	Pleasant Valley Parks & Rec., Bob, 1605 Burnley St., Camarillo, CA (805) 432-1906 93010,



(10) List the name of the person who inspected the site of the proposed work for your firm:

Date of Inspection: Pete Snyder  
1/3/25

(11) If requested by the District, the Bidder shall furnish a notarized financial statement, financial data, or other information and reference sufficiently comprehensive to permit an appraisal of Bidder's current financial condition.

(12) List the name and address of all **subcontractors who will perform work** in or about the project and indicate what part of the work will be done by each such Subcontractor.

NAME: Interstate Striping & Signs  
ADDRESS: 1200 Lawrence Dr. Suite 340 Newbury Park CA 91320  
LICENSE NO. & CLASS: 838618 - C-32  
WORK TO BE PERFORMED: Crack Fill & Striping

NAME: Pavement Recycling Systems  
ADDRESS: 10240 SAN SEVAINNE WAY JURUPA VALLEY CA 91752  
LICENSE NO. & CLASS: 303609 - A  
WORK TO BE PERFORMED: MICRO MILL / GRIND ASPHALT

NAME: \_\_\_\_\_  
ADDRESS: \_\_\_\_\_  
LICENSE NO. & CLASS: \_\_\_\_\_  
WORK TO BE PERFORMED: \_\_\_\_\_

NAME: \_\_\_\_\_  
ADDRESS: \_\_\_\_\_  
LICENSE NO. & CLASS: \_\_\_\_\_  
WORK TO BE PERFORMED: \_\_\_\_\_

NAME: \_\_\_\_\_  
ADDRESS: \_\_\_\_\_  
LICENSE NO. & CLASS: \_\_\_\_\_  
WORK TO BE PERFORMED: \_\_\_\_\_

List the name and address of **Major Equipment Suppliers** who will provide equipment or major components for the project.

NAME: \_\_\_\_\_  
ADDRESS: \_\_\_\_\_  
EQUIPMENT TO BE PROVIDED: \_\_\_\_\_

NAME: \_\_\_\_\_  
ADDRESS: \_\_\_\_\_  
EQUIPMENT TO BE PROVIDED: \_\_\_\_\_

NAME: \_\_\_\_\_  
ADDRESS: \_\_\_\_\_  
EQUIPMENT TO BE PROVIDED: \_\_\_\_\_

NAME: \_\_\_\_\_  
ADDRESS: \_\_\_\_\_  
EQUIPMENT TO BE PROVIDED: \_\_\_\_\_

NAME: \_\_\_\_\_  
ADDRESS: \_\_\_\_\_  
EQUIPMENT TO BE PROVIDED: \_\_\_\_\_

(13) The Contractor shall furnish the following information concerning bid depository or registry services used in obtaining subcontractor bid figures for this Bid. Additional sheets may be attached if necessary.

A. Were bid depository or registry services used in obtaining subcontractor bid figures in order to compute your bid? Yes ( ) No (✓)

B. If the answer to "A." is "Yes," forward a copy of the rules of each bid depository you used in the preparation of this Bid.

C. Did you have any source of subcontractor bids other than bid depositories? Yes ( ) No (✓)

D. Has any person or group threatened you with subcontractor boycotts, union boycotts, or other sanctions to attempt to convince you to use the services or abide by the rules of one or more bid depositories? Yes ( ) No (✓)

E. If the answer to "D" is "Yes", please explain the following details:

(a) Date: \_\_\_\_\_

(b) Name of person or group: \_\_\_\_\_

(c) Job involved (if applicable): \_\_\_\_\_

(d) Nature of threats: \_\_\_\_\_

\_\_\_\_\_  
\_\_\_\_\_  
\_\_\_\_\_

(e) Additional comments: \_\_\_\_\_

\_\_\_\_\_  
\_\_\_\_\_  
\_\_\_\_\_

**(TO ACCOMPANY BID)**

In accordance with Public Contracting Code Section 10162, the bidder shall complete, under penalty of perjury, the following questionnaire:

**QUESTIONNAIRE**

Has the bidder, any officer of the bidder, or any employee of the bidder who has a proprietary interest in the bidder, ever been disqualified, removed, or otherwise prevented from bidding on or completing a Federal, State, or local government project because of a violation of law or a safety regulation?

Yes \_\_\_\_\_ No  \_\_\_\_\_

If the answer is yes, explain the circumstances in the following space:

Note: This questionnaire constitutes a part of the Bid, and a signature on the Bid shall be constituted a signature on this questionnaire.

# CONTRACTOR LICENSE AFFIDAVIT

STATE OF CALIFORNIA )  
COUNTY OF Ventura ) ss.

Guy Tittlemier, being first duly sworn, deposes  
**Name**

and says that he or she is Vice President of Pavement Coatings Co.,  
**Title Name of Firm**

the party making the foregoing bid, is a licensed Contractor, a duly authorized partner of a Joint Venture which holds a license as a Partnership, or a duly authorized principal and/or representative of a Corporation which holds a license as a Corporation, and that he or she understands the information shown below shall be included with the bid, and understands that any bid not containing this information, or if this information is subsequently proven to be false, shall be considered non-responsive and shall be rejected by the Pleasant Valley Recreation & Park District.

303609, A C32  
**Contractor's State License Number and Classification**  
9/30/2026  
**License Expiration Date**

I certify under penalty of perjury under the laws of the State of California that the foregoing is true and correct.

Subscribed at: Santa Paula, Ventura County, Calif  
(City and County, State)

on Feb 13, 2025.

  
Signature

303609, A C32  
State License Number and Classification

736 Mission Rock Road, Santa Paula CA 93060  
Street Address City State Zip Code

Telephone Number 805-647-0693

A notary public or other officer completing this certificate verifies only the identity of the individual who signed the document to which this certificate is attached, and not the truthfulness, accuracy or validity of that document.

STATE OF CALIFORNIA )  
COUNTY OF Ventura ) ss.

On February 13<sup>th</sup>, 2025 before me, Gabriel Donald Aguirre <sup>Tovias, Notary Public</sup>, a Notary Public, personally appeared Guy Tittlemier, who proved to me on the basis of satisfactory evidence to be the person(s) whose name(s) is/are subscribed to the within instrument and acknowledged to me that he/she/they executed the same in his/her/their authorized capacity(ies), and that by his/her/their signature(s) on the instrument the person(s), or the entity upon behalf of which the person(s) acted executed the instrument.

I certify under PENALTY OF PERJURY under the laws of the State of California that the foregoing paragraph is true and correct.

WITNESS my hand and official seal.

(Seal)

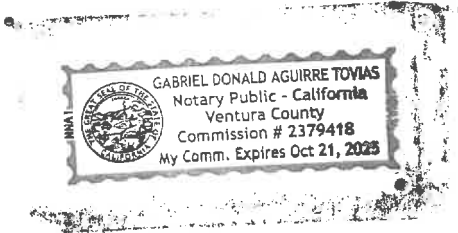

Signature [Handwritten Signature]





CONTRACTORS  
STATE LICENSE BOARD  
ACTIVE LICENSE



License Number **303609**

Entity **CORP**

Business Name **PAVEMENT COATINGS CO**

Classification(s) **A C32**



Expiration Date **09/30/2026**

[www.cslb.ca.gov](http://www.cslb.ca.gov)





Any change of business address/name must be reported to the Registrar within 90 days.

This license is not transferrable, and shall be returned to the Registrar upon demand when suspended, revoked, or invalidated for any reason.

This pocket card is valid through the expiration date only.

If found, drop in any mailbox.  
Postage guaranteed by:  
Contractors State License Board  
P.O. Box 26000, Sacramento CA 95826

Licensee Signature

**NONCOLLUSION DECLARATION TO BE EXECUTED  
BY  
BIDDER AND SUBMITTED WITH BID**

The undersigned declares:

I am the Vice President of Pavement Coatings Co., the party making the foregoing bid.

The bid is not made in the interest of, or on behalf of, any undisclosed person, partnership, company, association, organization, or corporation. The bid is genuine and not collusive or sham. The bidder has not directly or indirectly induced or solicited any other bidder to put in a false or sham bid. The bidder has not directly or indirectly colluded, conspired, connived, or agreed with any bidder or anyone else to put in a sham bid, or to refrain from bidding. The bidder has not in any manner, directly or indirectly, sought by agreement, communication, or conference with anyone to fix the bid price of the bidder or any other bidder, or to fix any overhead, profit, or cost element of the bid price, or of that of any other bidder. All statements contained in the bid are true. The bidder has not, directly or indirectly, submitted his or her bid price or any breakdown thereof, or the contents thereof, or divulged information or data relative thereto, to any corporation, partnership, company, association, organization, bid depository, or to any member or agent thereof, to effectuate a collusive or sham bid, and has not paid, and will not pay, any person or entity for such purpose.

Any person executing this declaration on behalf of a bidder that is a corporation, partnership, joint venture, limited liability company, limited liability partnership, or any other entity, hereby represents that he or she has full power to execute, and does execute, this declaration on behalf of the bidder.

I declare under penalty of perjury under the laws of the State of California that the foregoing is true and correct and that this declaration is executed on 2-12-25 [date], at San Jose [city], San Jose [state]. GR

## AGREEMENT

**THIS AGREEMENT**, made and entered into by and between the **PLEASANT VALLEY RECREATION & PARK DISTRICT, CALIFORNIA**, hereinafter referred to as the "**District**" and Yuma Contractors Co. hereinafter referred to as the "**Contractor**".

**WITNESSETH:** That the parties hereto do mutually agree as follows:

**ARTICLE I:** For and in consideration of the payments and agreements hereinafter mentioned to be made and performed by said District, said Contractor agrees with said District to construct the work under the District's specification entitled "PARKING LOT SLURRY SEALING PROJECT, SPEC NO. PPG-24-25" and to perform and complete in a good and workmanlike manner all the work pertaining thereto shown on the drawings and described in the specifications herein, to furnish at his or her own proper cost and expense all tools, equipment, labor, and materials necessary therefor, except such material and equipment as in said specifications as expressly stipulated to be furnished by said District, and to do everything required by this Agreement and the said specifications and drawings.

**ARTICLE II:** For furnishing all said materials and labor, furnishing and removing all plant, temporary works or structures, tools and equipment and doing all the work contemplated and embraced in this Agreement, also for all loss and damage arising out of the nature of the work aforesaid, or from the action of the elements, or from any unforeseen difficulties which may arise from or be encountered in the prosecution of the work until its acceptance by said District, and for all risks of every description connected with the work; also for all expenses incurred by or in consequence of the suspension or discontinuance of work, except such as in the said specifications are expressly stipulated to be borne by said District, and for well and faithfully completing the work the whole thereof, in the manner shown and described in said drawings and specifications and in accordance with the requirements of the Engineer, said District will pay and said Contractor shall receive in full compensation therefor the prices named in the Bidding Schedule of the Bid hereto attached.

**ARTICLE III:** All work to be done under this contract shall be completed within **Thirty-five (35) consecutive working days**, exclusive of maintenance periods, beginning on the date stipulated in the written Notice to Proceed issued by the Engineer. Any changes in time and/or price are to be submitted to the District Engineer, in writing, within 3 days of the occurrence giving rise to the request and shall request a formal decision from the District within 3 days and shall include data supporting the request.

**ARTICLE IV:** The District hereby promises and agrees with said Contractor to employ, and does hereby employ, said Contractor to provide the materials and to do the work according to the terms and conditions herein contained and referred to for the price aforesaid, and hereby contracts to pay for the same, at the time, in the manner, and upon the conditions set forth in said specifications; and the said parties for themselves, their heirs, executors, administrators, successors, and assigns, do hereby agree to the full performance of the covenants herein contained.

**ARTICLE V:** The Notice Inviting Sealed Bids, the Instructions to Bidders, the Bid, the Specifications, and the Drawings mentioned therein, all addenda issued prior to the opening of the bid by the District, all contract change orders issued after execution of the Contract Agreement, the Special Provisions, Non-Collusion Declaration, Faithful Performance Bond, Payment Bond, all of which are essential parts of this contract, are hereby incorporated in and made part of this Agreement.

**ARTICLE VI:** Contractor acknowledges the provisions of Labor Code Section 1860 requiring every employer to be insured against liability for worker's compensation, or to undertake self-insurance in accordance with the provisions of that code and certifies that it is in compliance with such provisions.

**ARTICLE VII:** The Contractor shall supply the District with Certificates evidencing all required insurance policies as described in the Instructions to Bidders.

**ARTICLE VIII:** The Contractor certifies that he or she is aware of the provisions of Public Contract Code Section 6109 and that any contractor or subcontractor who is ineligible under Labor Code Sections 17771.1 and 1777.7 is prohibited from working on this Project.

**ARTICLE IX:** Contractor acknowledges and agrees to comply with the provisions of the State Labor Code requiring every employer to pay at least the minimum prevailing rate of per diem wages for each craft, classification, or type of workman needed to execute this contract. State general prevailing wage determination as established by the California Department of Industrial Relations (available at <http://www.dir.ca.gov/DLSR/PWD/index.htm>) and the contractor shall post all required job site notices. The statutory provisions for penalties for failure to pay prevailing wages and/or failure to otherwise comply with state's wage and hour laws will be enforced. This contract is subject to compliance monitoring and enforcement by the Department of Industrial Relations. Contractor agrees that eight hours' labor constitutes a legal day's work.

The Contractor hereby agrees that the Contractor, and any subcontractor under the Contractor, shall pay not less than the general prevailing rate of per diem wages, as determined by the Director of the Department of Industrial Relations, to all workers employed in the execution of this contract as required under Subsection 5-3.2 of the 2021 Standard Specifications for Public Works Construction, and shall submit weekly to the District, certified copies of the payroll records for all said workers and shall comply with all statutory requirements relating to certified copies of payroll records, including the maintenance of the records, their certification, and their availability for inspection as required by Labor Code Section 1776 and as required under Subsection 5-3.3 of said Standard Specifications for Public Works Construction. In addition, the Contractor and any subcontractors must furnish electronic certified payroll records directly to the Labor Commissioner (aka Division of Labor Standards Enforcement) in a format prescribed by the Labor Commissioner no less than monthly. The Labor Commissioner may at any time require the contractors and subcontractors to furnish electronic certified payroll records.

The prevailing rate of per diem wages are on file at the Pleasant Valley Recreation & Park District, Department of Public Works, 1605 E. Burnley Street, Camarillo, CA 93010, and are available to any interested party on request. The Contractor is required to post at the job site the prevailing rate

of per diem wages as determined by the Director of the Department of Industrial Relations and other notices prescribed by regulation.

Contractor and any subcontractor under the Contractor must comply with the requirements of California Labor Code Sections 1777.5 and 1777.6 regarding the employment of apprentices.

**ARTICLE X:** The Contractor hereby agrees to indemnify and defend the District, its officers, agents, and employees against, and to hold and save them and each of them harmless from, any and all actions, suits, claims, damages to persons or property, losses, costs, penalties, obligations, errors, omissions, or liabilities (hereinafter "Claims or Liabilities") that may be asserted or claimed by any person, firm, or entity arising out of or in connection with this Agreement, the construction of the project, any alleged breach or breach of any provision set forth in this Agreement or the plans or specifications for the project, design defects, any alleged violation or violation of any federal, state, or local, law, ordinance, statute, rule, regulation, or order, any failure or alleged failure to secure any applicable regulatory permit, license, or agreement, and the errors and omissions, willful misconduct, or negligence, whether said negligence is concurrent, active or passive, of the Contractor, its officers, agents, employees, or any other persons, except that the Contractor shall not be required to indemnify, defend, and hold harmless the District, its officers, agents, and employees against Claims or Liabilities caused by the negligence or willful misconduct or active negligence of the District, its officers, agents, or employees.

**ARTICLE XI:** The District, in accordance with Public Contract Code Section 22300, shall permit the substitution of securities for any moneys withheld by the District to secure performance under a contract. The District hereby incorporates herein all of the provisions set forth in Public Contract Code Section 22300.

**ARTICLE XII:** In the performance of this agreement, the Contractor shall not engage in, nor permit others he or she may hire to engage in, discrimination in the employment of persons because of their race, religious creed, color, or national origin, except as provided in Government Code Section 12940. Violation of this provision may result in the imposition of penalties as provided in Labor Code Section 1735.

**ARTICLE XIII:** Contractor will be compensated for any utility relocation required as part of the project which is not shown on the plans and Contractor will not be assessed liquidated damages for any delays caused by the District's or a public utility's failure to provide for removal or relocation of utility facilities.

**ARTICLE XIV:** The Contractor shall maintain accounts and records, including personnel, property, and financial records, adequate to identify and account for all costs pertaining to the contract and such other records as may be deemed necessary by the District to assure proper accounting for all project funds, both federal and non-federal shares. These records will be made available for audit purposes to the District or any authorized representative and will be retained for 3 years after the expiration of this contract, unless permission to destroy them is granted by the District.

**ARTICLE XV:** No officer or employee of the District shall have any financial interest in this Agreement nor shall any such officer or employee participate in any decision relating to the

Agreement which affects his or her financial interest or the financial interest of any corporation, partnership or association in which he or she is interested, in violation of any State statute or regulation. Similarly, Contractor warrants that it has not paid or given and will not pay or give any third party any money or other consideration for obtaining this Agreement.

**ARTICLE XVI:** The persons executing this Agreement on behalf of the parties hereto warrant that (i) such party is duly organized and existing, (ii) they are duly authorized to execute and deliver this Agreement on behalf of said party, (iii) by so executing this Agreement, such party is formally bound to the provisions of this Agreement, and (iv) the entering into this Agreement does not violate any provision of any other Agreement to which said party is bound.

**ARTICLE XVII:** Legal actions concerning any dispute, claim or matter arising out of or in relation to this Agreement shall be instituted in the Superior Court of the County of Ventura, State of California, or any other appropriate court in such county, and Contractor agrees to submit to the personal jurisdiction of such court in the event of such action.

**ARTICLE XVIII:** District will timely notify Contractor of any third-party claim received by the District relating to this Agreement.

[Signatures on next page]

**DISTRICT: PLEASANT VALLEY  
RECREATION & PARK DISTRICT,  
CALIFORNIA**

Dated \_\_\_\_\_, 202\_

By: \_\_\_\_\_  
\_\_\_\_\_, Chairman

ATTEST:

\_\_\_\_\_  
\_\_\_\_\_, Clerk of the Board

Dated \_\_\_\_\_, 202\_

**CONTRACTOR:** Pleasant Contracting Co

By: \_\_\_\_\_  
AUTHORIZED REPRESENTATIVE

Director mba., vice president  
TITLE

By: \_\_\_\_\_  
AUTHORIZED REPRESENTATIVE

\_\_\_\_\_  
TITLE

(Attach acknowledgment for each  
Authorized Representative of Contractor.)

Address: \_\_\_\_\_

Phone: \_\_\_\_\_

Fax: \_\_\_\_\_

Email: \_\_\_\_\_

## PLEASANT VALLEY RECREATION & PARK DISTRICT

### GENERAL PROVISIONS

#### SCOPE OF WORK:

This project will take place within the Pleasant Valley Recreation & Park District. The work to be done consists of furnishing all materials, equipment, tools, labor, and incidentals as required by the Plans, Specifications, and Contract Documents. The general items of work are provided by Plans, Specifications and Contract Documents.

#### LOCATION OF WORK:

1. Mel Vincent Park – 668 Calistoga Rd., Camarillo, CA 93010
2. Pitts Ranch Park – 1400 Flynn Rd., Camarillo, CA 93012
3. Pleasant Valley Fields – 200 Westpark Court, Camarillo, CA 93012

#### STANDARD SPECIFICATIONS:

The Standard Specifications of the District are contained in the 2021 Edition of the Standard Specifications for Public Works Construction, with amendments and supplements, as written and promulgated by the Joint Cooperative Committee of the Southern California Chapter of the American Public Works Association and the Southern California District of the Associated General Contractors of California (“Greenbook”). Copies of these Standard Specifications are available from the publisher, Building News, Incorporated, 990 Park Center Drive, Suite E, Vista, California 92081; telephone (760) 734-1113.

The Standard Specifications set forth above will control the General Provisions, Construction Materials, and Construction Methods for this Contract, except as amended by the Plans, Special Provisions, or other Contract Documents. The following Special Provisions are supplementary and in addition to the provisions of the Standard Specifications unless otherwise noted and the section numbers of the Special Provisions coincide with those of the said Standard Specifications. Only those sections requiring elaborations, amendments, specifying of the options, or additions are called out.

#### LEGAL ADDRESS OF CONTRACTOR:

The address given in the Contractor's bid on which the contract is founded is hereby designated as the place to which all notices, letters, and other communications to the Contractor shall be mailed or delivered. Unless otherwise required by law, the mailing to or delivering at the above-named place of any notice, letter, or other communication by the District to the Contractor shall be deemed sufficient service thereof upon the Contractor. The date of said service shall be the date of such mailing or delivery. Such address may be changed at any time by a written notice signed by the Contractor and delivered to the Engineer.

#### RECOVERY OF DAMAGES:



The making of an estimate and payment in accordance therewith shall not preclude the District from demanding and recovering from the Contractor such damages as it may sustain by reason of the Contractor's failure to comply with the Specifications.

**MONIES MAY BE RETAINED:**

The District may keep any monies which would otherwise be payable at any time hereunder and apply the same, or so much as may be necessary therefor, to the payment of any expenses, losses, or damages, as determined by the Engineer, incurred by the District, for which the Contractor is liable under the contract.

**SALES AND/OR TAXES:**

Except as may be otherwise specifically provided herein, all sales and/or use taxes assessed by federal, state, or local authorities on materials used or furnished by the Contractor in performing the work hereunder shall be paid by the Contractor.

**ALLOWABLE VARIATION:**

When in these Specifications a maximum or minimum, either in size, percentage, or thickness or relating to quality, character, or other matter, is allowed or prescribed, the work shall be accepted as in compliance if within such maximum or minimum so allowed thereby.

**PROTECTION OF PUBLIC UTILITIES:**

The Contractor shall not be assessed liquidated damages for delay in completion of the project when such delay is caused by failure of the District or owner of a public utility to provide for removal or relocation of existing utility facilities. This Agreement is subject to Government Code Sections 4215 and 4126 – 4216.9. Contractor must notify utilities and obtain an identification number before excavation or be subject to liability for damages to subsurface installations.

**EMERGENCY INFORMATION:**

The names, addresses, and telephone numbers of the Contractor and subcontractors, or their representatives, shall be filed with the Parks Department, the District Fire Department, and the County Sheriff's Department prior to beginning work.

**EMPLOYMENT OF APPRENTICES:**

The Contractor's attention is directed to the provisions of Sections 1777.5 and 1777.6 of the Labor Code concerning the employment of apprentices by the Contractor or any Subcontractor under the Contractor. The Contractor, and any subcontractor under the Contractor, shall comply with the requirements of all statutory provisions relating to the employment of apprentices. Information relative to apprenticeship standards and administration of the apprenticeship program may be obtained from the Director of Industrial Relations, P.O. Box 603, San Francisco, California 94101 or from the Division of Apprenticeship Standards and its branch offices.

**PENALTIES FOR DISCRIMINATION IN EMPLOYMENT:**

Any Contractor who shall be found in violation of the nondiscrimination provisions of the State of California Fair Employment Practices Act or similar provisions of federal law or executive order in the performance of any contract with the District shall be found in material breach of such contract and the District shall have power to cancel or suspend the Contractor, in whole or in part,

or to deduct from the amount payable to such Contractor the sum of twenty-five dollars (\$25.00) for each person for each calendar day during which such person was discriminated against, as damages for said breach of contract; or both. Only a finding of the State of California Fair Employment Practices Commission or the equivalent federal agency or officer shall constitute evidence of a violation of contract under this section.

The Contractor shall enclose with his or her bid a Compliance Report stating that he or she will pursue an affirmative course of action as required by the affirmative action guidelines.

**PROVISIONS REQUIRED BY LAW DEEMED INSERTED:**

Each and every provision of law and clause required by law to be inserted in this contract shall be deemed to be inserted herein, and the contract shall be read and enforced as though it were included herein. If through mistake or otherwise any such provision is not inserted, or is not correctly inserted, then upon application of either party, the contract shall forthwith be physically amended to make such insertion or correction.

**PAYROLL RECORDS:**

The Contractor's attention is directed to the following provisions of Labor Code Section 1776, "Payroll record of wages paid; Inspections; Forms; Effect of noncompliance; Penalties". The Contractor shall be responsible for the compliance with these provisions by his or her subcontractors.

“(a) Each contractor and subcontractor shall keep an accurate payroll record, showing the name, address, social security number, work classification, straight time and overtime hours worked each day and week, and the actual per diem wages paid to each journeyman, apprentice, worker, or other employee employed by him or her in connection with the public work. Each payroll record shall contain or be verified by a written declaration that it is made under penalty of perjury, stating both of the following:

- (1) The information contained in the payroll record is true and correct.
- (2) The employer has complied with the requirements of Sections 1771, 1811, and 1815 for any work performed by his or her employees on the public works project.

(b) The payroll records enumerated under subdivision (a) shall be certified and shall be available for inspection at all reasonable hours at the principal office of the contractor on the following basis:

- (1) A certified copy of an employee's payroll record shall be made available for inspection or furnished to the employee or his or her authorized representative on request.
- (2) A certified copy of all payroll records enumerated in subdivision (a) shall be made available for inspection or furnished upon request to a representative of the body awarding the contract and the Division of Labor Standards Enforcement of the Department of Industrial Relations.
- (3) A certified copy of all payroll records enumerated in subdivision (a) shall be made available upon request to the public for inspection or for copies thereof. However, a request by the public shall be made through either the body awarding the contract or the Division of Labor Standards Enforcement. If the requested payroll records have not been provided

pursuant to paragraph (2), the requesting party shall, prior to being provided the records, reimburse the costs of preparation by the contractor, subcontractors, and the entity through which the request was made. The public may not be given access to such records at the principal office of the contractor.

(c) Unless required to be furnished directly to the Labor Commissioner in accordance with paragraph (3) of subdivision (a) of Section 1771.4, the certified payroll records shall be on forms provided by the Division of Labor Standards Enforcement or shall contain the same information as the forms provided by the division. The payroll records may consist of printouts of payroll data that are maintained as computer records, if printouts contain the same information as the forms provided by the division and the printouts are verified in the manner specified subdivision (a).

(d) A contractor or subcontractor shall file a certified copy of the records enumerated in subdivision (a) with the entity that requested the records within 10 days after receipt of a written request.

(e) Except as provided in subdivision (f), any copy of records made available for inspection as copies and furnished upon request to the public or any public agency by the awarding body or the Division of Labor Standards Enforcement shall be marked or obliterated to prevent disclosure of an individual's name, address, and social security number. The name and address of the contractor awarded the contract or the subcontractor carrying out the contract shall not be marked or obliterated. Any copy of records made available for inspection by, or furnished to, a multiemployer Taft-Hartley trust fund (29 U.S.C. Sec. 175a) shall be marked or obliterated only to prevent disclosure of an individual's full social security number but shall provide the last four digits of the social security number. Any copy of records made available for inspection by, or furnished to, a joint labor-management committee established pursuant to the federal Labor Management Cooperation Act of 1978 (29 U.S.C. Sec. 175a) shall be marked or obliterated only to prevent disclosure of an individual's social security number.

(f)(1) Notwithstanding any other provision of law, agencies that are included in the Joint Enforcement Strike Force on the Underground Economy established pursuant to Section 329 of the Unemployment Insurance Code and other law enforcement agencies investigating violations of law shall, upon request, be provided nonredacted copies of certified payroll records. Any copies of records or certified payroll made available for inspection and furnished upon request to the public by an agency included in the Joint Enforcement Strike Force on the Underground Economy or to a law enforcement agency investigating a violation of law shall be marked or redacted to prevent disclosure of an individual's name, address, and social security number.

(2) An employer shall not be liable for damages in a civil action for any reasonable act or omission taken in good faith in compliance with this subdivision.

(g) The contractor shall inform the body awarding the contract of the location of the records enumerated under subdivision (a), including the street address, city, and county, and shall, within five working days, provide a notice of a change of location and address.

(h) The contractor or subcontractor has 10 days in which to comply subsequent to receipt of written notice requesting the records enumerated in subdivision (a). In the event that the contractor

or subcontractor fails to comply within the 10-day period, he or she shall, as a penalty to the state or political subdivision on whose behalf the contract is made or awarded, forfeit one hundred dollars (\$100) for each calendar day, or portion thereof, for each worker, until strict compliance is effectuated. Upon the request of the Division of Labor Standards Enforcement, these penalties shall be withheld from progress payments then due. A contractor is not subject to a penalty assessment pursuant to this section due to the failure of a subcontractor to comply with this section.

(i) The body awarding the contract shall cause to be inserted in the contract stipulations to effectuate this section.

(j) The director shall adopt rules consistent with the California Public Records Act (Chapter 3.5 (commencing with Section 6250) of Division 7 of Title 1 of the Government Code) and the Information Practices Act of 1977 (Title 1.8 (commencing with Section 1798) of Part 4 of Division 3 of the Civil Code) governing the release of these records, including the establishment of reasonable fees to be charged for reproducing copies of records required by this section.

**ASSIGNMENT OF ANTITRUST ACTIONS:**

The Contractor's attention is directed to the following provision of the Public Contracts Code, Section 7103.5, which shall be applicable to the Contractor and his or her subcontractors:

"(b) In entering into a public works contract or a subcontract to supply goods, services, or materials pursuant to a public works contract, the contractor or subcontractor offers and agrees to assign to the awarding body all rights, title, and interest in and to all causes of action it may have under Section 4 of the Clayton Act (15 U.S.C. Sec. 15) or under the Cartwright Act (Chapter 2 (commencing with Section 16700) of Part 2 Division 7 of Business and Professions Code), arising from purchases of goods, services, or materials pursuant to the public works contract or the subcontract. This assignment shall be made and become effective at the time the awarding body tenders final payment to the contractor, without further acknowledgment by the parties."

**CONSTRUCTION SCHEDULES:**

Prior to issuing the "Notice to Proceed," the Engineer will schedule a preconstruction meeting with the Contractor to review the proposed construction schedule and delivery dates, arrange utility coordination, discuss construction methods, and clarify inspection procedures. The Contractor must provide to the Engineer, at the time of the pre-construction meeting, a schedule in the form of a Gantt Chart for review and approval. Any change in the construction schedule will require the Contractor to provide revised charts of those changes to the Engineer within two (2) working days. The "Notice to Proceed" will be issued upon approval of the project schedule. Requests for changes in the schedule shall be submitted by the Contractor to the Engineer in writing for approval at least 48 hours prior to the scheduled operations on the streets affected.

The schedule shall be broken down into activities by street with durations no greater than one week. No more than 15% of the activities may be on the critical path of the baseline schedule. The Engineer will review the baseline schedule, and the Contractor will make any reasonable changes requested to make the schedule acceptable.

If at any time project completion is ten or more working days behind schedule, the Contractor shall submit a recovery schedule, subject to approval, showing how the original completion date will be met.

**CONSTRUCTION WORKING HOURS:**

The Contractor's regular hours of work will be from 7:00 AM to 5:00 PM on all working days as defined in Section 1-2 of the Greenbook.

**EQUIVALENT MATERIALS:**

Approval of equipment and materials offered as equivalents to those specified must be obtained in writing from the District prior to the opening of bids. Requests for consideration of equivalents must be submitted in writing allowing five (5) working days for complete consideration of all specifications, samples, references, tests, and other details to the full satisfaction of the District.

## **SPECIAL PROVISIONS**

### **PLEASANT VALLEY RECREATION & PARK DISTRICT**

### **PARKING LOT SLURRY SEALING PROJECT**

**SPEC NO. SSVPL-24-25**

**FISCAL YEAR 2024-2025**

#### **1. GENERAL**

**A. THE REQUIREMENT:** All work embraced herein shall be accomplished in accordance with the applicable portions of the "Standard Specifications for Public Works Construction" 2021 edition, plus any supplements, published, herein referred to as "Standard Specifications," except as modified by the General Conditions, these Special Provisions, Standard Drawings and the Project Plans ("Greenbook"). In addition to the above, the Contractor shall comply with the requirements of the following:

- (1) Notice Inviting Sealed Bids
- (2) Instructions to Bidders
- (3) Bid
- (4) Bid Bond
- (5) Information Required of Bidder
- (6) Agreement
- (7) Faithful Performance Bond
- (8) Payment Bond (Labor and Material Bond)

**B. DEFINITION OF TERMS:** Wherever in the Standard Specifications terms are used, they shall be understood to mean and refer to the following:

- (1) District – The Pleasant Valley Recreation & Park District
- (2) Board - The District's governing board
- (3) Director, Engineer - The District's Public Works and District Engineer, acting either directly or through authorized agents. Also referred to herein as District Engineer.
- (4) Other terms appearing in the Standard Specifications, the General Conditions, and these Special Provisions shall have the intent and meaning specified in Section 1 of the Standard Specifications.

**C. SCOPE AND CONTROL OF THE WORK:**

**PROJECT PLANS:** The location of the work, its general nature, extent, form and detail of the various features are shown on drawings accompanying and made a part of these specifications.

Section 2 is amended by adding thereto the following new Subsection 2-1.1 Plans and Specifications:

“2-1.1 Plans and Specifications. The Contractor shall maintain a control set of Plans and Specifications on the project site at all times. All final locations determined in the field, and any deviations from the Plans and Specifications, shall be marked in red on this control set to show the as-built conditions. Upon completion of all work, the Contractor shall return the control set to the Engineer. Final payment will not be made until this requirement is met.”

Section 2 is amended by adding thereto the following new Subsection 2-1.2 Record Drawings:

“2-1.2 Record Drawings.

All corrections on record drawings shall be done in red ink. Record drawings shall be a control set of the construction plans kept on the site for daily recording of “as built” conditions. Show dimensioned locations of all buried facilities, such as drains, sumps, pipe, valves, electrical conduits, and irrigation wires.

Dimensions must be taken from above ground permanent architectural objects, not plants or irrigation heads. All dimensions, notes, etc., shall be legible.

Record drawings shall be reviewed prior to all progress payment requests, and submitted prior to final inspection.”

**D. COMPLETION OF WORK:**

(1) All work to be done under this contract shall be completed within Thirty (30) **consecutive working days**, exclusive of maintenance periods, beginning on the date stipulated in the written "Notice to Proceed" issued by the Engineer.

(2) In the event that the Engineer is of the opinion that the work is being inadequately or improperly prosecuted in any respect, he or she may demand that the Contractor improve or change the prosecution of the work in such manner as to assure proper and timely completion.

**E. FINAL INVOICE AND PAYMENT:**

(1) Whenever in the opinion of the Engineer the Contractor shall have completely performed the contract on his or her part, the Engineer shall notify the District that the contract has been completed in its entirety. He or she shall request that the District accept the work and that the District of the Board be authorized to file, on behalf of the District, in the office of the Ventura County Recorder, a notice of completion of the work herein

agreed to be done by the Contractor. The Contractor will then submit to the Engineer for approval a written statement of the final quantities of contract items for inclusion in the final invoice. Upon receipt of such statement, the Engineer shall check the quantities included therein and shall authorize the Contractor to submit an invoice which in the Engineer's opinion shall be just and fair, covering the amount and value of the total amount of work done by the Contractor, not including the work that has already been invoiced by the Contractor. District will pay this invoice less any amounts District is required to withhold as described elsewhere in the Contract Documents.

(2) On the expiration of sixty (60) calendar days after recordation of the acceptance of the project by Ventura County Recorder, the District shall pay to the Contractor the amount remaining after deducting from the amount or value stated in the invoice all prior payments to the Contractor and all amounts to be kept and retained under the provisions of the contract and 150% of all disputed amounts, and shall release the faithful performance bond and the labor and material bond once all applicable disputes have been resolved. The District will comply with Public Contract Code Section 7107 and other applicable law regarding the release of retention.

**F. RETENTION:** The District will deduct a five percent (5%) retention from all progress payments as specified in Section 7-3.2 of the 2021 Standard Specifications for Public Works Construction.

**G. SUBSTITUTION OF SECURITIES FOR RETENTION:** Public Contract Code Section 22300 is hereby incorporated by reference. The substitution of securities for any moneys withheld by a public agency to ensure performance under a contract shall be permitted by the District.

**H. NO PERSONAL LIABILITY:** No agent of the Pleasant Valley Recreation & Park District shall be personally responsible for any liability arising under the contract. No claim shall be made or filed, and neither the District nor any of its agents shall be liable for, or held to pay money, except as specifically provided in the contract.

**I. UNPAID CLAIMS:** If, upon or before the completion of the work herein agreed to be performed or at any time prior to the expiration of the period within which claims of lien may be filed for record as prescribed by Civil Code Section 8416, any person or persons claiming to have performed any labor or furnished any material, supplies, or services toward the performance or completion of this contract or that they have agreed to do so, shall file with the District a verified statement of such claim, stating in general terms the kind of labor and materials and the name of the person to or for whom the same was done or furnished, or both, and the amount in value, as near as may be, of that already done or furnished, or both, together with a statement that the same has not been paid, or if any person or persons shall bring against the District or against any agent or agents thereof any action to enforce such claim, the District shall until the discharge thereof withhold from the moneys under its control so much of said moneys due or to become due the Contractor under this contract as shall be sufficient to satisfy and discharge the amount in such notice or under such action claimed to be due, together with the costs thereof; provided, that if the District shall in its discretion permit the Contractor to file such additional bond as is authorized by



Civil Code Section 9364 in a sum equal to 125% of the amount of the claim, said moneys shall not thereafter be withheld on account of such claim.

**J. ADDITIONAL SURETY:** If during the continuance of the contract any of the sureties upon the faithful performance bond in the opinion of the Engineer are or become insufficient, he or she may require additional sufficient sureties which the Contractor shall furnish to the satisfaction of the Engineer within fifteen (15) days after notice and, in default thereof, the contract may be suspended and the work completed as provided in Section 6 of the Standard Specifications.

**K. NOISE CONTROL REQUIREMENTS:** The Contractor shall comply with all local sound control and noise level rules, regulations, and ordinances that apply to any work performed pursuant to the contract.

Each internal combustion engine, used for any purpose on the job or related to the job, shall be equipped with a muffler of a type recommended by the manufacturer. No internal combustion engine shall be operated on the project without said muffler. The noise level from the Contractor's operations, between the hours of 7:00 A.M. and 5:00 P.M., shall not exceed 86 dBA at a distance of fifty (50) feet. This requirement in no way relieves the Contractor from responsibility for complying with the District Code Chapter 8.20 "Noise Control" regulating noise level. Said noise level requirements shall apply to all equipment on the job or related to the job, including but not limited to trucks, transmit mixers, or transient equipment that may or may not be owned by the Contractor. The use of loud sound signals shall be avoided in favor of light warnings except those required by safety laws for the protection of personnel.

Full compensation for conforming to the requirements of this section shall be considered as included in the unit cost for the various contract items of work involved, and no additional compensation will be allowed therefor.

**L. PERMITS AND LICENSES:** The Contractor shall procure all permits and licenses, pay all charges and fees, and give all notices necessary and incident to the due and lawful prosecution of the work. The Contractor shall also ensure that all subcontractors obtain required permits and licenses.

The Environmental Quality Act of 1970 (Chapter 1433, Stats. 1970), as amended by Chapter 1154, Stats. 1972, may be applicable to permits, licenses, and other authorizations which the Contractor must obtain from local agencies in connection with performing the work of the contract. The Contractor shall comply with all applicable environmental laws and regulations and conditions on the project in obtaining such permits, licenses, and other authorizations, and they shall be obtained in sufficient time to prevent delays to the work, and in undertaking the construction of the project. Contractor shall also comply with all applicable mandatory standards and policies relating to energy efficiency.

In the event that the District has obtained permits, licenses, or other authorizations applicable to the work in conformance with the requirements in said Environmental Quality Act of 1970, the Contractor shall comply with the provisions of said permits, licenses, and other authorizations.

**M. PAYMENTS:** Attention is directed to Subsection 7-3.2 of the Standard Specifications for partial payment and final payment requirements. No partial payment will be made for any materials on hand which are furnished but not incorporated in the work.

**N. LEGAL ACTIONS AGAINST THE DISTRICT:** In the event litigation is brought against the District concerning compliance by the District with State or Federal laws, rules, or regulations applicable to highway work, the provisions of this section shall apply.

(1) If, pursuant to court order, the District prohibits the Contractor from performing all or any portion of the work, the delay will be considered a utility delay within the meaning of Subsection 4-2.5 of the Standard Specifications unless the contract is terminated as hereinafter provided, in which event compensation payable to the Contractor shall be determined in accordance with said termination provisions.

(2) If, pursuant to court order (other than an order to show cause) the District is prohibited from requiring the Contractor to perform all or any portion of the work, the District may, if it so elects, eliminate the enjoined work pursuant to Section 2-7 of the Standard Specifications or terminate the contract in accordance with Subsections 6-6 and 6-7 of the Standard Specifications.

(3) If the final judgment in the action prohibits the District from requiring the Contractor to perform all or any portion of the work, the District will either eliminate the enjoined work pursuant to Section 2-7 of the Standard Specifications or terminate the contract in accordance with Subsections 6-6 and 6-7 of the Standard Specifications.

(4) Termination of the contract and the total compensation payable to the Contractor in the event of termination shall be governed by the following:

(a) The Engineer will issue the Contractor a written notice specifying that the contract is to be terminated. Upon receipt of said written notice and, except as otherwise directed in writing by the Engineer, the Contractor shall:

[1] Stop all work under the contract, except that portion of the work specifically directed to be completed prior to acceptance.

[2] Perform work the Engineer deems necessary to secure the project for termination.

[3] Remove equipment and plan from the site of the work.

[4] Take such action as is necessary to protect materials from damage.

[5] Notify all Subcontractors and suppliers that the contract is being terminated and that their contracts or orders are not to be further performed unless otherwise authorized in writing by the Engineer.

[6] Provide the Engineer with an inventory list of all materials previously produced, purchased, or ordered from suppliers for use in the work and not yet used in the work, including its storage location and such other information as the Engineer may request.

[7] Dispose of materials not yet used in the work as directed by Engineer. It shall be the Contractor's responsibility to provide the District with good title to all materials purchased by the District hereunder, including materials for which partial payment has been made as provided in Subsection 7-3.2 of the Standard Specifications, and with bills of sale or other documents of title for such materials.

[8] Subject to the prior written approval of the Engineer, settle all outstanding liabilities and all claims arising out of subcontracts or orders for materials terminated hereunder. To the extent directed by the Engineer, the Contractor shall assign to the District all the right, title, and interest of the Contractor under subcontracts or orders for materials terminated hereunder.

[9] Furnish the Engineer with the documentation required to be furnished by the Contractor under the provisions of the contract including, on projects as to which Federal funds are involved, all documentation required under the Federal requirements included in the contract.

[10] Take such other actions as the Engineer may direct.

(b) Acceptance of the contract as hereinafter specified shall not relieve the Contractor of responsibility for damage to materials except as follows:

[1] The Contractor's responsibility for damage to materials for which partial payment has been made as provided in Subsection 7-3.2 of the Standard Specifications, and for materials furnished by the District for use in the work and unused, shall terminate when the Engineer certifies that such materials have been stored in the manner and at the locations he or she has directed.

[2] The Contractor's responsibility for damage to materials purchased by the District subsequent to the issuance of the notice that the contract is to be terminated shall terminate when title and delivery of the materials has been taken by the District.

[3] When the Engineer determines that the Contractor has completed the work under the contract directed to be completed prior to termination and such other work as may have been ordered to secure the project for termination, he or she will recommend that the Engineer formally accept the contract, and immediately upon and after such acceptance by the

Engineer, the Contractor will not be required to perform any further work thereon and shall be relieved of his or her contractual responsibilities for injury to persons or property which occurs after the formal acceptance of the project by the Engineer.

(c) The total compensation to be paid to the Contractor shall be determined by the Engineer on the basis of the following:

[1] The reasonable cost to the Contractor, without profit, for all work performed under the contract, including mobilization, demobilization, and work done to secure the project for termination. Reasonable cost will include a reasonable allowance for project overhead and general administrative overhead not to exceed a total of seven percent (7%) of direct costs of such work.

When in the opinion of the Engineer, the cost of a contract item of work is excessively high due to costs incurred to remedy or replace defective or rejected work, the reasonable cost to be allowed will be the estimated reasonable cost of performing such work in compliance with the requirements of the plans and specifications and the excessive actual cost shall be disallowed.

[2] A reasonable allowance for profit on the cost of the work performed as determined under Subsection (a), provided the Contractor establishes to the satisfaction of the Engineer that it is reasonably probable that he or she would have made a profit had the contract been completed and provided further that the profit allowed shall in no event exceed four percent (4%) of said cost.

[3] The reasonable cost to the Contractor of handling material returned to the vendor, delivered to the District, or otherwise disposed of as directed by the Engineer.

[4] A reasonable allowance for the Contractor's administrative costs in determining the amount payable due to termination of the contract.

All records of the Contractor and his or her subcontractors, necessary to determine compensation in accordance with the provisions of this section, shall be open to inspection or audit by representatives of the District at all times after issuance of the notice that the contract is to be terminated and for a period of three years, and such records shall be retained for that period.

After acceptance of the work by the Engineer, the Engineer may make payments on the basis of interim estimates pending issuance of the Final Estimate when in his or her opinion the amount thus paid, together with all amounts previously paid, will not result in total compensation in excess of

that to which the Contractor will be entitled. All payments, including payment upon the Final Estimate, shall be subject to deduction for prior payments and amounts, if any, to be kept or retained under the provisions of the contract.

The provisions of this section shall be included in all subcontracts.

**O. TRENCHING:** In accordance with Section 6705 of the California Labor Code,

No contract for public works involving an estimated expenditure in excess of twenty-five thousand dollars (\$25,000), for the excavation of any trench or trenches five feet or more in depth, shall be awarded unless it contains a clause requiring submission by the Contractor and acceptance by the awarding body or by a registered civil or structural engineer employed by the awarding body, to whom authority to accept has been delegated, in advance of excavation, of a detailed plan showing the design of shoring, bracing, sloping, or other provisions to be made for worker protection from the hazard of caving ground during the excavation of such trench or trenches. If such plan varies from the shoring system standards, the plan shall be prepared by a registered civil or structural engineer.

Nothing in this section shall be deemed to allow the use of a shoring, sloping, or protective system less effective than that required by the Construction Safety Orders.

Nothing in this section shall be construed to impose tort liability on the awarding body or any of its employees.

The terms "public works" and "awarding body," as used in this section, shall have the same meaning as in Sections 1720 and 1722, respectively, of the Labor Code."

In addition, pursuant to Public Contracts Code § 7104, if the project involves digging trenches or other excavations that extend deeper than four feet below the surface:

(a) That the contractor shall promptly, and before the following conditions are disturbed, notify the local public entity, in writing, of any:

(1) Material that the contractor believes may be material that is hazardous waste, as defined in Section 25117 of the Health and Safety Code, that is required to be removed to a Class I, Class II, or Class III disposal site in accordance with provisions of existing law.

(2) Subsurface or latent physical conditions at the site differing from those indicated by information about the site made available to bidders prior to the deadline for submitting bids.

(3) Unknown physical conditions at the site of any unusual nature, different materially from those ordinarily encountered and generally recognized as inherent in the work of the character provided for in the contract.

(b) That the local public entity shall promptly investigate the conditions, and if it finds that the conditions do materially so differ, or do involve hazardous waste, and cause a decrease or increase in the contractor's cost of, or the time required for, performance of any part of the work shall issue a change order under the procedures described in the contract.

(c) That, in the event that a dispute arises between the local public entity and the contractor whether the conditions materially differ, or involve hazardous waste, or cause a decrease or increase in the contractor's cost of, or time required for, performance of any part of the work, the contractor shall not be excused from any scheduled completion date provided for by the contract, but shall proceed with all work to be performed under the contract. The contractor shall retain any and all rights provided either by contract or by law which pertain to the resolution of disputes and protests between the contracting parties."

Full compensation for sheeting, shoring, bracing, sloping, and all other provisions required for worker protection shall be considered as included in the contract price shown in the appropriate Bid Item, and no additional compensation will be allowed therefor.

**P. CHANGES IN WORK:**

The following Section is hereby added:

"7.4.3.3 Mark-up Cap. Work by the Subcontractor the Contractor's total mark-up is not to exceed 12%."

**Q. CONTROL OF MATERIALS:**

The following sections are added to Section 4:

"4-1.1 General. The Contractor and all subcontractors, suppliers, and vendors shall guarantee that all work performed under this contract fully meets the requirements thereof as to quality of workmanship. Should any defects become evident within a period of one year from the date of the acceptance of the work by the District's Board, the Contractor shall, at his or her own expense, make any repair or replacement necessary to restore the work to full compliance with these Special Provisions.

Such repair and replacement shall be made promptly upon receipt of written notice from the Engineer. If the Contractor fails to make such repair and replacement promptly, the Engineer may cause the work to be done and the costs incurred thereby shall become the liability of the Contractor and his or her Surety.

If, in the opinion of the Engineer, defective work creates a dangerous condition or requires immediate correction or attention to prevent further loss by the District or to prevent interruption of operations of the District, the District will attempt to give the notice required by this article. If the Contractor cannot be contacted or does not comply with the Engineer's request for correction within a reasonable time as

determined by the Engineer, the District may, notwithstanding the provisions of this article, proceed to make such correction or attention and the costs of such correction or attention shall be charged against the Contractor.

The foregoing obligation shall be secured by the surety bond in a form approved by the Engineer in an amount not less than ten (10%) of the final contract price or \$1,000.00, whichever is greater, and shall be delivered to the Engineer prior to final acceptance of the work. Payment for fulfilling the requirements of this section shall be considered as included in the unit cost for the various contract items of work, and no additional compensation will be allowed therefor.”

“4-4.1 Test of Materials. Except as elsewhere specified, the District will bear the cost of testing material and/or workmanship that meets or exceeds the requirements indicated in the project specifications contained herein, Standard Specifications and the Special Provisions. The cost of all other tests, including the retesting of material or workmanship that fails to pass the first test, shall be borne by the Contractor.”

Section 4-5 shall be replaced with the following:

“4-5 Certification. A Certificate of Compliance shall be furnished prior to the use of any materials for which these specifications or the special provisions require that such a certificate be furnished. In addition, when so authorized in these specifications or in the Special Provisions, the Engineer may permit the use of certain materials or assemblies prior to sampling and testing if accompanied by a Certificate of Compliance. The certificate shall be signed by the manufacturer of the material or the manufacturer of assembled materials and shall state that the materials involved comply in all respects with the requirements of the specifications. A Certificate of Compliance shall be furnished with each lot of material delivered to the work and the lot so certified shall be clearly identified in the certificate.”

**R. CARB Compliance.** For a project involving the use of in-use off-road diesel-fueled vehicles, as defined by 13 CCR 2449, Contractor shall obtain copies of the valid Certificates of Reported Compliance, as described in 13 CCR 2449(n), for the fleet performing services pursuant to this contract and all listed subcontractors, if applicable, prior to commencing any work pursuant to this Contract or any renewed contract with that fleet. Contractor shall indemnify, defend and hold harmless the District, its officers, agents, employees and directors from any liability imposed arising from Contractor’s violation of any regulation set forth in 13 CCR 2449.

**S. CONFERENCES AND MEETING:** When and as directed by the Engineer, the Contractor shall attend all conferences and meetings that the Engineer deems necessary for the proper progress of work under this contract.

**T. UNDERGROUND SERVICE ALERT:** Except in an emergency, the Contractor, prior to conducting any excavation or resurfacing, shall contact the appropriate regional notification

center, at least two working days prior to commencing that excavation or resurfacing. The regional notification center shall provide an inquiry center and shall notify any member, if known, who has a subsurface installation in the area of the proposed excavation or resurfacing.

Underground Service Alert may be contacted by calling 1-800-422-4133.

**U. RESOLUTION OF ALL CONSTRUCTION CLAIMS:**

**“9204. Legislative findings and declarations regarding timely and complete payment of contractors for public works projects; claims process**

(a) The Legislature finds and declares that it is in the best interests of the state and its citizens to ensure that all construction business performed on a public works project in the state that is complete and not in dispute is paid in full and in a timely manner.

(b) Notwithstanding any other law, including, but not limited to, Article 7.1 (commencing with Section 10240) of Chapter 1 of Part 2, Chapter 10 (commencing with Section 19100) of Part 2, and Article 1.5 (commencing with Section 20104) of Chapter 1 of Part 3, this section shall apply to any claim by a contractor in connection with a public works project.

(c) For purposes of this section:

(1) “Claim” means a separate demand by a contractor sent by registered mail or certified mail with return receipt requested, for one or more of the following:

(A) A time extension, including, without limitation, for relief from damages or penalties for delay assessed by a public entity under a contract for a public works project.

(B) Payment by the public entity of money or damages arising from work done by, or on behalf of, the contractor pursuant to the contract for a public works project and payment for which is not otherwise expressly provided or to which the claimant is not otherwise entitled.

(C) Payment of an amount that is disputed by the public entity.

(2) “Contractor” means any type of contractor within the meaning of Chapter 9 (commencing with Section 7000) of Division 3 of the Business and Professions Code who has entered into a direct contract with a public entity for a public works project.

(3)(A) “Public entity” means, without limitation, except as provided in subparagraph (B), a state agency, department, office, division, bureau, board, or commission, the California State University, the University of California, a city, including a charter city, county, including a charter county, city and county, including a charter city and county, district, special district, public authority, political subdivision, public corporation, or nonprofit transit corporation wholly owned by a public agency and formed to carry out the purposes of the public agency.

(B) “Public entity” shall not include the following:

(i) The Department of Water Resources as to any project under the jurisdiction of that department.



(ii) The Department of Transportation as to any project under the jurisdiction of that department.

(iii) The Department of Parks and Recreation as to any project under the jurisdiction of that department.

(iv) The Department of Corrections and Rehabilitation with respect to any project under its jurisdiction pursuant to Chapter 11 (commencing with Section 7000) of Title 7 of Part 3 of the Penal Code.

(v) The Military Department as to any project under the jurisdiction of that department.

(vi) The Department of General Services as to all other projects.

(vii) The High-Speed Rail Authority.

(4) "Public works project" means the erection, construction, alteration, repair, or improvement of any public structure, building, road, or other public improvement of any kind.

(5) "Subcontractor" means any type of contractor within the meaning of Chapter 9 (commencing with Section 7000) of Division 3 of the Business and Professions Code who either is in direct contract with a contractor or is a lower tier subcontractor.

(d)(1)(A) Upon receipt of a claim pursuant to this section, the public entity to which the claim applies shall conduct a reasonable review of the claim and, within a period not to exceed 45 days, shall provide the claimant a written statement identifying what portion of the claim is disputed and what portion is undisputed. Upon receipt of a claim, a public entity and a contractor may, by mutual agreement, extend the time period provided in this subdivision.

(B) The claimant shall furnish reasonable documentation to support the claim.

(C) If the public entity needs approval from its governing body to provide the claimant a written statement identifying the disputed portion and the undisputed portion of the claim, and the governing body does not meet within the 45 days or within the mutually agreed to extension of time following receipt of a claim sent by registered mail or certified mail, return receipt requested, the public entity shall have up to three days following the next duly publicly noticed meeting of the governing body after the 45-day period, or extension, expires to provide the claimant a written statement identifying the disputed portion and the undisputed portion.

(D) Any payment due on an undisputed portion of the claim shall be processed and made within 60 days after the public entity issues its written statement. If the public entity fails to issue a written statement, paragraph (3) shall apply.

(2)(A) If the claimant disputes the public entity's written response, or if the public entity fails to respond to a claim issued pursuant to this section within the time prescribed, the claimant may demand in writing an informal conference to meet and confer for settlement of the issues in dispute. Upon receipt of a demand in writing sent by registered mail or certified mail, return receipt requested, the public entity shall schedule a meet and confer conference within 30 days for settlement of the dispute.

(B) Within 10 business days following the conclusion of the meet and confer conference, if the claim or any portion of the claim remains in dispute, the public entity shall provide the claimant a written statement identifying the portion of the claim that remains in dispute and the portion that is undisputed. Any payment due on an undisputed portion of the claim shall be processed and made within 60 days after the public entity issues its written statement. Any disputed portion of the claim, as identified by the contractor in writing, shall be submitted to nonbinding mediation, with the public entity and the claimant sharing the associated costs equally. The public entity and claimant shall mutually agree to a mediator within 10 business days after the disputed portion of the claim has been identified in writing. If the parties cannot agree upon a mediator, each party shall select a mediator, and those mediators shall select a qualified neutral third party to mediate with regard to the disputed portion of the claim. Each party shall bear the fees and costs charged by its respective mediator in connection with the selection of the neutral mediator. If mediation is unsuccessful, the parts of the claim remaining in dispute shall be subject to applicable procedures outside this section.

(C) For purposes of this section, mediation includes any nonbinding process, including, but not limited to, neutral evaluation or a dispute review board, in which an independent third party or board assists the parties in dispute resolution through negotiation or by issuance of an evaluation. Any mediation utilized shall conform to the timeframes in this section.

(D) Unless otherwise agreed to by the public entity and the contractor in writing, the mediation conducted pursuant to this section shall excuse any further obligation under Section 20104.4 to mediate after litigation has commenced.

(E) This section does not preclude a public entity from requiring arbitration of disputes under private arbitration or the Public Works Contract Arbitration Program, if mediation under this section does not resolve the parties' dispute.

(3) Failure by the public entity to respond to a claim from a contractor within the time periods described in this subdivision or to otherwise meet the time requirements of this section shall result in the claim being deemed rejected in its entirety. A claim that is denied by reason of the public entity's failure to have responded to a claim, or its failure to otherwise meet the time requirements of this section, shall not constitute an adverse finding with regard to the merits of the claim or the responsibility or qualifications of the claimant.

(4) Amounts not paid in a timely manner as required by this section shall bear interest at 7 percent per annum.

(5) If a subcontractor or a lower tier subcontractor lacks legal standing to assert a claim against a public entity because privity of contract does not exist, the contractor may present to the public entity a claim on behalf of a subcontractor or lower tier subcontractor. A subcontractor may request in writing, either on their own behalf or on behalf of a lower tier subcontractor, that the contractor present a claim for work which was performed by the subcontractor or by a lower tier subcontractor on behalf of the subcontractor. The subcontractor requesting that the claim be

presented to the public entity shall furnish reasonable documentation to support the claim. Within 45 days of receipt of this written request, the contractor shall notify the subcontractor in writing as to whether the contractor presented the claim to the public entity and, if the original contractor did not present the claim, provide the subcontractor with a statement of the reasons for not having done so.

(e) The text of this section or a summary of it shall be set forth in the plans or specifications for any public works project that may give rise to a claim under this section.

(f) A waiver of the rights granted by this section is void and contrary to public policy, provided, however, that (1) upon receipt of a claim, the parties may mutually agree to waive, in writing, mediation and proceed directly to the commencement of a civil action or binding arbitration, as applicable; and (2) a public entity may prescribe reasonable change order, claim, and dispute resolution procedures and requirements in addition to the provisions of this section, so long as the contractual provisions do not conflict with or otherwise impair the timeframes and procedures set forth in this section.

(g) This section applies to contracts entered into on or after January 1, 2017.

(h) Nothing in this section shall impose liability upon a public entity that makes loans or grants available through a competitive application process, for the failure of an awardee to meet its contractual obligations.

(i) This section shall remain in effect only until January 1, 2027, and as of that date is repealed, unless a later enacted statute that is enacted before January 1, 2027, deletes or extends that date.”

#### **RESOLUTION OF CONSTRUCTION CLAIMS OF \$375,000 OR LESS:**

##### **“20104. Application of article; provisions included in plans and specifications**

(a) (1) This article applies to all public works claims of three hundred seventy-five thousand dollars (\$375,000) or less which arise between contractor and a local agency.

(2) This article shall not apply to any claims resulting from a contract between a contractor and a public agency when the public agency has elected to resolve any disputes pursuant to Article 7.1 (commencing with Section 10240) of Chapter 1 of Part 2.

(b) (1) "Public work" means "public works contract" as defined in Section 1101 but does not include any work or improvement contracted for by the State or the Regents of the University of California.

(2) "Claim" means a separate demand by the contractor for (A) a time extension, (B) payment of money or damages arising from work done by or on behalf of, the contractor pursuant to the contract for a public work and payment of which is not otherwise expressly provided for or the claimant is not otherwise entitled to, or (C) an amount the payment of which disputed by the local agency.

(c) The provisions of this article or a summary thereof shall be set forth in the plans or specifications for any work which may give rise to a claim under this article.

(d) This article applies only to contracts entered into on or after January 1, 1991.”

**“20104.2. Claims; requirements; tort claims excluded**

For any claim subject to this article, the following requirements apply:

(a) The claim shall be in writing and include the documents necessary to substantiate the claim. Claims must be filed on or before the date of final payment. Nothing in this subdivision is intended to extend the time limit or supersede notice requirements otherwise provided by contract for the filing of claims.

(b) (1) For claims of less than fifty thousand dollars (\$50,000), the local agency shall respond in writing to any written claim within 45 days of receipt of the claim, or may request, in writing, within 30 days of receipt of the claim, any additional documentation supporting the claim or relating to defenses to the claim the local agency may have against the claimant.

(2) If additional information is thereafter required, it shall be requested and provided pursuant to this subdivision, upon mutual agreement of the local agency and the claimant.

(3) The local agency's written response to the claim, as further documented, shall be submitted to the claimant within 15 days after receipt of the further documentation or within a period of time no greater than that taken by the claimant in producing the additional information, whichever is greater.

(c) (1) For claims of over fifty thousand dollars (\$50,000) and less than or equal to three hundred seventy-five thousand dollars (\$375,000), the local agency shall respond in writing to all written claims within 60 days of receipt of the claim, or may request, in writing, within 30 days of receipt of the claim, any additional documentation supporting the claim or relating to defenses to the claim the local agency may have against the claimant.

(2) If additional information is thereafter required, it shall be requested and provided pursuant to this subdivision, upon mutual agreement of the local agency and the claimant.

(3) The local agency's written response to the claim, as further documented, shall be submitted to the claimant within 30 days after receipt of the further documentation, or within a period of time no greater than that taken by the claimant in producing the additional information or requested documentation, whichever is greater.

(d) If the claimant disputes the local agency's written response, or the local agency fails to respond within the time prescribed, the claimant may so notify the local agency, in writing, either within 15 days of receipt of the local agency's response or within 15 days of the local agency's failure to respond within the time prescribed, respectively, and demand an informal conference to

meet and confer for settlement of the issues in dispute. Upon a demand, the local agency shall schedule a meet and confer conference within 30 days for settlement of the dispute.

(e) Following the meet and confer conference the claim or any portion remains in dispute, the claimant may file a claim as provided in Chapter 1 (commencing with Section 900) and Chapter 2 (commencing with Section 910) of Part 3 of Division 3.6 of Title 1 of the Government Code. For purposes of those provisions, the running of the period of time within which a claim must be filed shall be tolled from the time the claimant submits his or her written claim pursuant to subdivision (a) until the time that claim is denied as a result of the meet and confer process, including any period of time utilized by the meet and confer process.

(f) This article does not apply to tort claims and nothing in this article is intended nor shall be construed to change the time periods for filing tort claims or actions specified by Chapter 1 (commencing with Section 900) and Chapter 2 (commencing with Section 910) of Part 3 of Division 3.6 of Title 1 of the Government Code.”

**“20104.4. Civil action procedures; mediation and arbitration; trial de novo; witnesses**

The following procedures are established for all civil actions filed to resolve claims subject to this article:

(a) Within 60 days, but no earlier than 30 days, following the filing or responsive pleadings, the court shall submit the matter to nonbinding mediation unless waives by mutual stipulation of both parties. The mediation process shall provide for the selection within 15 days by both parties of a disinterested third person as mediator, shall be commenced within 30 days of the submittal, and shall be concluded within 15 days from the commencement of the mediation unless a time requirement is extended upon a good cause showing to the court or by stipulation of both parties. If the parties fail to select a mediator within the 15-day period, any party may petition the court to appoint the mediator.

(b) (1) If the matter remains in dispute, the case shall be submitted to judicial arbitration pursuant to Chapter 2.5 (commencing with Section 1141.10) of Title 3 of Part 3 of the Code of Civil Procedure, notwithstanding Section 1141.11 of that code. The Civil Discovery Act (Title 4 (commencing with Section 2016.010), of the Code of Civil Procedure) shall apply to any proceeding brought under this subdivision consistent with the rules pertaining to judicial arbitration.

(2) Notwithstanding any other provision of law, upon stipulation of the parties, arbitrators appointed for purposes of this article shall be experienced in construction law, and, upon stipulation of the parties, mediators and arbitrators shall be paid necessary and reasonable hourly rates of pay not to exceed their customary rate, and such fees and expenses shall be paid equally by the parties, except in the case of arbitration where the arbitrator, for good cause, determines a different division. In no event shall these fees or expenses be paid by state or county funds.

(3) In addition to Chapter 2.5 (commencing with Section 1141.10) of Title 3 of Part 3 of the Code of Civil Procedure, any party who after receiving an arbitration award requests a trial de novo but does not obtain a more favorable judgment shall, in addition to payment of costs and fees under that chapter, pay the attorney's fees of the other party arising out of trial de novo.

(c) The court may, upon request by any party, order any witnesses to participate in the mediation or arbitration process.”

**“20104.6. Payment on undisputed portion of claim; interest on arbitration award or judgment**

(a) No local agency shall fail to pay money as to any portion of a claim which is undisputed except as otherwise provided in the contract.

(b) In any suit filed under Section 20104.4, the local agency shall pay interest at the legal rate on any arbitration award or judgment. The interest shall begin to accrue on the date the suit is filed in a court of law.”

**W. WORKING HOUR RESTRICTIONS:** Eight hours’ labor is a legal day’s work. Any workers time of service is restricted to eight hours during any calendar day and forty hours during any calendar week, unless overtime compensation is paid at not less than one and one-half times the basic rate of pay. The Contractor or Subcontractor shall, as a penalty to the District forfeit twenty-five dollars (\$25) for each worker employed in the execution of the contract by the respective Contractor or subcontractor for each calendar day during which the worker is required or permitted to work more than eight hours in any one calendar day and forty hours in any one calendar week in violation of the law.

**X. EXAMINATION AND AUDIT:** All documents and records that relate in any way to this Agreement shall be maintained for a period of three years after the final payment under this Agreement. These records shall be subject to the examination and audit by the District and by the State Auditor, at the request of the District or as part of any audit of the District, for a period of three years after final payment under the Agreement.

**Y. DELAYS AND EXTENSIONS OF TIME**

6-4.4 Written Notice and Report. The first sentence of subsection 6-6.4 is hereby deleted and replaced with the following:

“If the Contractor desires payment for a delay as specified in Subsection 6-6.3 of the Standard Specifications, it shall notify the Engineer in writing within 3 days of the beginning of the delay. If the Contractor desires an extension of time as specified in Subsection 6-4.2 of the Standard Specifications, it shall notify the Engineer in writing within 3 days of the beginning of the delay. Such notice shall specify the nature of the delay, cause, and the conditions that set the beginning time for the delay.”

## **Z. PROTECTION AND RESTORATION OF EXISTING IMPROVEMENTS**

The second paragraph of Subsection 400-1 of the Standard Specifications is hereby deleted and replaced with the following:

“The Contractor shall relocate, repair, replace, or reestablish all existing improvements within the project area which are not designated for removal (e.g., curbs, sidewalks, driveways, fences, walls, sprinkler systems, signs, utility installations, pavements, structures, etc.) which are damaged or removed as a result of his or her operations or as required by the Plans and Specifications.

Where existing traffic striping, pavement markings, and curb markings are damaged or their reflectivity reduced by the Contractor's operations, such striping or markings shall also be considered as existing improvements and the Contractor shall repaint or replace such improvements.

Relocations, repairs, replacements, or reestablishments shall be at least equal to the existing improvements and shall match such improvements in finish and dimensions unless otherwise specified.”

Subsection 400-1.1 of the Standard Specifications is hereby added to read as follows:

“All costs to the Contractor for protecting, removing, restoring, relocating, repairing, replacing, or reestablishing existing improvements shall be included in the unit cost for the various items of work and no additional compensation will be allowed therefore.”

## **2. PUBLIC CONVENIENCE AND SAFETY**

**A. GENERAL:** In addition to the requirements specified in Part 6 of the Standard Specifications, traffic control shall conform to the provisions of the latest edition of the State of California, Department of Transportation, "Manual of Traffic Controls."

The Contractor shall give a one-week advance notice prior to the start of construction to all residences and businesses facing or siding on the construction area. Said notice shall be in writing on the Contractor's letterhead and shall explain in concise terms the extent and nature of the Work, the anticipated schedule, and office and emergency telephone numbers where the Contractor's representative can be reached.

Should the Contractor appear to be neglectful or negligent in furnishing warning and protective measures, the Engineer may direct attention to the existence of a hazard and the necessary warning and protective measures shall be furnished and installed immediately by the Contractor at his or her expense.

Should the Engineer point out the inadequacy of warning and protective measures, such action on the part of the Engineer shall not relieve the Contractor from responsibility for public safety or abrogate his or her obligation to furnish and pay for these devices.

If the Contractor cannot be contacted or if attention is directed to the existence of a hazard and the Contractor fails to provide the necessary safety devices, said devices will be placed, or caused to be placed, by the District. The cost of placement to these devices shall be the sole responsibility of the Contractor and shall be paid for at the rate of \$50 per call-out plus \$25 per traffic control device for each 24 hours, or fraction thereof, that the device is required. Said costs shall be deducted from the total contract price for the work.

Prior to beginning any construction, the Contractor shall furnish the Engineer with local emergency phone numbers where he or she or a representative may be contacted during non-working hours or days for the purpose of replacing or providing additional warning or safety devices as directed by the Engineer.

**B. UTILITIES:** It is anticipated that the existing utilities will not interfere with the Contractor's construction operations. However, the Contractor shall exercise due care to ensure that the utility facilities are not damaged during his or her operations, and must notify utilities and obtain an identification number before excavation or be subject to liability for damages to subsurface installations. When in doubt, the Contractor shall contact the utility concerned before proceeding further.

Upon completion of the project, the Contractor shall be responsible to remove all painted utility markings, whether done by him or her or the respective utility owners on behalf of the contractor for this project work, from the surfaces of sidewalks, driveway approaches, curbs and gutters using the removal method acceptable to the Engineer. Any damage to sidewalks, driveway approaches, curbs and gutters due to the Contractor's removal operation shall be repaired at the Contractor's expense and to the satisfaction of the Engineer. Payment for removing utility markings shall be included in other items of work, and no additional compensation will be allowed therefore.

**C. LOCATION:** The location and existence of any underground utility or substructure, if shown on Plans, was obtained from a search of available records. No guarantee is made or implied that the information is complete or accurate. It shall be the Contractor's responsibility alone to determine the exact location of underground utilities or substructures of every nature and to protect them from damage. The Contractor shall excavate and expose all high-risk underground facilities.

The Contractor shall notify the owners of all utilities and substructures as set forth in the General Provisions.

**D. RELOCATION:** The second sentence of the last paragraph of Subsection 402-4 of the Standard Specifications is hereby deleted and replaced with the following:

“When not otherwise required by the Plans and Specifications and when directed by the Engineer, the Contractor shall arrange for the relocation of service connections, as necessary, between the meter and property line, or between the meter and limits of construction.

The Contractor shall be compensated for the costs of locating and repairing, removing and relocating utility facilities, provided that any damage is not due to the failure of the Contractor or



subcontractor to exercise reasonable care, and the utility facilities were not indicated in the plans and specifications with reasonable accuracy. The Contractor shall not be assessed liquidated damages for delay in completion of the project, when such delay was caused by the failure of the District or the owner of the utility to provide for removal or relocation of such utility facilities.”

**E. DELAYS:** The second paragraph of Subsection 402-5 is hereby deleted and replaced with the following two paragraphs:

“The Contractor will not be entitled to damages or additional payment for delays attributable to utility relocations or alterations if correctly located, noted and completed in accordance with Subsection 402-1. The Contractor shall ascertain further detailed information to coordinate his or her work to this effect.

All notification of utility companies shall be by the Engineer based on Contractor's request as submitted to the Engineer at least 72 hours in advance of the needed work. Any costs for delay of the Contractor or utility companies in this regard shall be assigned to the Contractor, if these costs are a result of the Contractor's request being untimely in any respect, except for the utility company not responding at their agreed time.”

**F. AIR POLLUTION CONTROL**

Section 3-12.2, "Air Pollution", of the Standard Specifications is supplemented by the following:

“The Contractor shall comply with all air pollution control rules, regulations, ordinances and statutes which apply to any work performed pursuant to the contract including any air pollution control, rules, regulations, ordinances and statutes specified in Section 11017 of the Government Code.

In the absence of any applicable air pollution control rules, regulations, ordinances or statutes governing solvents, all solvents, including but not limited to the solvent portions of paints, thinners, curing compounds, and liquid asphalt used on the project shall comply with the applicable material requirements of the County Air Pollution Control District. All containers of paint, thinner, curing compound or liquid asphalt shall be labeled to indicate that the contents fully comply with said requirements.”

**G. WATER POLLUTION:** The Contractor shall comply with the requirements of Subsection 3-12.6 of the Standard Specifications and shall conduct his or her operations so as to prevent portland cement, mud, silt or other materials from entering the surface drainage structures of the adjoining street and any underground storm drainage system.

Full compensation for prevention of water pollution and all required control work for preservation, clean-up and restoration of damaged property shall be considered as included in the unit cost for the various contract items of work, and no additional compensation will be allowed therefor.

**H. PROJECT APPEARANCE:** The Contractor shall maintain a neat appearance to the work.

Full compensation for conforming to the provisions of this section not otherwise provided for shall be considered as included in unit cost for the various contract items of work involved and no additional compensation will be allowed therefor.

**I. WORK HOURS:** The Contractor's working hours shall be limited to the hours between 7:00 a.m. and 5:00 p.m., excluding recognized holidays. Deviation from normal working hours will not be allowed without prior consent of the District Engineer.

In the event work is allowed by the Engineer outside of the normal working hours, at the request of and for the benefit of the Contractor, inspection service fees may be levied against the Contractor at a rate of \$50.00 per hour, including travel time where applicable. The above charge may also be levied if inspection services are deemed necessary by the Engineer as a matter of public safety or to otherwise insure the quality of the work.

**J. CONSTRUCTION YARD:** It shall be the Contractor's responsibility to locate any storage sites for materials and equipment needed and such sites must be approved in advance by the Engineer and must be free of objectionable material. The Contractor must submit to the Engineer for approval any and all agreement(s) between the Contractor and the property owner(s) of said storage site(s) and/or construction site(s) for approval prior to the start of construction. Said agreement(s) must provide for the restoration of the site(s) by the Contractor prior to the filing of "Notice of Completion" by the Engineer. Full compensation shall be considered as included in unit cost for the various contract items of work involved and no additional compensation will be allowed therefor.

No equipment or material used for staging shall be allowed to be stored on any District property or city streets during non-work time. All stage equipment and/or material shall be stored offsite and if such location is used, it shall be submitted in writing and approved by the District Engineer. All costs associated with such staging and location shall be included in other bid items of work and no additional compensation will be allowed thereof.

**K. SANITARY CONVENIENCE:** Necessary sanitary facilities for the use of the workmen performing the work, properly secluded from public observation and in compliance with health ordinances and laws, shall be constructed and maintained by Contractor, in a manner approved by the Engineer, and the use of such facilities shall be strictly enforced by the Contractor.

**L. INSPECTION:** The Engineer, or his or her authorized agent, shall at all times have access to work during construction and shall be furnished, to the extent possible, complete information and all documentation to ascertain full knowledge regarding the progress, workmanship and character of materials used and employed in the work. Whenever required, the Contractor shall furnish to the District for test, and free of charge, samples of any one of the materials proposed to be used in the work. Said samples shall be delivered by the Contractor at the place within the District designated by the Engineer. Rejected material must be immediately removed from the work by the Contractor and shall not again be brought back to the site of the improvement.

The Contractor shall notify the Engineer or his or her authorized agent forty-eight (48) hours in advance when he or she will require inspection for either material or work to be done.

The inspection of the work shall not relieve the Contractor of any of his or her obligations to fulfill the contract as prescribed. Defective work shall be made good, and unsuitable materials may be rejected, notwithstanding the fact that such defective work and unsuitable materials have been previously overlooked by the Engineer or his or her authorized agent and accepted or estimated for payment.

**M. RESPONSIBILITY OF THE DISTRICT:** The District shall not be held responsible for the care or protection of any material or parts of the work prior to final acceptance, except as expressly provided for in these Contract Documents.

**N. RECYCLING OF MATERIALS:** Contractor's Obligation. Recycling of asphalt concrete, portland cement concrete, aggregate base, and green waste (trees and shrubs) is required. The Contractor is required to recycle at least 50% of all recyclable materials. All recycled materials shall be weighed on a certified weigh scale with weight tickets showing project name. RECORDS OF DISPOSAL, INCLUDING WEIGHT OF MATERIALS, SHALL BE SUBMITTED TO THE DISTRICT ON A MONTHLY BASIS.

Prior to commencing work, the Contractor shall complete the "Construction and Demolition Waste Reduction and Recycling Plan" form and submit it to the Parks Department for review and approval. The Contractor will be expected to follow the approved Plan and document results during construction. At the completion of activities, the Contractor shall submit the "Construction and Demolition Waste Reduction and Recycling Report" form to the Public Works Department for review and approval of compliance with the Plans. The above-referenced forms are provided in Appendix 2.

The Contractor is obligated, under this contract, to recycle the waste material through an approved recycling plant. **In the event the Contractor fails to comply with the C&D requirements (at least 50%), three percent (3%) of the approved contract amount will be forfeited to the District by Contractor as a penalty.**

Payment for Recycling of Materials shall be included in the unit cost for the various contract items of work and no additional compensation will be allowed therefor.

**O. TRAFFIC AND ACCESS:** *The Contractor shall notify the occupants of all affected properties at least 48 hours prior to any temporary obstruction of access. Vehicular access to property line shall be maintained, except as required for construction for a reasonable period of time. No overnight closure of any driveway will be allowed, except as permitted by the Engineer. Temporary ramps for driveways shall be provided and maintained by the end of each working day and during the weekends. Temporary driveway ramps shall be constructed with crushed miscellaneous base as directed by the Engineer.*

Contractor shall maintain vehicular, bicycle, and pedestrian traffic access through the project area at all times. A minimum of one 12-foot wide traffic lane and a minimum of one 4-foot wide all-

weather paved pedestrian walkway shall be provided at all times, except as permitted by the Engineer. During times when less than 2 lanes of traffic are provided, contractors shall provide traffic control for the entire duration there is less than 2 lanes. The traffic lanes shall be maintained on all-weather pavement and shall remain unobstructed.

**P. STREET CLOSURES, DETOURS, BARRICADES, PARKING:**

- Street closures will NOT be allowed, except as specifically permitted by the Engineer.
- The Contractor shall prepare any traffic control or detour plans that may be required as directed by the Engineer.
- Lane transitions shall conform to the Caltrans Traffic Manual, Section 5-08.4, "Transition Area."
- Temporary traffic channelization shall be accomplished with delineators. Temporary striping will not be allowed unless specifically permitted by the Engineer. The Contractor shall prepare any plans that may be required for temporary striping to the satisfaction of the Engineer. In no event will temporary striping be allowed on finished pavement surfaces which are to remain.
- The Contractor shall schedule an employee to police the temporary delineators and barricades within the travel way during weekday, nonworking hours and over Saturdays, Sundays, and holidays. Any corrective work required to be done by District forces shall be back charged to the Contractor based on the actual costs, plus District overhead and withheld from the final payment.
- As specified in the General Provisions, the schedule shall be submitted to the Engineer for approval prior to commencing work. This schedule shall allow affected people ample "on-street" parking within a reasonable distance from their homes and businesses. Requests for changes in the schedule shall be made in accordance with the General Provisions.
- Temporary "No Parking" signs shall be posted at least 24 hours, but no more than 48 hours, in advance of the work. The signs shall be placed no more than 250 feet apart on each side of the street and at shorter intervals if conditions warrant. Signs shall be posted only for the areas necessary to accomplish the work. The Contractor shall provide the signs and will be responsible for adding the dates and hours of closure to the signs, removal of the signs, and furnishing and placing of barricades, if necessary, for posting of signs. All signs shall be removed within 48 hours after the effective date.
- Payment for STREET CLOSURES, DETOURS, BARRICADES, PARKING shall be considered as included in the unit cost for bid item: "Traffic Control" no additional compensation will be allowed therefor.

## TECHNICAL PROVISIONS

### PLEASANT VALLEY RECREATION & PARK DISTRICT

### PARKING LOT SLURRY SEALING PROJECT

#### SPEC NO. SSVPL-24-25

#### Locations:

- 1) Mel Vincent Park - 668 Calistoga Rd. Camarillo, CA. 93010
- 2) Pitts Ranch Park – 1400 Flynn Rd. Camarillo, CA. 93012
- 3) Pleasant Valley Fields – 200 Westpark Court, Camarillo, CA. 93012

#### Technical Specifications for Parking Lot Maintenance

##### 1. Crack Sealing (Cold Pour)

###### a. Materials:

- i. **Crack Sealant:** Cold-applied asphalt emulsion crack filler/sealant by GardTop® or approved equivalent.
- ii. **Primer:** If required, use an asphalt-based primer compatible with the crack sealant.

###### b. Equipment:

- i. Crack cleaning tools such as wire brushes or compressed air to remove debris
- ii. Pour pots or hand-held applicators for applying the sealant.
- iii. Squeegees to ensure even coverage.

###### c. Preparation:

- i. **Crack Cleaning:** Remove loose material, debris, and vegetation from the cracks using compressed air or hand tools
- ii. **Crack Drying:** Ensure the cracks are dry before applying sealant.

###### d. Application:

- i. **Temperature:** Apply sealant when pavement temperature is between 40°F and 100°F.
- ii. **Filling:** Pour the sealant directly into the cracks until slightly overfilled.
- iii. **Tooling:** Use a squeegee to smooth the sealant and ensure it fills the crack evenly.

**e. Curing:**

- i. Allow 24 to 48 hours for the sealant to cure before opening the area to traffic, as per the manufacturer's recommendations.

**2. Caltrans Type I Slurry Sealing**

**a. Materials**

- i. **Aggregate:** Type I slurry aggregate per Caltrans Standard Specifications Section 37-2.2, with a maximum particle size of 4.75 mm (No. 4 sieve) for smooth-textured surfaces.
- ii. **Emulsion:** Polymer-modified asphalt emulsion meeting Caltrans Section 37-2.2 standards
- iii. **Water:** Potable water free of harmful salts and contaminants.
- iv. **Additives:** Mineral fillers like Portland cement, hydrated lime, or aluminum sulfate as required.

**b. Equipment:**

- i. Slurry seal mixing machine with continuous flow mixing and agitating capabilities.
- ii. Spreader box with augers and a drag box for even distribution.

**c. Preparation:**

- i. **Surface Cleaning:** Remove all loose material, dust, and debris using mechanical sweepers and high-pressure air.
- ii. **Crack Sealing:** Perform crack sealing as specified above, ensuring all cracks are sealed before slurry application.
- iii. **Surface Priming:** If required, apply a tack coat to improve adhesion.

**d. Application:**

- i. **Mixing:** Blend aggregate, emulsion, water, and additives to achieve a homogeneous mix.
- ii. **Spreading:** Apply the slurry mix uniformly over the pavement using the spreader box. Maintain consistent thickness and ensure no ridges or uneven surfaces.
- iii. **Edge Control:** Use edge protectors to ensure clean and straight edges along curbs and gutters.

**e. Curing:**

- i. Allow the slurry seal to cure for 24 to 48 hours, depending on weather conditions and manufacturer's recommendations, before allowing traffic.

**3. Striping and Curb Painting**

**a. Materials**

- i. **Paint:** Traffic-grade, waterborne traffic paint, Caltrans-approved, VOC-compliant..
- ii. **Glass Beads:** For reflective striping, use glass beads meeting AASHTO M247 standards.

- b. Equipment:**
  - i. Airless or air-atomized striping machine.
  - ii. Stencils for specific markings (e.g., handicap symbols, arrows).
  - iii. Wire brushes or mechanical grinders for surface preparation.
- c. Preparation:**
  - i. **Surface Cleaning:** Ensure the surface is clean, dry, and free of loose material, oil, and debris.
  - ii. **Layout:** Mark the layout using chalk lines or temporary paint.
- d. Application:**
  - i. **Temperature:** Apply paint when the pavement temperature is above 50°F and below 95°F.
  - ii. **Striping:** Apply paint using a striping machine at the specified thickness and width. For reflective striping, apply glass beads immediately after the paint.
  - iii. **Curb Painting:** Apply paint using a striping machine or brushes or rollers to apply paint to curbs, ensuring even coverage and avoiding drips or overspray.
- e. Curing:**
  - i. Allow the paint to dry and cure per the manufacturer's recommendations before allowing traffic.

### General Notes

- **Weather Conditions:** Do not apply materials during rain or when rain is imminent within 24 hours of application.
- **Traffic Control:** Implement appropriate traffic control measures to protect workers and ensure the safety of the public.
- **Quality Control:** Regularly check the work to ensure compliance with specifications, including material quality, application thickness, and curing times.

APPENDIX A

**CONSTRUCTION DRAWINGS  
(Site Maps)**

**See Attachments**









**PLEASANT VALLEY RECREATION AND PARK DISTRICT  
STAFF REPORT / AGENDA REPORT**

**TO: BOARD OF DIRECTORS**

**FROM: MARY OTTEN, GENERAL MANAGER**  
**By: Nick Marienthal, Park Supervisor**

**DATE: March 5, 2025**

**SUBJECT: CONSIDERATION AND APPROVAL OF BID AWARD  
FOR SPRINGVILLE PARK WROUGHT IRON FENCE  
REPAIR AND APPROVE A CLOSURE OF  
SPRINGVILLE DOG PARK FOR TURF MAINTENANCE**

**BACKGROUND**

Springville Park was developed in 1997 as a five-acre park. In 2013, the District converted a portion of the upper park and softball field into an enclosed dog park, while the lower section of the park remains designated for tennis and pickleball courts.

During the development of the Fiscal Year Budget 2024/2025, staff identified large sections of the wrought iron fencing on both the upper and lower sections of the park that were in disrepair. To address these concerns, \$80,000 was allocated for the project. The planned fence replacement includes approximately 250 linear feet of fencing along the lower portion of the park, specifically on the north side, and 14 panels on the upper fence, which is located on the south side of the large dog area, along Via Zamora Street. These replacements will enhance safety, security, and the overall appearance of the park while ensuring the integrity of the enclosed spaces.

**ANALYSIS**

The project scope includes the replacement of approximately 14 rotten panels and five curved panels on the upper section surrounding the dog park, as well as 250 linear feet of fencing on the lower section along Via Zamora Street. To enhance durability and longevity, staff specified a thicker gauge material in the bid requirements.

The project was publicly advertised through the **California Uniform Construction Cost Accounting Commission** (CUPCCAA) approved trade journals. A mandatory job walk on January 7, 2025, with four contractors in attendance, allowing interested parties to inspect the project site and ask questions. Bids were due on January 23, 2025, and the District received two bids. However, one bid was disqualified for failing to meet the required bid specifications, leaving GNR Fencing as the sole qualified bidder.

Given that this project is under the \$200,00 threshold, the District followed the CUPCCAA process, which included public advertisement, a mandatory job walk, competitive bidding, and bid qualification to ensure compliance and fairness in the contractor selection.

GNR Fencing submitted a bid of \$85,500, which exceeds the project’s allocated budget of \$80,000 by \$5,500. Staff has identified cost savings from the playground replacements at Quito Park and Calleguas Creek Park, allowing the overage to be absorbed within the overall FY 24/25 Capital budget without impacting other planned projects. Given the critical need for these fence replacements to maintain safety and security, and considering the competitive bidding process, staff recommends awarding the contract to GNR Fencing.

COMPANY	BID AMOUNT
GNR Fencing	\$85,500

**CLOSURE**

During the repair of the fencing, staff is asking for a closure of the dog park to simultaneously address turf maintenance. Staff anticipates that a significant portion of the large dog park will need to be closed for a minimum of 2.5 weeks as part of the installation of the replacement fence. This temporary closure will allow for a comprehensive approach to maintenance, ensuring the turf has the opportunity to recover and rejuvenate without the pressure of heavy use on a smaller area of the park.

Springville Dog Park is heavily used throughout the year giving staff minimal time for turf maintenance and rest. The timing of this closure is beneficial, as it coincides with periods of lower park attendance, allowing for the necessary repairs and maintenance to occur without significantly impacting the user experience. In addition, the District built a lighted dog park at Freedom Park in 2023, thus providing the citizens with alternative locations for their dogs, along with Mission Oaks and Camarillo Grove Park Dog Parks. This ensures that dog owners still have access to quality facilities during Springville Dog Park’s temporary closure, promoting the well-being of the park and its patrons.

**TIMELINE**

- Fence repair and Dog Park closure for turf maintenance start March 24, 2024
- Dog Park would be scheduled to re-open April 28, 2025

**FISCAL IMPACT**

The District allocated \$80,000 in the FY 24/25 Capital Budget for the wrought iron fence repair at Springville Park. However, the bid received for this project was \$85,500. To address this \$5,500 overage, staff identified cost savings from the playground replacements at Quito Park and Calleguas Creek Park. These savings will allow the excess costs to be absorbed within the overall FY 24/25 Capital Budget without impacting other planned projects.

**STRATEGIC PLAN COMPLIANCE**

Meets 2021-2026 Strategic Plan Goal and Strategy

- 3.1: Renovate and modernize existing parks and recreation facilities to ensure all parks provide an adequate range and supply of active leisure facilities to meet the growth and diversity in population, programming trends, and new design standards.

## **RECOMMENDATION**

It is recommended that the Board:

1. Authorize the General Manager to enter into an agreement with GNR Fencing for an amount not to exceed \$85,500 for the wrought iron fence repair at Springville Park.
2. Authorize the closure of Springville Dog Park from March 24<sup>th</sup> to April 28<sup>th</sup> for fencing repairs and turf maintenance.

## **ATTACHMENTS**

- 1) GNR Fencing Bid Packet (18 pages)
- 2) Professional Services Agreement (46 pages)



**BID FORM**

FIRM NAME: GNR Fence, INC

POINT OF CONTACT: Guillermo Navarrete

ADDRESS: 2054 Snow Ave

Oxnard CA 93036

TELEPHONE NUMBER: 805 797 0367

FAX NUMBER: \_\_\_\_\_

FOR THE

**SPRINGVILLE PARK FENCING REPAIR AND  
REPLACEMENT PROJECT**

SPEC NO. SVPF-24-25

FISCAL YEAR 2024-2025

PLEASANT VALLEY RECREATION & PARK DISTRICT

PLEASANT VALLEY RECREATION & PARK DISTRICT

SPRINGVILLE PARK FENCING REPAIR AND REPLACEMENT PROJECT  
SPEC NO. SVPF-24-25

BID SCHEDULE

ITEM NO.	DESCRIPTION	ESTIMATED QUANTITY	UNIT	UNIT COST	TOTAL ITEM AMOUNT	NOTE
1.	Dog Park wrought Iron Fencing Repair	250' +/-	\$ 90.00 LF	\$ 22,500.00	\$ 22,500.00	Includes Temp Fence
2.						
3.	Wrought Iron Fencing on the Tennis court side via Zamora	250'	\$ 252.00 LF	\$ 63,000.00	\$ 63,000.00	Including temp Fence
4.	Per Bid Specifications.					
5.						
6.						
7.						
8.						
9.						
10.						
11.						
12.						
13.						
14.						
15.						

ITEM NO.	DESCRIPTION	ESTIMATED QUANTITY	UNIT	UNIT COST	TOTAL ITEM AMOUNT	NOTE
16.						
17.						
18.						
19.						
20.						
21.						
22.						
23.						
24.						
TOTAL BID AMOUNT IN FIGURES					\$ 85,500.00	
TOTAL BID AMOUNT IN WORDS					Eighty five thousand five hundred dls 00/100-	

Guillermo Navarrete  
Bidder Name

  
Signature of Bidder

Dated 1-23-2025



## RESOLUTION OF CONSTRUCTION CLAIMS

(To Be Executed By Bidder and Submitted With Bid)

When a Public Works claim is made to the District, the District will conduct a reasonable review of the claim and, within 45 days, provide the claimant with a written statement identifying what portion of the claim is disputed and what portion is undisputed and both parties shall work to resolve the claim as by Public Contract Code 9204. (A copy of Section 9204 may be found in the Special Provisions, under "Resolution of Construction Claims").

Additionally, in all Public Works claims, which may arise between the Contractor and the District which do not exceed the sum of three hundred seventy-five thousand dollars (\$375,000), the requirements of California Public Contract Code, Section 20104 through 20104.6, inclusive, shall apply. (A copy of said Code Sections may be found in the Special Provisions, under "Resolution of Construction Claims of \$375,000 or Less".) Said Code Sections shall apply for the purpose of filing claims and civil actions for claims as defined in Section 20104 of the Public Contract Code.

The bidder's signature is required to verify he/she has reviewed the Code Sections.

Guillermo Navarrese

Bidder Name

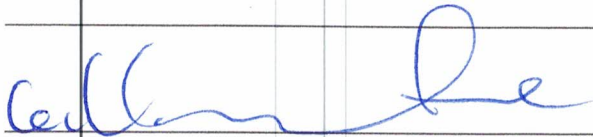

Signature of Bidder

Dated 1-23-2025

**BID BOND**  
(10% of the Bid Amount)

**KNOW ALL MEN BY THESE PRESENTS** that we GNR Fence, Inc.  
as Principal, hereinafter referred to as "Contractor" and Granite Re, Inc. dba Granite Surety Insurance Company  
as Surety, are held and firmly bound unto the Pleasant Valley Recreation & Park District,  
hereinafter called the "District," in the sum of  
Ten Percent of Bid Amount Dollars (\$ 10% ), for the  
payment of which sum well and truly to be made, we bind ourselves, our heirs, executors,  
administrators, and successors, jointly and severally, firmly by these presents. The conditions of  
this obligation are such that whereas the Contractor submitted to the District a certain Bid, attached  
hereto and hereby made a part hereof, to enter into a contract in writing for the \_\_\_\_\_  
Springville Park Fencing Repair and Replacement Project, Spec No. SVPF-24-25

and will furnish all required certificates of insurance and bonds as required by the Contract.

**NOW, THEREFORE**, if said Bid shall be rejected; or in the alternate, if said Bid is accepted, and  
the Contractor (i) executes and delivers a contract in the prescribed form of the Agreement, (ii)  
delivers certificates evidencing that the required insurance is in effect, (iii) executes and delivers  
Performance and Payment Bonds in the forms prescribed, and (iv) in all other respects performs  
the agreement created by the acceptance of said Bid, then this obligation shall be void; otherwise  
this obligation shall remain in full force and effect, it being expressly understood and agreed that  
the liability of the Surety for any and all default of the Contractor hereunder shall be the amount  
of this obligation as herein stated. In the event suit is brought upon this bond by District and  
judgment is recovered, Surety shall pay all costs incurred by District in said suit, including a  
reasonable attorney's fee to be fixed by the court.

The Surety, for the value received, hereby stipulates and agrees that the obligations of said Surety  
and its bond shall in no way be impaired or affected by an extension of the time within which the  
District may accept such a bid; and said Surety does hereby waive notice of any such extension.

IN WITNESS WHEREOF, the above-bound parties have executed this instrument under their  
several seals this 23rd day of January, 2025, the name and corporate seal of  
each corporate party being hereto affixed and these presents duly signed by its undersigned  
representative, pursuant to authority of its governing body.

ATTEST:

GNR Fence, Inc.

(Contractor)

2054 Snow Ave

(Address)

Oxnard, CA 93036

D-1

Bill [Signature]

(By)

CEO

(Title)

ATTEST:

Granite Re, Inc. dba Granite Surety Insurance Company

(Surety)

14001 Quailbrook Drive

(Address)

Oklahoma City, OK 73134

[Signature]

(By)

Kenneth D. Whittington, Attorney-In-Fact

(Title)



(To be filled in by Surety):

The rate of premium on this bond is \$ 25 per thousand.

The total amount of premium charged is \$ N/A - Premium not charged until Performance/Payment Bonds Issued

**NOTARY PUBLIC ATTACH CALIFORNIA ALL-PURPOSE ACKNOWLEDGEMENT**



**CALIFORNIA ALL-PURPOSE ACKNOWLEDGMENT**

A notary public or other officer completing this certificate verifies only the identity of the individual who signed the document to which this certificate is attached, and not the truthfulness, accuracy, or validity of that document.

State of California)  
County of Ventura)

On 1/22/2025 before me, ABEL BARRAGAN, Notary Public, personally appeared, Guillermo Navarrete Rocha, who proved to me on the basis of satisfactory evidence to be the person whose name is subscribed to the within instrument and acknowledged to me that he executed the same in his authorized capacity, and that by his signature on the instrument the person, or the entity upon behalf of which the person acted, executed the instrument.

I certify under PENALTY OF PERJURY under the laws of the State of California that the foregoing paragraph is true and correct.

WITNESS my hand and official seal.

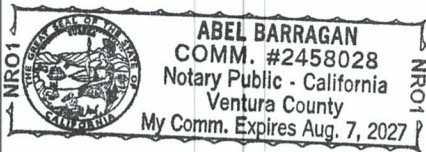

Signature \_\_\_\_\_

A handwritten signature in black ink, appearing to read 'Abel Barragan', written over a horizontal line.

*Signature of Notary Public*

**ACKNOWLEDGMENT OF SURETY**

State of Oklahoma  
County of Oklahoma

On this 23 day of January, 2025 before me personally come(s) Kenneth D. Whittington, Attorney in-Fact of Granite Re, Inc. dba Granite Surety Insurance Company with whom I am personally acquainted, and who, being by me duly sworn, says that he reside(s) in Oklahoma City, Oklahoma that he is the Attorney in Fact of Granite Re, Inc. dba Granite Surety Insurance Company, the company described in and which executed the within instrument; that he know(s) the corporate seal of such Company; and that the seal affixed to the within instrument is such corporate seal and that it was affixed by order of the Board of Directors of said company, and he signed said instrument as Attorney(s)-in-Fact of the said Company by like order.

*Bethany J. Alred*

Notary Public









## INFORMATION REQUIRED OF BIDDERS

**The bidder is required to supply the following information.**

(Additional sheets may be attached if necessary.)

- (1) Address: 2054 Snow Ave Oxnard CA 93036
- (2) Telephone: (805) 797 0367
- (3) Type of Firm: Corporation  
(Individual, Partnership, or Corporation)
- (4) Contractor's State License Classification C-13 Expiration date 11-30-2025
- (5) Corporate organized under the laws of the State of: California
- (6) Is 51% or more of the business owned by: American Indian ( ), Asian ( ), Black ( ), Hispanic ( ), Female ( ), Other (Specify) Hispanic.
- (7) List the names and addresses of all members of the firm, or names and titles of all officers of the corporation.

Guillermo Navarrete

- (8) Number of years of experience as a Contractor in construction work. 17
- (9) List at least three (3) completed \_\_\_\_\_ projects completed in the last 12 months:

Contract Amount	Class of Work	Date Completed	Name, Contact, Address and Telephone No. of Client
\$ <u>87,000</u>	<u>Guard Rail</u>	<u>11-15-24</u>	<u>V. Lopez Jr &amp; Sons 1639 E. Donovan Rd Santa Maria, ca (805) 928 1198</u>
\$ <u>47,000</u>	<u>wood split Bed</u>	<u>12-2-2024</u>	<u>FS Contractors 14838 Bledsoe St Simlar, Ca (805) 838 6040</u>
\$ <u>56,000</u>	<u>Wraithon Fence</u>	<u>10-23-24</u>	<u>Ada General Eng Inc 1011 Elder St. Oxnard ca, (805) 807 9882</u>

(10) List the name of the person who inspected the site of the proposed work for your firm:

Guillermo Navarrete

Date of Inspection: \_\_\_\_\_

(11) If requested by the District, the Bidder shall furnish a notarized financial statement, financial data, or other information and reference sufficiently comprehensive to permit an appraisal of Bidder's current financial condition.

(12) List the name and address of all **subcontractors who will perform work** in or about the project and indicate what part of the work will be done by each such Subcontractor.

NAME: \_\_\_\_\_

ADDRESS: \_\_\_\_\_

LICENSE NO. & CLASS: \_\_\_\_\_

WORK TO BE PERFORMED: \_\_\_\_\_

NAME: \_\_\_\_\_

ADDRESS: \_\_\_\_\_

LICENSE NO. & CLASS: \_\_\_\_\_

WORK TO BE PERFORMED: \_\_\_\_\_

NAME: \_\_\_\_\_

ADDRESS: \_\_\_\_\_

LICENSE NO. & CLASS: \_\_\_\_\_

WORK TO BE PERFORMED: \_\_\_\_\_

NAME: \_\_\_\_\_

ADDRESS: \_\_\_\_\_

LICENSE NO. & CLASS: \_\_\_\_\_

WORK TO BE PERFORMED: \_\_\_\_\_

NAME: \_\_\_\_\_

ADDRESS: \_\_\_\_\_

LICENSE NO. & CLASS: \_\_\_\_\_

WORK TO BE PERFORMED: \_\_\_\_\_



List the name and address of **Major Equipment Suppliers** who will provide equipment or major components for the project.

NAME: \_\_\_\_\_

ADDRESS: \_\_\_\_\_

EQUIPMENT TO BE PROVIDED: \_\_\_\_\_

NAME: \_\_\_\_\_

ADDRESS: \_\_\_\_\_

EQUIPMENT TO BE PROVIDED: \_\_\_\_\_

NAME: \_\_\_\_\_

ADDRESS: \_\_\_\_\_

EQUIPMENT TO BE PROVIDED: \_\_\_\_\_

NAME: \_\_\_\_\_

ADDRESS: \_\_\_\_\_

EQUIPMENT TO BE PROVIDED: \_\_\_\_\_

NAME: \_\_\_\_\_

ADDRESS: \_\_\_\_\_

EQUIPMENT TO BE PROVIDED: \_\_\_\_\_

(13) The Contractor shall furnish the following information concerning bid depository or registry services used in obtaining subcontractor bid figures for this Bid. Additional sheets may be attached if necessary.

A. Were bid depository or registry services used in obtaining subcontractor bid figures in order to compute your bid? Yes ( ) No (X)

B. If the answer to "A." is "Yes," forward a copy of the rules of each bid depository you used in the preparation of this Bid.

C. Did you have any source of subcontractor bids other than bid depositories? Yes ( ) No (X)

D. Has any person or group threatened you with subcontractor boycotts, union boycotts, or other sanctions to attempt to convince you to use the services or abide by the rules of one or more bid depositories? Yes ( ) No (X)

E. If the answer to "D" is "Yes", please explain the following details:

(a) Date: \_\_\_\_\_

(b) Name of person or group: \_\_\_\_\_

(c) Job involved (if applicable): \_\_\_\_\_

(d) Nature of threats: \_\_\_\_\_

\_\_\_\_\_  
\_\_\_\_\_  
\_\_\_\_\_

(e) Additional comments: \_\_\_\_\_

\_\_\_\_\_  
\_\_\_\_\_  
\_\_\_\_\_

**(TO ACCOMPANY BID)**

In accordance with Public Contracting Code Section 10162, the bidder shall complete, under penalty of perjury, the following questionnaire:

**QUESTIONNAIRE**

Has the bidder, any officer of the bidder, or any employee of the bidder who has a proprietary interest in the bidder, ever been disqualified, removed, or otherwise prevented from bidding on or completing a Federal, State, or local government project because of a violation of law or a safety regulation?

Yes \_\_\_\_\_ No X

If the answer is yes, explain the circumstances in the following space:

Note: This questionnaire constitutes a part of the Bid, and a signature on the Bid shall be constituted a signature on this questionnaire.

**CONTRACTOR LICENSE AFFIDAVIT**

STATE OF CALIFORNIA )  
COUNTY OF CA ) ss.

Guillermo Navarrete, being first duly sworn, deposes  
Name

and says that he or she is C.E.O of GNR Fence INC,  
Title Name of Firm

the party making the foregoing bid, is a licensed Contractor, a duly authorized partner of a Joint Venture which holds a license as a Partnership, or a duly authorized principal and/or representative of a Corporation which holds a license as a Corporation, and that he or she understands the information shown below shall be included with the bid, and understands that any bid not containing this information, or if this information is subsequently proven to be false, shall be considered non-responsive and shall be rejected by the Pleasant Valley Recreation & Park District.

1032835 C-13  
Contractor's State License Number and Classification  
11-30-25  
License Expiration Date

I certify under penalty of perjury under the laws of the State of California that the foregoing is true and correct.

Subscribed at: Oxnard CA  
(City and County, State)

on January 23, 2025.

Guillermo Navarrete 1032835 C-13  
Signature State License Number and Classification

2054 Snow Ave Oxnard CA 93036  
Street Address City State Zip Code

Telephone Number (965) 797 0367

# CALIFORNIA ALL-PURPOSE ACKNOWLEDGEMENT

A notary public or other officer completing this certificate verifies only the identity of the individual who signed the document to which this certificate is attached, and not the truthfulness, accuracy, or validity of that document.

State of California)  
County of Ventura)

On 1/23/2025 before me, Lilia Barragan, Notary Public, personally appeared, Guillermo Navarrete, who proved to me on the basis of satisfactory evidence to be the person whose name is subscribed to the within instrument and acknowledged to me that she executed the same in her authorized capacity, and that by her signature on the instrument the person, or the entity upon behalf of which the person acted, executed the instrument.

I certify under PENALTY OF PERJURY under the laws of the State of California that the foregoing paragraph is true and correct.

WITNESS my hand and official seal.



Signature *Lilia Barragan*  
*Signature of Notary Public*



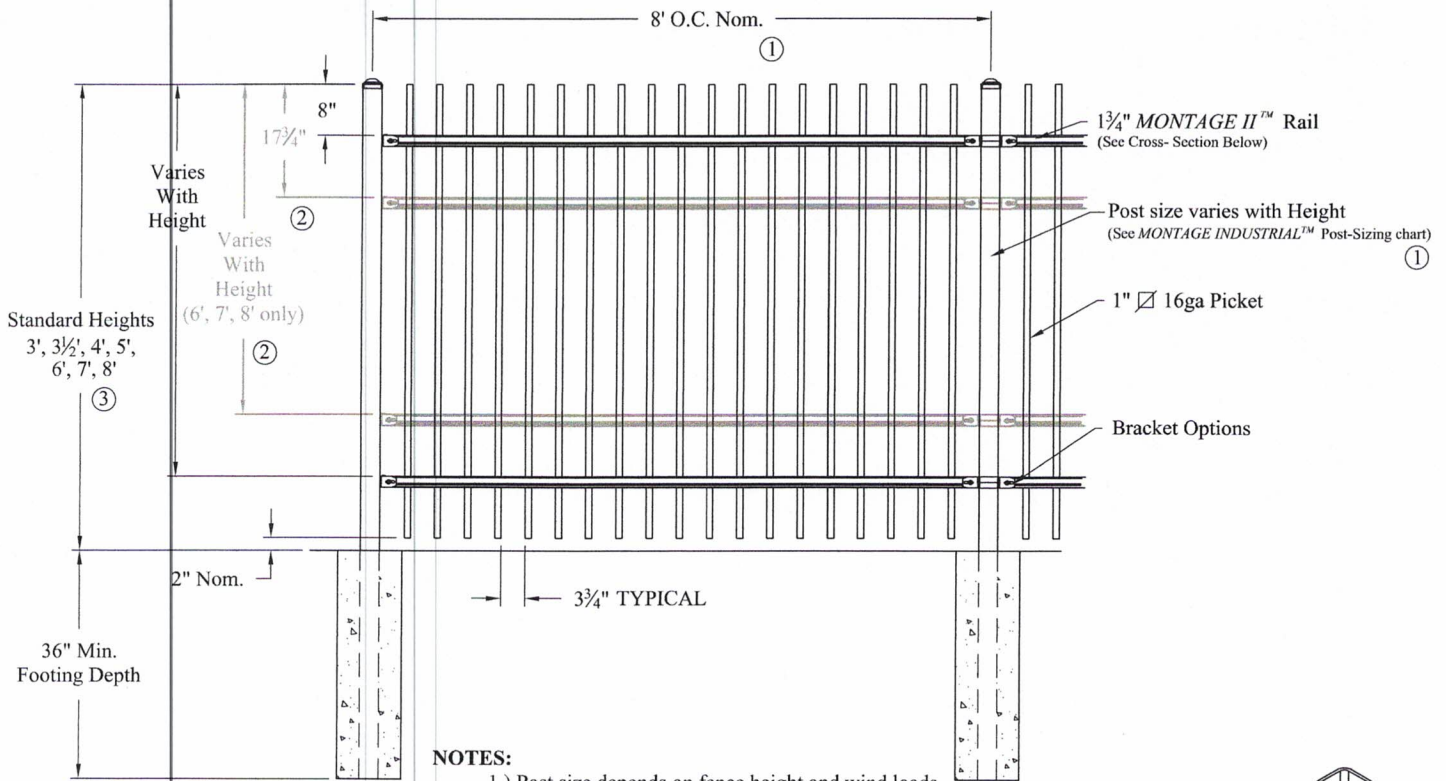

**NOTES:**

- 1.) Post size depends on fence height and wind loads. See MONTAGE INDUSTRIAL™ specifications for post sizing chart and setting dimensions.
- 2.) Third & Fourth rail optional.
- 3.) Available in Flush Bottom.

**RAKING DIRECTIONAL ARROW**  
Welded panel can be raked 30" over 8' with arrow pointing down grade.

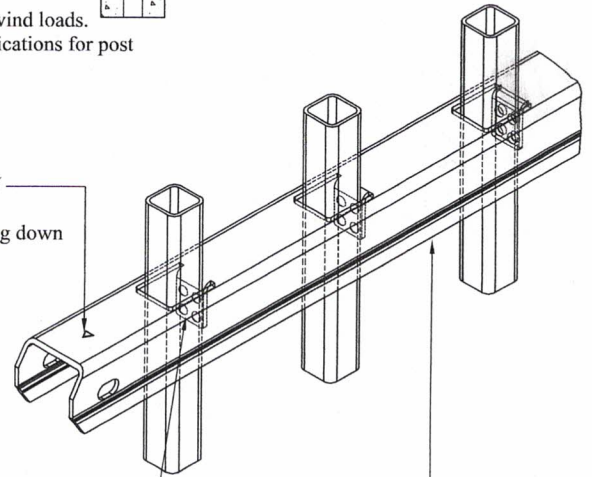

**PROFUSION™ WELDING PROCESS**  
No exposed welds, Good Neighbor profile - Same appearance on both sides

**MONTAGE II™ RAIL**  
Specially formed high strength architectural shape.

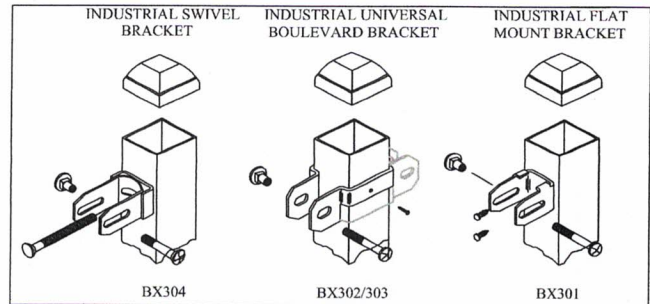
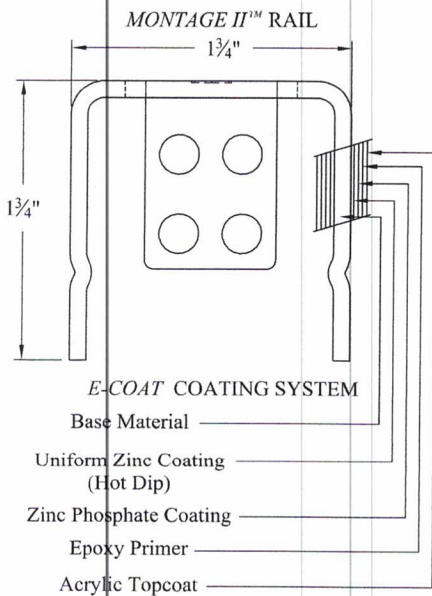

**HEAVY INDUSTRIAL STRENGTH WELDED STEEL PANEL**  
**PRE-ASSEMBLED**

Values shown are nominal and not to be used for installation purposes. See product specification for installation requirements.

2RGISO

Title: **MONTAGE INDUSTRIAL GENESIS 2/3/4-RAIL**

DR: CI SH. 1 of 1 SCALE: DO NOT SCALE

CK: ME Date 6/28/10 REV: b



**AMERISTAR™**

1555 N. Mingo  
Tulsa, OK 74116  
1-888-333-3422  
www.ameristarfence.com

240/288





## AGREEMENT

**THIS AGREEMENT**, made and entered into by and between the **PLEASANT VALLEY RECREATION & PARK DISTRICT, CALIFORNIA**, hereinafter referred to as the "**District**" and **GNR Fencing** hereinafter referred to as the "**Contractor**".

**WITNESSETH:** That the parties hereto do mutually agree as follows:

**ARTICLE I:** For and in consideration of the payments and agreements hereinafter mentioned to be made and performed by said District, said Contractor agrees with said District to construct the work under the District's specification entitled "SPRINGVILLE PARK FENCING REPAIR AND REPLACEMENT PROJECT, SPEC NO. PPG-24-25" and to perform and complete in a good and workmanlike manner all the work pertaining thereto shown on the drawings and described in the specifications herein, to furnish at his or her own proper cost and expense all tools, equipment, labor, and materials necessary therefor, except such material and equipment as in said specifications as expressly stipulated to be furnished by said District, and to do everything required by this Agreement and the said specifications and drawings.

**ARTICLE II:** For furnishing all said materials and labor, furnishing and removing all plant, temporary works or structures, tools and equipment and doing all the work contemplated and embraced in this Agreement, also for all loss and damage arising out of the nature of the work aforesaid, or from the action of the elements, or from any unforeseen difficulties which may arise from or be encountered in the prosecution of the work until its acceptance by said District, and for all risks of every description connected with the work; also for all expenses incurred by or in consequence of the suspension or discontinuance of work, except such as in the said specifications are expressly stipulated to be borne by said District, and for well and faithfully completing the work the whole thereof, in the manner shown and described in said drawings and specifications and in accordance with the requirements of the Engineer, said District will pay and said Contractor shall receive in full compensation therefor the prices named in the Bidding Schedule of the Bid hereto attached.

**ARTICLE III:** All work to be done under this contract shall be completed within **Thirty-five (35) consecutive working days**, exclusive of maintenance periods, beginning on the date stipulated in the written Notice to Proceed issued by the Engineer. Any changes in time and/or price are to be submitted to the District Engineer, in writing, within 3 days of the occurrence giving rise to the request and shall request a formal decision from the District within 3 days and shall include data supporting the request.

**ARTICLE IV:** The District hereby promises and agrees with said Contractor to employ, and does hereby employ, said Contractor to provide the materials and to do the work according to the terms and conditions herein contained and referred to for the price aforesaid, and hereby contracts to pay for the same, at the time, in the manner, and upon the conditions set forth in said specifications; and the said parties for themselves, their heirs, executors, administrators, successors, and assigns, do hereby agree to the full performance of the covenants herein contained.



**ARTICLE V:** The Notice Inviting Sealed Bids, the Instructions to Bidders, the Bid, the Specifications, and the Drawings mentioned therein, all addenda issued prior to the opening of the bid by the District, all contract change orders issued after execution of the Contract Agreement, the Special Provisions, Non-Collusion Declaration, Faithful Performance Bond, Payment Bond, all of which are essential parts of this contract, are hereby incorporated in and made part of this Agreement.

**ARTICLE VI:** Contractor acknowledges the provisions of Labor Code Section 1860 requiring every employer to be insured against liability for worker's compensation, or to undertake self-insurance in accordance with the provisions of that code, and certifies that it is in compliance with such provisions.

**ARTICLE VII:** The Contractor shall supply the District with Certificates evidencing all required insurance policies as described in the Instructions to Bidders.

**ARTICLE VIII:** The Contractor certifies that he or she is aware of the provisions of Public Contract Code Section 6109 and that any contractor or subcontractor who is ineligible under Labor Code Sections 17771.1 and 1777.7 is prohibited from working on this Project.

**ARTICLE IX:** Contractor acknowledges and agrees to comply with the provisions of the State Labor Code requiring every employer to pay at least the minimum prevailing rate of per diem wages for each craft, classification, or type of workman needed to execute this contract. State general prevailing wage determination as established by the California Department of Industrial Relations (available at <http://www.dir.ca.gov/DLSR/PWD/index.htm>) and the contractor shall post all required job site notices. The statutory provisions for penalties for failure to pay prevailing wages and/or failure to otherwise comply with state's wage and hour laws will be enforced. This contract is subject to compliance monitoring and enforcement by the Department of Industrial Relations. Contractor agrees that eight hours' labor constitutes a legal day's work.

The Contractor hereby agrees that the Contractor, and any subcontractor under the Contractor, shall pay not less than the general prevailing rate of per diem wages, as determined by the Director of the Department of Industrial Relations, to all workers employed in the execution of this contract as required under Subsection 5-3.2 of the 2021 Standard Specifications for Public Works Construction, and shall submit weekly to the District, certified copies of the payroll records for all said workers and shall comply with all statutory requirements relating to certified copies of payroll records, including the maintenance of the records, their certification, and their availability for inspection as required by Labor Code Section 1776 and as required under Subsection 5-3.3 of said Standard Specifications for Public Works Construction. In addition, the Contractor and any subcontractors must furnish electronic certified payroll records directly to the Labor Commissioner (aka Division of Labor Standards Enforcement) in a format prescribed by the Labor Commissioner no less than monthly. The Labor Commissioner may at any time require the contractors and subcontractors to furnish electronic certified payroll records.

The prevailing rate of per diem wages are on file at the Pleasant Valley Recreation & Park District, Department of Public Works, 1605 E. Burnley Street, Camarillo, CA 93010, and are available to any interested party on request. The Contractor is required to post at the job site the prevailing rate

of per diem wages as determined by the Director of the Department of Industrial Relations and other notices prescribed by regulation.

Contractor and any subcontractor under the Contractor must comply with the requirements of California Labor Code Sections 1777.5 and 1777.6 regarding the employment of apprentices.

**ARTICLE X:** The Contractor hereby agrees to indemnify and defend the District, its officers, agents, and employees against, and to hold and save them and each of them harmless from, any and all actions, suits, claims, damages to persons or property, losses, costs, penalties, obligations, errors, omissions, or liabilities (hereinafter "Claims or Liabilities") that may be asserted or claimed by any person, firm, or entity arising out of or in connection with this Agreement, the construction of the project, any alleged breach or breach of any provision set forth in this Agreement or the plans or specifications for the project, design defects, any alleged violation or violation of any federal, state, or local, law, ordinance, statute, rule, regulation, or order, any failure or alleged failure to secure any applicable regulatory permit, license, or agreement, and the errors and omissions, willful misconduct, or negligence, whether said negligence is concurrent, active or passive, of the Contractor, its officers, agents, employees, or any other persons, except that the Contractor shall not be required to indemnify, defend, and hold harmless the District, its officers, agents, and employees against Claims or Liabilities caused by the negligence or willful misconduct or active negligence of the District, its officers, agents, or employees.

**ARTICLE XI:** The District, in accordance with Public Contract Code Section 22300, shall permit the substitution of securities for any moneys withheld by the District to secure performance under a contract. The District hereby incorporates herein all of the provisions set forth in Public Contract Code Section 22300.

**ARTICLE XII:** In the performance of this agreement, the Contractor shall not engage in, nor permit others he or she may hire to engage in, discrimination in the employment of persons because of their race, religious creed, color, or national origin, except as provided in Government Code Section 12940. Violation of this provision may result in the imposition of penalties as provided in Labor Code Section 1735.

**ARTICLE XIII:** Contractor will be compensated for any utility relocation required as part of the project which is not shown on the plans and Contractor will not be assessed liquidated damages for any delays caused by the District's or a public utility's failure to provide for removal or relocation of utility facilities.

**ARTICLE XIV:** The Contractor shall maintain accounts and records, including personnel, property, and financial records, adequate to identify and account for all costs pertaining to the contract and such other records as may be deemed necessary by the District to assure proper accounting for all project funds, both federal and non-federal shares. These records will be made available for audit purposes to the District or any authorized representative and will be retained for 3 years after the expiration of this contract, unless permission to destroy them is granted by the District.

**ARTICLE XV:** No officer or employee of the District shall have any financial interest in this Agreement nor shall any such officer or employee participate in any decision relating to the

Agreement which affects his or her financial interest or the financial interest of any corporation, partnership or association in which he or she is interested, in violation of any State statute or regulation. Similarly, Contractor warrants that it has not paid or given and will not pay or give any third party any money or other consideration for obtaining this Agreement.

**ARTICLE XVI:** The persons executing this Agreement on behalf of the parties hereto warrant that (i) such party is duly organized and existing, (ii) they are duly authorized to execute and deliver this Agreement on behalf of said party, (iii) by so executing this Agreement, such party is formally bound to the provisions of this Agreement, and (iv) the entering into this Agreement does not violate any provision of any other Agreement to which said party is bound.

**ARTICLE XVII:** Legal actions concerning any dispute, claim or matter arising out of or in relation to this Agreement shall be instituted in the Superior Court of the County of Ventura, State of California, or any other appropriate court in such county, and Contractor agrees to submit to the personal jurisdiction of such court in the event of such action.

**ARTICLE XVIII:** District will timely notify Contractor of any third party claim received by the District relating to this Agreement.

[Signatures on next page]

**DISTRICT: PLEASANT VALLEY  
RECREATION & PARK DISTRICT,  
CALIFORNIA**

Dated, March 5, 2025

By: \_\_\_\_\_  
\_\_\_\_\_, Chairman

ATTEST:

\_\_\_\_\_  
\_\_\_\_\_, Clerk of the Board

Dated, February 11, 2025

**CONTRACTOR: GNR Fencing Inc.**

By:   
\_\_\_\_\_  
AUTHORIZED REPRESENTATIVE

CEO

TITLE

By:   
\_\_\_\_\_  
AUTHORIZED REPRESENTATIVE

TREASURER

TITLE

(Attach acknowledgment for each  
Authorized Representative of Contractor.)

Address: 2054 Snow Avenue  
Oxnard, Ca 93036  
Phone: (805) 797-0367  
Fax: N/A  
Email: Gnrfencing@outlook.com



**LABOR AND MATERIAL BOND  
(PAYMENT BOND)**

WHEREAS, the PLEASANT VALLEY RECREATION & PARK DISTRICT, (“District”), has awarded to GNR Fencing, as Contractor (“Contractor”), a Contract for the work entitled and described as follows:

**SPRINGVILLE PARK FENCING REPAIR AND  
REPLACEMENT PROJECT**

**SPEC NO. SVPF-24-25**

WHEREAS, said Contractor is required to furnish a bond in conjunction with said Contract, to secure the payment of claims of laborers, mechanics, material men, and other persons as provided by law;

NOW, THEREFORE, we the undersigned Contractor and Surety, are held and firmly bound unto the District in the sum of Eighty- Five Thousand Five Hundred Dollars (\$85,500), this amount being not less than one hundred percent (100%) of the total contract price, lawful money of the United States of America, for payment of which sum well and truly be made we bind ourselves, our heirs, executors, administrators, and successors, jointly and severally, firmly by these presents. In case suit is brought upon this bond, the Surety will pay a reasonable attorney’s fee to the District in an amount to be fixed by the court.

THE CONDITION OF THIS OBLIGATION IS SUCH THAT, if said Contractor, its heirs, executors, administrators, successors, assigns, or subcontractor fails to pay: (1) for any work, materials, services, provisions, provender, or other supplies, or for the use of implements of machinery, used in, upon, for, or about the performance of the work to be done, or for any work or labor thereon of any kind; (2) for work performed by any of the persons named in Civil Code Section 9100; (3) for any amounts due under the Unemployment Insurance Code with respect to work or labor performed under the contract; and/or (4) for any amounts required to be deducted, withheld, and paid over to the Employment Development Department from the wages of employees of the Contractor and/or its subcontractors pursuant to Section 13020 of the Unemployment Insurance Code with respect to such work and labor, then the Surety herein will pay for the same in an amount not exceeding the sum specified in this bond, otherwise the above obligation shall be void.

This bond shall inure to the benefit of any of the persons named in Civil Code Section 9100 so as to give a right of action to such persons or their assigns in any suit brought upon the bond. Moreover, if the District or any entity or person entitled to file stop payment notices is required to engage the services of an attorney in connection with the enforcement of this bond, each shall be liable for the reasonable attorney's fees incurred, with or without suit, in addition to the above sum.

Said Surety, for value received, hereby stipulates and agrees that no change, extension of time, alteration, or modification of the Contract Documents or of the work to be performed

thereunder shall in any way affect its obligations on this bond, and it does hereby waive notice of such change, extension of time, alteration, or modification of the Contract Documents or of the work to be performed thereunder.

**IN WITNESS WHEREOF**, we have hereunto set our hands and seals this \_\_\_\_\_ day of \_\_\_\_\_, 2025.

\_\_\_\_\_ **CONTRACTOR** \_\_\_\_\_ **SURETY**

\_\_\_\_\_  
ADDRESS OF SURETY

\_\_\_\_\_  
CITY STATE ZIP

\_\_\_\_\_  
TELEPHONE

BY: \_\_\_\_\_  
(CONTRACTOR SEAL)

BY: \_\_\_\_\_  
(CONTRACTOR SEAL)

**CONTRACTOR'S CERTIFICATE  
REGARDING WORKERS' COMPENSATION**

**Labor Code Section 3700**

"Every employer except the state shall secure the payment of compensation in one or more of the following ways:

(a) By being insured against liability to pay compensation by one or more insurers duly authorized to write compensation insurance in this state.

(b) By securing from the Director of Industrial Relations a certificate of consent to self-insure either as an individual employer, or as one employer in a group of employers, which may be given upon furnishing proof satisfactory to the Director of Industrial Relations of ability to self-insure and to pay any compensation that may become due to his or her employees.

(c) For any county, city, city and county, municipal corporation, public district, public agency, or any political subdivision of the state, including each member of a pooling arrangement under a joint exercise of powers agreement (but not the state itself), by securing from the Director of Industrial Relations a certificate of consent to self-insure against workers' compensation claims, which certificate may be given upon furnishing proof satisfactory to the director of ability to administer workers' compensation claims properly, and to pay workers' compensation claims that may become due to its employees. On or before March 31, 1979, a political subdivision of the state which, on December 31, 1978, was uninsured for its liability to pay compensation, shall file a properly completed and executed application for a certificate of consent to self-insure against workers' compensation claims. The certificate shall be issued and be subject to the provisions of Section 3702.

For purposes of this section, "state" shall include the superior courts of California."

I am aware of the provisions of Section 3700 of the Labor Code, which requires every employer to be insured against liability for workers' compensation or to undertake self-insurance in accordance with the provisions of that code, and I will comply with such provisions before commencing the performance of the work of this contract.

---

**CONTRACTOR**

By: \_\_\_\_\_  
AUTHORIZED REPRESENTATIVE

---

TITLE

(In accordance with Article 5 {commencing at Section 1860}, Chapter 1, Part 7, Division 2, of the Labor Code, the above certificate must be signed and filed with the awarding body prior to performing any work under this contract.)



## **APPRENTICESHIP REQUIREMENTS**

**Labor Code, Division 2, Part 7, Chapter 1, Section 1773.3 “Notice; Required information”** states:

"(a)(1) An awarding agency shall provide notice to the Department of Industrial Relations of any public works contract subject to the requirements of this chapter, within five (5) days of the award.

(2) The notice shall be transmitted electronically in a format specified by the department and shall include the name of the contractor, any subcontractor listed on the successful bid, the bid and contract award dates, the contract amount, the estimated start and completion dates, job site location, and any additional information the department specifies that aids in the administration and enforcement of this chapter.

(b) In lieu of responding to any specific request for contract award information, the department may make the information provided by awarding bodies pursuant to this section available for public review on its Internet Web site.”

Also note **Labor Code Sections 1776(g), 1777.5 and 1777.7.**

### **NOTICE**

**THE CONTRACTOR WILL BE REQUIRED TO FURNISH THE PLEASANT VALLEY RECREATION & PARK DISTRICT WITH THE CLASSIFICATIONS OF LABORERS TO BE USED FOR THE COMPLETION OF THIS PROJECT WITHIN THREE (3) WORKING DAYS AFTER NOTIFICATION OF AWARDING OF CONTRACT.**

## PLEASANT VALLEY RECREATION & PARK DISTRICT

### GENERAL PROVISIONS

**SCOPE OF WORK:** This project will take place within the Pleasant Valley Recreation & Park District. The work to be done consists of furnishing all materials, equipment, tools, labor, and incidentals as required by the Plans, Specifications, and Contract Documents. The general items of work are provided by Plans, Specifications and Contract Documents.

**LOCATION OF WORK:**

801 Via Zamora, Camarillo, Ca. 93010

**STANDARD SPECIFICATIONS:** The Standard Specifications of the District are contained in the 2021 Edition of the Standard Specifications for Public Works Construction, with amendments and supplements, as written and promulgated by the Joint Cooperative Committee of the Southern California Chapter of the American Public Works Association and the Southern California District of the Associated General Contractors of California (“Greenbook”). Copies of these Standard Specifications are available from the publisher, Building News, Incorporated, 990 Park Center Drive, Suite E, Vista, California 92081; telephone (760) 734-1113.

The Standard Specifications set forth above will control the General Provisions, Construction Materials, and Construction Methods for this Contract, except as amended by the Plans, Special Provisions, or other Contract Documents. The following Special Provisions are supplementary and in addition to the provisions of the Standard Specifications unless otherwise noted and the section numbers of the Special Provisions coincide with those of the said Standard Specifications. Only those sections requiring elaborations, amendments, specifying of the options, or additions are called out.

**LEGAL ADDRESS OF CONTRACTOR:** The address given in the Contractor's bid on which the contract is founded is hereby designated as the place to which all notices, letters, and other communications to the Contractor shall be mailed or delivered. Unless otherwise required by law, the mailing to or delivering at the above-named place of any notice, letter, or other communication by the District to the Contractor shall be deemed sufficient service thereof upon the Contractor. The date of said service shall be the date of such mailing or delivery. Such address may be changed at any time by a written notice signed by the Contractor and delivered to the Engineer.

**RECOVERY OF DAMAGES:** The making of an estimate and payment in accordance therewith shall not preclude the District from demanding and recovering from the Contractor such damages as it may sustain by reason of the Contractor's failure to comply with the Specifications.

**MONIES MAY BE RETAINED:** The District may keep any monies which would otherwise be payable at any time hereunder and apply the same, or so much as may be necessary therefor, to the payment of any expenses, losses, or damages, as determined by the Engineer, incurred by the District, for which the Contractor is liable under the contract.

**SALES AND/OR TAXES:** Except as may be otherwise specifically provided herein, all sales and/or use taxes assessed by federal, state, or local authorities on materials used or furnished by the Contractor in performing the work hereunder shall be paid by the Contractor.

**ALLOWABLE VARIATION:** When in these Specifications a maximum or minimum, either in size, percentage, or thickness or relating to quality, character, or other matter, is allowed or prescribed, the work shall be accepted as in compliance if within such maximum or minimum so allowed thereby.

**PROTECTION OF PUBLIC UTILITIES:** The Contractor shall not be assessed liquidated damages for delay in completion of the project when such delay is caused by failure of the District or owner of a public utility to provide for removal or relocation of existing utility facilities. This Agreement is subject to Government Code Sections 4215 and 4126 – 4216.9. Contractor must notify utilities and obtain an identification number before excavation or be subject to liability for damages to subsurface installations.

**EMERGENCY INFORMATION:** The names, addresses, and telephone numbers of the Contractor and subcontractors, or their representatives, shall be filed with the Parks Department, the District Fire Department, and the County Sheriff's Department prior to beginning work.

**EMPLOYMENT OF APPRENTICES:** The Contractor's attention is directed to the provisions of Sections 1777.5 and 1777.6 of the Labor Code concerning the employment of apprentices by the Contractor or any Subcontractor under the Contractor. The Contractor, and any subcontractor under the Contractor, shall comply with the requirements of all statutory provisions relating to the employment of apprentices. Information relative to apprenticeship standards and administration of the apprenticeship program may be obtained from the Director of Industrial Relations, P.O. Box 603, San Francisco, California 94101 or from the Division of Apprenticeship Standards and its branch offices.

**PENALTIES FOR DISCRIMINATION IN EMPLOYMENT:** Any Contractor who shall be found in violation of the nondiscrimination provisions of the State of California Fair Employment Practices Act or similar provisions of federal law or executive order in the performance of any contract with the District shall be found in material breach of such contract and the District shall have power to cancel or suspend the Contractor, in whole or in part, or to deduct from the amount payable to such Contractor the sum of twenty-five dollars (\$25.00) for each person for each calendar day during which such person was discriminated against, as damages for said breach of contract; or both. Only a finding of the State of California Fair Employment Practices Commission or the equivalent federal agency or officer shall constitute evidence of a violation of contract under this section.

The Contractor shall enclose with his or her bid a Compliance Report stating that he or she will pursue an affirmative course of action as required by the affirmative action guidelines.

**PROVISIONS REQUIRED BY LAW DEEMED INSERTED:** Each and every provision of law and clause required by law to be inserted in this contract shall be deemed to be inserted herein,

and the contract shall be read and enforced as though it were included herein. If through mistake or otherwise any such provision is not inserted, or is not correctly inserted, then upon application of either party, the contract shall forthwith be physically amended to make such insertion or correction.

**PAYROLL RECORDS:** The Contractor's attention is directed to the following provisions of Labor Code Section 1776, "Payroll record of wages paid; Inspections; Forms; Effect of noncompliance; Penalties". The Contractor shall be responsible for the compliance with these provisions by his or her subcontractors.

"(a) Each contractor and subcontractor shall keep an accurate payroll record, showing the name, address, social security number, work classification, straight time and overtime hours worked each day and week, and the actual per diem wages paid to each journeyman, apprentice, worker, or other employee employed by him or her in connection with the public work. Each payroll record shall contain or be verified by a written declaration that it is made under penalty of perjury, stating both of the following:

- (1) The information contained in the payroll record is true and correct.
- (2) The employer has complied with the requirements of Sections 1771, 1811, and 1815 for any work performed by his or her employees on the public works project.

(b) The payroll records enumerated under subdivision (a) shall be certified and shall be available for inspection at all reasonable hours at the principal office of the contractor on the following basis:

- (1) A certified copy of an employee's payroll record shall be made available for inspection or furnished to the employee or his or her authorized representative on request.
- (2) A certified copy of all payroll records enumerated in subdivision (a) shall be made available for inspection or furnished upon request to a representative of the body awarding the contract and the Division of Labor Standards Enforcement of the Department of Industrial Relations.
- (3) A certified copy of all payroll records enumerated in subdivision (a) shall be made available upon request to the public for inspection or for copies thereof. However, a request by the public shall be made through either the body awarding the contract or the Division of Labor Standards Enforcement. If the requested payroll records have not been provided pursuant to paragraph (2), the requesting party shall, prior to being provided the records, reimburse the costs of preparation by the contractor, subcontractors, and the entity through which the request was made. The public may not be given access to such records at the principal office of the contractor.

(c) Unless required to be furnished directly to the Labor Commissioner in accordance with paragraph (3) of subdivision (a) of Section 1771.4, the certified payroll records shall be on forms provided by the Division of Labor Standards Enforcement or shall contain the same information as the forms provided by the division. The payroll records may consist of printouts of payroll data that are maintained as computer records, if printouts contain the same information as the forms provided by the division and the printouts are verified in the manner specified subdivision (a).

(d) A contractor or subcontractor shall file a certified copy of the records enumerated in subdivision (a) with the entity that requested the records within 10 days after receipt of a written request.

(e) Except as provided in subdivision (f), any copy of records made available for inspection as copies and furnished upon request to the public or any public agency by the awarding body or the Division of Labor Standards Enforcement shall be marked or obliterated to prevent disclosure of an individual's name, address, and social security number. The name and address of the contractor awarded the contract or the subcontractor performing the contract shall not be marked or obliterated. Any copy of records made available for inspection by, or furnished to, a multiemployer Taft-Hartley trust fund (29 U.S.C. Sec. 175a) shall be marked or obliterated only to prevent disclosure of an individual's full social security number, but shall provide the last four digits of the social security number. Any copy of records made available for inspection by, or furnished to, a joint labor-management committee established pursuant to the federal Labor Management Cooperation Act of 1978 (29 U.S.C. Sec. 175a) shall be marked or obliterated only to prevent disclosure of an individual's social security number.

(f)(1) Notwithstanding any other provision of law, agencies that are included in the Joint Enforcement Strike Force on the Underground Economy established pursuant to Section 329 of the Unemployment Insurance Code and other law enforcement agencies investigating violations of law shall, upon request, be provided nonredacted copies of certified payroll records. Any copies of records or certified payroll made available for inspection and furnished upon request to the public by an agency included in the Joint Enforcement Strike Force on the Underground Economy or to a law enforcement agency investigating a violation of law shall be marked or redacted to prevent disclosure of an individual's name, address, and social security number.

(2) An employer shall not be liable for damages in a civil action for any reasonable act or omission taken in good faith in compliance with this subdivision.

(g) The contractor shall inform the body awarding the contract of the location of the records enumerated under subdivision (a), including the street address, city, and county, and shall, within five working days, provide a notice of a change of location and address.

(h) The contractor or subcontractor has 10 days in which to comply subsequent to receipt of written notice requesting the records enumerated in subdivision (a). In the event that the contractor or subcontractor fails to comply within the 10-day period, he or she shall, as a penalty to the state or political subdivision on whose behalf the contract is made or awarded, forfeit one hundred dollars (\$100) for each calendar day, or portion thereof, for each worker, until strict compliance is effectuated. Upon the request of the Division of Labor Standards Enforcement, these penalties shall be withheld from progress payments then due. A contractor is not subject to a penalty assessment pursuant to this section due to the failure of a subcontractor to comply with this section.

(i) The body awarding the contract shall cause to be inserted in the contract stipulations to effectuate this section.

(j) The director shall adopt rules consistent with the California Public Records Act (Chapter 3.5 (commencing with Section 6250) of Division 7 of Title 1 of the Government Code) and the

Information Practices Act of 1977 (Title 1.8 (commencing with Section 1798) of Part 4 of Division 3 of the Civil Code) governing the release of these records, including the establishment of reasonable fees to be charged for reproducing copies of records required by this section.

**ASSIGNMENT OF ANTITRUST ACTIONS:** The Contractor's attention is directed to the following provision of the Public Contracts Code, Section 7103.5, which shall be applicable to the Contractor and his or her subcontractors:

"(b) In entering into a public works contract or a subcontract to supply goods, services, or materials pursuant to a public works contract, the contractor or subcontractor offers and agrees to assign to the awarding body all rights, title, and interest in and to all causes of action it may have under Section 4 of the Clayton Act (15 U.S.C. Sec. 15) or under the Cartwright Act (Chapter 2 (commencing with Section 16700) of Part 2 Division 7 of Business and Professions Code), arising from purchases of goods, services, or materials pursuant to the public works contract or the subcontract. This assignment shall be made and become effective at the time the awarding body tenders final payment to the contractor, without further acknowledgment by the parties."

**CONSTRUCTION SCHEDULES:** Prior to issuing the "Notice to Proceed", the Engineer will schedule a preconstruction meeting with the Contractor to review the proposed construction schedule and delivery dates, arrange utility coordination, discuss construction methods, and clarify inspection procedures. The Contractor must provide to the Engineer, at the time of the preconstruction meeting, a schedule in the form of a Gantt Chart for review and approval. Any change in the construction schedule will require the Contractor to provide revised charts of those changes to the Engineer within two (2) working days. The "Notice to Proceed" will be issued upon approval of the project schedule. Requests for changes in the schedule shall be submitted by the Contractor to the Engineer in writing for approval at least 48 hours prior to the scheduled operations on the streets affected.

The schedule shall be broken down into activities by street with durations no greater than one week. No more than 15% of the activities may be on the critical path of the baseline schedule. The Engineer will review the baseline schedule and the Contractor will make any reasonable changes requested to make the schedule acceptable.

If at any time project completion is ten or more working days behind schedule, the Contractor shall submit a recovery schedule, subject to approval, showing how the original completion date will be met.

**CONSTRUCTION WORKING HOURS:** The Contractor's regular hours of work will be from 7:00 AM to 5:00 PM on all working days as defined in Section 1-2 of the Greenbook .

**EQUIVALENT MATERIALS:** Approval of equipment and materials offered as equivalents to those specified must be obtained in writing from the District prior to the opening of bids. Requests for consideration of equivalents must be submitted in writing allowing five (5) working days for complete consideration of all specifications, samples, references, tests, and other details to the full satisfaction of the District.



## **SPECIAL PROVISIONS**

### **PLEASANT VALLEY RECREATION & PARK DISTRICT**

### **SPRINGVILLE PARK FENCING REPAIR AND REPLACEMENT PROJECT**

**SPEC NO. SVPF-24-25**

**FISCAL YEAR 2024-2025**

#### **1. GENERAL**

**A. THE REQUIREMENT:** All work embraced herein shall be accomplished in accordance with the applicable portions of the "Standard Specifications for Public Works Construction" 2021 edition, plus any supplements, published, herein referred to as "Standard Specifications," except as modified by the General Conditions, these Special Provisions, Standard Drawings and the Project Plans ("Greenbook"). In addition to the above, the Contractor shall comply with the requirements of the following:

- (1) Notice Inviting Sealed Bids
- (2) Instructions to Bidders
- (3) Bid
- (4) Bid Bond
- (5) Information Required of Bidder
- (6) Agreement
- (7) Faithful Performance Bond
- (8) Payment Bond (Labor and Material Bond)

**B. DEFINITION OF TERMS:** Wherever in the Standard Specifications terms are used, they shall be understood to mean and refer to the following:

- (1) District – The Pleasant Valley Recreation & Park District
- (2) Board - The District's governing board
- (3) Director, Engineer - The District's Public Works and District Engineer, acting either directly or through authorized agents. Also referred to herein as District Engineer.
- (4) Other terms appearing in the Standard Specifications, the General Conditions, and these Special Provisions shall have the intent and meaning specified in Section 1 of the Standard Specifications.



**C. SCOPE AND CONTROL OF THE WORK:**

**PROJECT PLANS:** The location of the work, its general nature, extent, form and detail of the various features are shown on drawings accompanying and made a part of these specifications.

Section 2 is amended by adding thereto the following new Subsection 2-1.1 Plans and Specifications:

“2-1.1 Plans and Specifications. The Contractor shall maintain a control set of Plans and Specifications on the project site at all times. All final locations determined in the field, and any deviations from the Plans and Specifications, shall be marked in red on this control set to show the as-built conditions. Upon completion of all work, the Contractor shall return the control set to the Engineer. Final payment will not be made until this requirement is met.”

Section 2 is amended by adding thereto the following new Subsection 2-1.2 Record Drawings:

“2-1.2 Record Drawings.

All corrections on record drawings shall be done in red ink. Record drawings shall be a control set of the construction plans kept on the site for daily recording of “as built” conditions. Show dimensioned locations of all buried facilities, such as drains, sumps, pipe, valves, electrical conduits, and irrigation wires.

Dimensions must be taken from above ground permanent architectural objects, not plants or irrigation heads. All dimensions, notes, etc., shall be legible.

Record drawings shall be reviewed prior to all progress payment requests, and submitted prior to final inspection.”

**D. COMPLETION OF WORK:**

(1) All work to be done under this contract shall be completed within Thirty **(30) consecutive working days**, exclusive of maintenance periods, beginning on the date stipulated in the written "Notice to Proceed" issued by the Engineer.

(2) In the event that the Engineer is of the opinion that the work is being inadequately or improperly prosecuted in any respect, he or she may demand that the Contractor improve or change the prosecution of the work in such manner as to assure proper and timely completion.

**E. FINAL INVOICE AND PAYMENT:**

(1) Whenever in the opinion of the Engineer the Contractor shall have completely performed the contract on his or her part, the Engineer shall notify the District that the contract has been completed in its entirety. He or she shall request that the District accept the work and that the District of the Board be authorized to file, on behalf of the District, in the office of the Ventura County Recorder, a notice of completion of the work herein

agreed to be done by the Contractor. The Contractor will then submit to the Engineer for approval a written statement of the final quantities of contract items for inclusion in the final invoice. Upon receipt of such statement, the Engineer shall check the quantities included therein and shall authorize the Contractor to submit an invoice which in the Engineer's opinion shall be just and fair, covering the amount and value of the total amount of work done by the Contractor, not including the work that has already been invoiced by the Contractor. District will pay this invoice less any amounts District is required to withhold as described elsewhere in the Contract Documents.

(2) On the expiration of sixty (60) calendar days after recordation of the acceptance of the project by Ventura County Recorder, the District shall pay to the Contractor the amount remaining after deducting from the amount or value stated in the invoice all prior payments to the Contractor and all amounts to be kept and retained under the provisions of the contract and 150% of all disputed amounts, and shall release the faithful performance bond and the labor and material bond once all applicable disputes have been resolved. The District will comply with Public Contract Code Section 7107 and other applicable law regarding the release of retention.

**F. RETENTION:** The District will deduct a five percent (5%) retention from all progress payments as specified in Section 7-3.2 of the 2021 Standard Specifications for Public Works Construction.

**G. SUBSTITUTION OF SECURITIES FOR RETENTION:** Public Contract Code Section 22300 is hereby incorporated by reference. The substitution of securities for any moneys withheld by a public agency to ensure performance under a contract shall be permitted by the District.

**H. NO PERSONAL LIABILITY:** No agent of the Pleasant Valley Recreation & Park District shall be personally responsible for any liability arising under the contract. No claim shall be made or filed, and neither the District nor any of its agents shall be liable for, or held to pay money, except as specifically provided in the contract.

**I. UNPAID CLAIMS:** If, upon or before the completion of the work herein agreed to be performed or at any time prior to the expiration of the period within which claims of lien may be filed for record as prescribed by Civil Code Section 8416, any person or persons claiming to have performed any labor or furnished any material, supplies, or services toward the performance or completion of this contract or that they have agreed to do so, shall file with the District a verified statement of such claim, stating in general terms the kind of labor and materials and the name of the person to or for whom the same was done or furnished, or both, and the amount in value, as near as may be, of that already done or furnished, or both, together with a statement that the same has not been paid, or if any person or persons shall bring against the District or against any agent or agents thereof any action to enforce such claim, the District shall until the discharge thereof withhold from the moneys under its control so much of said moneys due or to become due the Contractor under this contract as shall be sufficient to satisfy and discharge the amount in such notice or under such action claimed to be due, together with the costs thereof; provided, that if the District shall in its discretion permit the Contractor to file such additional bond as is authorized by

Civil Code Section 9364 in a sum equal to 125% of the amount of the claim, said moneys shall not thereafter be withheld on account of such claim.

**J. ADDITIONAL SURETY:** If during the continuance of the contract any of the sureties upon the faithful performance bond in the opinion of the Engineer are or become insufficient, he or she may require additional sufficient sureties which the Contractor shall furnish to the satisfaction of the Engineer within fifteen (15) days after notice and, in default thereof, the contract may be suspended and the work completed as provided in Section 6 of the Standard Specifications.

**K. NOISE CONTROL REQUIREMENTS:** The Contractor shall comply with all local sound control and noise level rules, regulations, and ordinances that apply to any work performed pursuant to the contract.

Each internal combustion engine, used for any purpose on the job or related to the job, shall be equipped with a muffler of a type recommended by the manufacturer. No internal combustion engine shall be operated on the project without said muffler. The noise level from the Contractor's operations, between the hours of 7:00 A.M. and 5:00 P.M., shall not exceed 86 dBA at a distance of fifty (50) feet. This requirement in no way relieves the Contractor from responsibility for complying with the District Code Chapter 8.20 "Noise Control" regulating noise level. Said noise level requirements shall apply to all equipment on the job or related to the job, including but not limited to trucks, transmit mixers, or transient equipment that may or may not be owned by the Contractor. The use of loud sound signals shall be avoided in favor of light warnings except those required by safety laws for the protection of personnel.

Full compensation for conforming to the requirements of this section shall be considered as included in the unit cost for the various contract items of work involved, and no additional compensation will be allowed therefor.

**L. PERMITS AND LICENSES:** The Contractor shall procure all permits and licenses, pay all charges and fees, and give all notices necessary and incident to the due and lawful prosecution of the work. The Contractor shall also ensure that all subcontractors obtain required permits and licenses.

The Environmental Quality Act of 1970 (Chapter 1433, Stats. 1970), as amended by Chapter 1154, Stats. 1972, may be applicable to permits, licenses, and other authorizations which the Contractor must obtain from local agencies in connection with performing the work of the contract. The Contractor shall comply with all applicable environmental laws and regulations and conditions on the project in obtaining such permits, licenses, and other authorizations, and they shall be obtained in sufficient time to prevent delays to the work, and in undertaking the construction of the project. Contractor shall also comply with all applicable mandatory standards and policies relating to energy efficiency.

In the event that the District has obtained permits, licenses, or other authorizations applicable to the work in conformance with the requirements in said Environmental Quality Act of 1970, the Contractor shall comply with the provisions of said permits, licenses, and other authorizations.

**M. PAYMENTS:** Attention is directed to Subsection 7-3.2 of the Standard Specifications for partial payment and final payment requirements. No partial payment will be made for any materials on hand which are furnished but not incorporated in the work.

**N. LEGAL ACTIONS AGAINST THE DISTRICT:** In the event litigation is brought against the District concerning compliance by the District with State or Federal laws, rules, or regulations applicable to highway work, the provisions of this section shall apply.

(1) If, pursuant to court order, the District prohibits the Contractor from performing all or any portion of the work, the delay will be considered a utility delay within the meaning of Subsection 4-2.5 of the Standard Specifications unless the contract is terminated as hereinafter provided, in which event compensation payable to the Contractor shall be determined in accordance with said termination provisions.

(2) If, pursuant to court order (other than an order to show cause) the District is prohibited from requiring the Contractor to perform all or any portion of the work, the District may, if it so elects, eliminate the enjoined work pursuant to Section 2-7 of the Standard Specifications or terminate the contract in accordance with Subsections 6-6 and 6-7 of the Standard Specifications.

(3) If the final judgment in the action prohibits the District from requiring the Contractor to perform all or any portion of the work, the District will either eliminate the enjoined work pursuant to Section 2-7 of the Standard Specifications or terminate the contract in accordance with Subsections 6-6 and 6-7 of the Standard Specifications.

(4) Termination of the contract and the total compensation payable to the Contractor in the event of termination shall be governed by the following:

(a) The Engineer will issue the Contractor a written notice specifying that the contract is to be terminated. Upon receipt of said written notice and, except as otherwise directed in writing by the Engineer, the Contractor shall:

[1] Stop all work under the contract, except that portion of the work specifically directed to be completed prior to acceptance.

[2] Perform work the Engineer deems necessary to secure the project for termination.

[3] Remove equipment and plan from the site of the work.

[4] Take such action as is necessary to protect materials from damage.

[5] Notify all Subcontractors and suppliers that the contract is being terminated and that their contracts or orders are not to be further performed unless otherwise authorized in writing by the Engineer.

[6] Provide the Engineer with an inventory list of all materials previously produced, purchased, or ordered from suppliers for use in the work and not yet used in the work, including its storage location and such other information as the Engineer may request.

[7] Dispose of materials not yet used in the work as directed by Engineer. It shall be the Contractor's responsibility to provide the District with good title to all materials purchased by the District hereunder, including materials for which partial payment has been made as provided in Subsection 7-3.2 of the Standard Specifications, and with bills of sale or other documents of title for such materials.

[8] Subject to the prior written approval of the Engineer, settle all outstanding liabilities and all claims arising out of subcontracts or orders for materials terminated hereunder. To the extent directed by the Engineer, the Contractor shall assign to the District all the right, title, and interest of the Contractor under subcontracts or orders for materials terminated hereunder.

[9] Furnish the Engineer with the documentation required to be furnished by the Contractor under the provisions of the contract including, on projects as to which Federal funds are involved, all documentation required under the Federal requirements included in the contract.

[10] Take such other actions as the Engineer may direct.

(b) Acceptance of the contract as hereinafter specified shall not relieve the Contractor of responsibility for damage to materials except as follows:

[1] The Contractor's responsibility for damage to materials for which partial payment has been made as provided in Subsection 7-3.2 of the Standard Specifications, and for materials furnished by the District for use in the work and unused, shall terminate when the Engineer certifies that such materials have been stored in the manner and at the locations he or she has directed.

[2] The Contractor's responsibility for damage to materials purchased by the District subsequent to the issuance of the notice that the contract is to be terminated shall terminate when title and delivery of the materials has been taken by the District.

[3] When the Engineer determines that the Contractor has completed the work under the contract directed to be completed prior to termination and such other work as may have been ordered to secure the project for termination, he or she will recommend that the Engineer formally accept the contract, and immediately upon and after such acceptance by the

Engineer, the Contractor will not be required to perform any further work thereon and shall be relieved of his or her contractual responsibilities for injury to persons or property which occurs after the formal acceptance of the project by the Engineer.

(c) The total compensation to be paid to the Contractor shall be determined by the Engineer on the basis of the following:

[1] The reasonable cost to the Contractor, without profit, for all work performed under the contract, including mobilization, demobilization, and work done to secure the project for termination. Reasonable cost will include a reasonable allowance for project overhead and general administrative overhead not to exceed a total of seven percent (7%) of direct costs of such work.

When in the opinion of the Engineer, the cost of a contract item of work is excessively high due to costs incurred to remedy or replace defective or rejected work, the reasonable cost to be allowed will be the estimated reasonable cost of performing such work in compliance with the requirements of the plans and specifications and the excessive actual cost shall be disallowed.

[2] A reasonable allowance for profit on the cost of the work performed as determined under Subsection (a), provided the Contractor establishes to the satisfaction of the Engineer that it is reasonably probable that he or she would have made a profit had the contract been completed and provided further that the profit allowed shall in no event exceed four percent (4%) of said cost.

[3] The reasonable cost to the Contractor of handling material returned to the vendor, delivered to the District, or otherwise disposed of as directed by the Engineer.

[4] A reasonable allowance for the Contractor's administrative costs in determining the amount payable due to termination of the contract.

All records of the Contractor and his or her subcontractors, necessary to determine compensation in accordance with the provisions of this section, shall be open to inspection or audit by representatives of the District at all times after issuance of the notice that the contract is to be terminated and for a period of three years, and such records shall be retained for that period.

After acceptance of the work by the Engineer, the Engineer may make payments on the basis of interim estimates pending issuance of the Final Estimate when in his or her opinion the amount thus paid, together with all amounts previously paid, will not result in total compensation in excess of

that to which the Contractor will be entitled. All payments, including payment upon the Final Estimate, shall be subject to deduction for prior payments and amounts, if any, to be kept or retained under the provisions of the contract.

The provisions of this section shall be included in all subcontracts.

**O. TRENCHING:** In accordance with Section 6705 of the California Labor Code,

No contract for public works involving an estimated expenditure in excess of twenty-five thousand dollars (\$25,000), for the excavation of any trench or trenches five feet or more in depth, shall be awarded unless it contains a clause requiring submission by the Contractor and acceptance by the awarding body or by a registered civil or structural engineer employed by the awarding body, to whom authority to accept has been delegated, in advance of excavation, of a detailed plan showing the design of shoring, bracing, sloping, or other provisions to be made for worker protection from the hazard of caving ground during the excavation of such trench or trenches. If such plan varies from the shoring system standards, the plan shall be prepared by a registered civil or structural engineer.

Nothing in this section shall be deemed to allow the use of a shoring, sloping, or protective system less effective than that required by the Construction Safety Orders.

Nothing in this section shall be construed to impose tort liability on the awarding body or any of its employees.

The terms "public works" and "awarding body," as used in this section, shall have the same meaning as in Sections 1720 and 1722, respectively, of the Labor Code."

In addition, pursuant to Public Contracts Code § 7104, if the project involves digging trenches or other excavations that extend deeper than four feet below the surface:

(a) That the contractor shall promptly, and before the following conditions are disturbed, notify the local public entity, in writing, of any:

(1) Material that the contractor believes may be material that is hazardous waste, as defined in Section 25117 of the Health and Safety Code, that is required to be removed to a Class I, Class II, or Class III disposal site in accordance with provisions of existing law.

(2) Subsurface or latent physical conditions at the site differing from those indicated by information about the site made available to bidders prior to the deadline for submitting bids.

(3) Unknown physical conditions at the site of any unusual nature, different materially from those ordinarily encountered and generally recognized as inherent in work of the character provided for in the contract.

(b) That the local public entity shall promptly investigate the conditions, and if it finds that the conditions do materially so differ, or do involve hazardous waste, and cause a decrease or increase in the contractor's cost of, or the time required for, performance of any part of the work shall issue a change order under the procedures described in the contract.

(c) That, in the event that a dispute arises between the local public entity and the contractor whether the conditions materially differ, or involve hazardous waste, or cause a decrease or increase in the contractor's cost of, or time required for, performance of any part of the work, the contractor shall not be excused from any scheduled completion date provided for by the contract, but shall proceed with all work to be performed under the contract. The contractor shall retain any and all rights provided either by contract or by law which pertain to the resolution of disputes and protests between the contracting parties."

Full compensation for sheeting, shoring, bracing, sloping, and all other provisions required for worker protection shall be considered as included in the contract price shown in the appropriate Bid Item, and no additional compensation will be allowed therefor.

**P. CHANGES IN WORK:**

The following Section is hereby added:

"7.4.3.3 Mark-up Cap. Work by the Subcontractor the Contractor's total mark-up is not to exceed 12%."

**Q. CONTROL OF MATERIALS:**

The following sections are added to Section 4:

"4-1.1 General. The Contractor and all subcontractors, suppliers, and vendors shall guarantee that all work performed under this contract fully meets the requirements thereof as to quality of workmanship. Should any defects become evident within a period of one year from the date of the acceptance of the work by the District's Board, the Contractor shall, at his or her own expense, make any repair or replacement necessary to restore the work to full compliance with these Special Provisions.

Such repair and replacement shall be made promptly upon receipt of written notice from the Engineer. If the Contractor fails to make such repair and replacement promptly, the Engineer may cause the work to be done and the costs incurred thereby shall become the liability of the Contractor and his or her Surety.

If, in the opinion of the Engineer, defective work creates a dangerous condition or requires immediate correction or attention to prevent further loss by the District or to prevent interruption of operations of the District, the District will attempt to give the notice required by this article. If the Contractor cannot be contacted or does not comply with the Engineer's request for correction within a reasonable time as



determined by the Engineer, the District may, notwithstanding the provisions of this article, proceed to make such correction or attention and the costs of such correction or attention shall be charged against the Contractor.

The foregoing obligation shall be secured by the surety bond in a form approved by the Engineer in an amount not less than ten (10%) of the final contract price or \$1,000.00, whichever is greater, and shall be delivered to the Engineer prior to final acceptance of the work. Payment for fulfilling the requirements of this section shall be considered as included in the unit cost for the various contract items of work, and no additional compensation will be allowed therefor.”

“4-4.1 Test of Materials. Except as elsewhere specified, the District will bear the cost of testing material and/or workmanship that meets or exceeds the requirements indicated in the project specifications contained herein, Standard Specifications and the Special Provisions. The cost of all other tests, including the retesting of material or workmanship that fails to pass the first test, shall be borne by the Contractor.”

Section 4-5 shall be replaced with the following:

“4-5 Certification. A Certificate of Compliance shall be furnished prior to the use of any materials for which these specifications or the special provisions require that such a certificate be furnished. In addition, when so authorized in these specifications or in the Special Provisions, the Engineer may permit the use of certain materials or assemblies prior to sampling and testing if accompanied by a Certificate of Compliance. The certificate shall be signed by the manufacturer of the material or the manufacturer of assembled materials and shall state that the materials involved comply in all respects with the requirements of the specifications. A Certificate of Compliance shall be furnished with each lot of material delivered to the work and the lot so certified shall be clearly identified in the certificate.”

**R. CARB Compliance.** For a project involving the use of in-use off-road diesel-fueled vehicles, as defined by 13 CCR 2449, Contractor shall obtain copies of the valid Certificates of Reported Compliance, as described in 13 CCR 2449(n), for the fleet performing services pursuant to this contract and all listed subcontractors, if applicable, prior to commencing any work pursuant to this Contract or any renewed contract with that fleet. Contractor shall indemnify, defend and hold harmless the District, its officers, agents, employees and directors from any liability imposed arising from Contractor’s violation of any regulation set forth in 13 CCR 2449.

**S. CONFERENCES AND MEETING:** When and as directed by the Engineer, the Contractor shall attend all conferences and meetings that the Engineer deems necessary for the proper progress of work under this contract.

**T. UNDERGROUND SERVICE ALERT:** Except in an emergency, the Contractor, prior to conducting any excavation or resurfacing, shall contact the appropriate regional notification

center, at least two working days prior to commencing that excavation or resurfacing. The regional notification center shall provide an inquiry center and shall notify any member, if known, who has a subsurface installation in the area of the proposed excavation or resurfacing.

Underground Service Alert may be contacted by calling 1-800-422-4133.

#### U. RESOLUTION OF ALL CONSTRUCTION CLAIMS:

##### **“9204. Legislative findings and declarations regarding timely and complete payment of contractors for public works projects; claims process**

(a) The Legislature finds and declares that it is in the best interests of the state and its citizens to ensure that all construction business performed on a public works project in the state that is complete and not in dispute is paid in full and in a timely manner.

(b) Notwithstanding any other law, including, but not limited to, Article 7.1 (commencing with Section 10240) of Chapter 1 of Part 2, Chapter 10 (commencing with Section 19100) of Part 2, and Article 1.5 (commencing with Section 20104) of Chapter 1 of Part 3, this section shall apply to any claim by a contractor in connection with a public works project.

(c) For purposes of this section:

(1) “Claim” means a separate demand by a contractor sent by registered mail or certified mail with return receipt requested, for one or more of the following:

(A) A time extension, including, without limitation, for relief from damages or penalties for delay assessed by a public entity under a contract for a public works project.

(B) Payment by the public entity of money or damages arising from work done by, or on behalf of, the contractor pursuant to the contract for a public works project and payment for which is not otherwise expressly provided or to which the claimant is not otherwise entitled.

(C) Payment of an amount that is disputed by the public entity.

(2) “Contractor” means any type of contractor within the meaning of Chapter 9 (commencing with Section 7000) of Division 3 of the Business and Professions Code who has entered into a direct contract with a public entity for a public works project.

(3)(A) “Public entity” means, without limitation, except as provided in subparagraph (B), a state agency, department, office, division, bureau, board, or commission, the California State University, the University of California, a city, including a charter city, county, including a charter county, city and county, including a charter city and county, district, special district, public authority, political subdivision, public corporation, or nonprofit transit corporation wholly owned by a public agency and formed to carry out the purposes of the public agency.

(B) “Public entity” shall not include the following:

(i) The Department of Water Resources as to any project under the jurisdiction of that department.

(ii) The Department of Transportation as to any project under the jurisdiction of that department.

(iii) The Department of Parks and Recreation as to any project under the jurisdiction of that department.

(iv) The Department of Corrections and Rehabilitation with respect to any project under its jurisdiction pursuant to Chapter 11 (commencing with Section 7000) of Title 7 of Part 3 of the Penal Code.

(v) The Military Department as to any project under the jurisdiction of that department.

(vi) The Department of General Services as to all other projects.

(vii) The High-Speed Rail Authority.

(4) "Public works project" means the erection, construction, alteration, repair, or improvement of any public structure, building, road, or other public improvement of any kind.

(5) "Subcontractor" means any type of contractor within the meaning of Chapter 9 (commencing with Section 7000) of Division 3 of the Business and Professions Code who either is in direct contract with a contractor or is a lower tier subcontractor.

(d)(1)(A) Upon receipt of a claim pursuant to this section, the public entity to which the claim applies shall conduct a reasonable review of the claim and, within a period not to exceed 45 days, shall provide the claimant a written statement identifying what portion of the claim is disputed and what portion is undisputed. Upon receipt of a claim, a public entity and a contractor may, by mutual agreement, extend the time period provided in this subdivision.

(B) The claimant shall furnish reasonable documentation to support the claim.

(C) If the public entity needs approval from its governing body to provide the claimant a written statement identifying the disputed portion and the undisputed portion of the claim, and the governing body does not meet within the 45 days or within the mutually agreed to extension of time following receipt of a claim sent by registered mail or certified mail, return receipt requested, the public entity shall have up to three days following the next duly publicly noticed meeting of the governing body after the 45-day period, or extension, expires to provide the claimant a written statement identifying the disputed portion and the undisputed portion.

(D) Any payment due on an undisputed portion of the claim shall be processed and made within 60 days after the public entity issues its written statement. If the public entity fails to issue a written statement, paragraph (3) shall apply.

(2)(A) If the claimant disputes the public entity's written response, or if the public entity fails to respond to a claim issued pursuant to this section within the time prescribed, the claimant may demand in writing an informal conference to meet and confer for settlement of the issues in dispute. Upon receipt of a demand in writing sent by registered mail or certified mail, return

receipt requested, the public entity shall schedule a meet and confer conference within 30 days for settlement of the dispute.

(B) Within 10 business days following the conclusion of the meet and confer conference, if the claim or any portion of the claim remains in dispute, the public entity shall provide the claimant a written statement identifying the portion of the claim that remains in dispute and the portion that is undisputed. Any payment due on an undisputed portion of the claim shall be processed and made within 60 days after the public entity issues its written statement. Any disputed portion of the claim, as identified by the contractor in writing, shall be submitted to nonbinding mediation, with the public entity and the claimant sharing the associated costs equally. The public entity and claimant shall mutually agree to a mediator within 10 business days after the disputed portion of the claim has been identified in writing. If the parties cannot agree upon a mediator, each party shall select a mediator and those mediators shall select a qualified neutral third party to mediate with regard to the disputed portion of the claim. Each party shall bear the fees and costs charged by its respective mediator in connection with the selection of the neutral mediator. If mediation is unsuccessful, the parts of the claim remaining in dispute shall be subject to applicable procedures outside this section.

(C) For purposes of this section, mediation includes any nonbinding process, including, but not limited to, neutral evaluation or a dispute review board, in which an independent third party or board assists the parties in dispute resolution through negotiation or by issuance of an evaluation. Any mediation utilized shall conform to the timeframes in this section.

(D) Unless otherwise agreed to by the public entity and the contractor in writing, the mediation conducted pursuant to this section shall excuse any further obligation under Section 20104.4 to mediate after litigation has been commenced.

(E) This section does not preclude a public entity from requiring arbitration of disputes under private arbitration or the Public Works Contract Arbitration Program, if mediation under this section does not resolve the parties' dispute.

(3) Failure by the public entity to respond to a claim from a contractor within the time periods described in this subdivision or to otherwise meet the time requirements of this section shall result in the claim being deemed rejected in its entirety. A claim that is denied by reason of the public entity's failure to have responded to a claim, or its failure to otherwise meet the time requirements of this section, shall not constitute an adverse finding with regard to the merits of the claim or the responsibility or qualifications of the claimant.

(4) Amounts not paid in a timely manner as required by this section shall bear interest at 7 percent per annum.

(5) If a subcontractor or a lower tier subcontractor lacks legal standing to assert a claim against a public entity because privity of contract does not exist, the contractor may present to the public entity a claim on behalf of a subcontractor or lower tier subcontractor. A subcontractor

may request in writing, either on their own behalf or on behalf of a lower tier subcontractor, that the contractor present a claim for work which was performed by the subcontractor or by a lower tier subcontractor on behalf of the subcontractor. The subcontractor requesting that the claim be presented to the public entity shall furnish reasonable documentation to support the claim. Within 45 days of receipt of this written request, the contractor shall notify the subcontractor in writing as to whether the contractor presented the claim to the public entity and, if the original contractor did not present the claim, provide the subcontractor with a statement of the reasons for not having done so.

(e) The text of this section or a summary of it shall be set forth in the plans or specifications for any public works project that may give rise to a claim under this section.

(f) A waiver of the rights granted by this section is void and contrary to public policy, provided, however, that (1) upon receipt of a claim, the parties may mutually agree to waive, in writing, mediation and proceed directly to the commencement of a civil action or binding arbitration, as applicable; and (2) a public entity may prescribe reasonable change order, claim, and dispute resolution procedures and requirements in addition to the provisions of this section, so long as the contractual provisions do not conflict with or otherwise impair the timeframes and procedures set forth in this section.

(g) This section applies to contracts entered into on or after January 1, 2017.

(h) Nothing in this section shall impose liability upon a public entity that makes loans or grants available through a competitive application process, for the failure of an awardee to meet its contractual obligations.

(i) This section shall remain in effect only until January 1, 2027, and as of that date is repealed, unless a later enacted statute that is enacted before January 1, 2027, deletes or extends that date.”

#### **RESOLUTION OF CONSTRUCTION CLAIMS OF \$375,000 OR LESS:**

##### **“20104. Application of article; provisions included in plans and specifications**

(a) (1) This article applies to all public works claims of three hundred seventy-five thousand dollars (\$375,000) or less which arise between contractor and a local agency.

(2) This article shall not apply to any claims resulting from a contract between a contractor and a public agency when the public agency has elected to resolve any disputes pursuant to Article 7.1 (commencing with Section 10240) of Chapter 1 of Part 2.

(b) (1) "Public work" means "public works contract" as defined in Section 1101 but does not include any work or improvement contracted for by the State or the Regents of the University of California.

(2) "Claim" means a separate demand by the contractor for (A) a time extension, (B) payment of money or damages arising from work done by or on behalf of, the contractor

pursuant to the contract for a public work and payment of which is not otherwise expressly provided for or the claimant is not otherwise entitled to, or (C) an amount the payment of which disputed by the local agency.

(c) The provisions of this article or a summary thereof shall be set forth in the plans or specifications for any work which may give rise to a claim under this article.

(d) This article applies only to contracts entered into on or after January 1, 1991.”

**“20104.2. Claims; requirements; tort claims excluded**

For any claim subject to this article, the following requirements apply:

(a) The claim shall be in writing and include the documents necessary to substantiate the claim. Claims must be filed on or before the date of final payment. Nothing in this subdivision is intended to extend the time limit or supersede notice requirements otherwise provided by contract for the filing of claims.

(b) (1) For claims of less than fifty thousand dollars (\$50,000), the local agency shall respond in writing to any written claim within 45 days of receipt of the claim, or may request, in writing, within 30 days of receipt of the claim, any additional documentation supporting the claim or relating to defenses to the claim the local agency may have against the claimant.

(2) If additional information is thereafter required, it shall be requested and provided pursuant to this subdivision, upon mutual agreement of the local agency and the claimant.

(3) The local agency's written response to the claim, as further documented, shall be submitted to the claimant within 15 days after receipt of the further documentation or within a period of time no greater than that taken by the claimant in producing the additional information, whichever is greater.

(c) (1) For claims of over fifty thousand dollars (\$50,000) and less than or equal to three hundred seventy-five thousand dollars (\$375,000), the local agency shall respond in writing to all written claims within 60 days of receipt of the claim, or may request, in writing, within 30 days of receipt of the claim, any additional documentation supporting the claim or relating to defenses to the claim the local agency may have against the claimant.

(2) If additional information is thereafter required, it shall be requested and provided pursuant to this subdivision, upon mutual agreement of the local agency and the claimant.

(3) The local agency's written response to the claim, as further documented, shall be submitted to the claimant within 30 days after receipt of the further documentation, or within a period of time no greater than that taken by the claimant in producing the additional information or requested documentation, whichever is greater.

(d) If the claimant disputes the local agency's written response, or the local agency fails to respond within the time prescribed, the claimant may so notify the local agency, in writing, either within 15 days of receipt of the local agency's response or within 15 days of the local agency's failure to respond within the time prescribed, respectively, and demand an informal conference to meet and confer for settlement of the issues in dispute. Upon a demand, the local agency shall schedule a meet and confer conference within 30 days for settlement of the dispute.

(e) Following the meet and confer conference the claim or any portion remains in dispute, the claimant may file a claim as provided in Chapter 1 (commencing with Section 900) and Chapter 2 (commencing with Section 910) of Part 3 of Division 3.6 of Title 1 of the Government Code. For purposes of those provisions, the running of the period of time within which a claim must be filed shall be tolled from the time the claimant submits his or her written claim pursuant to subdivision (a) until the time that claim is denied as a result of the meet and confer process, including any period of time utilized by the meet and confer process.

(f) This article does not apply to tort claims and nothing in this article is intended nor shall be construed to change the time periods for filing tort claims or actions specified by Chapter 1 (commencing with Section 900) and Chapter 2 (commencing with Section 910) of Part 3 of Division 3.6 of Title 1 of the Government Code.”

**“20104.4. Civil action procedures; mediation and arbitration; trial de novo; witnesses**

The following procedures are established for all civil actions filed to resolve claims subject to this article:

(a) Within 60 days, but no earlier than 30 days, following the filing or responsive pleadings, the court shall submit the matter to nonbinding mediation unless waived by mutual stipulation of both parties. The mediation process shall provide for the selection within 15 days by both parties of a disinterested third person as mediator, shall be commenced within 30 days of the submittal, and shall be concluded within 15 days from the commencement of the mediation unless a time requirement is extended upon a good cause showing to the court or by stipulation of both parties. If the parties fail to select a mediator within the 15-day period, any party may petition the court to appoint the mediator.

(b) (1) If the matter remains in dispute, the case shall be submitted to judicial arbitration pursuant to Chapter 2.5 (commencing with Section 1141.10) of Title 3 of Part 3 of the Code of Civil Procedure, notwithstanding Section 1141.11 of that code. The Civil Discovery Act (Title 4 (commencing with Section 2016.010), of the Code of Civil Procedure) shall apply to any proceeding brought under this subdivision consistent with the rules pertaining to judicial arbitration.

(2) Notwithstanding any other provision of law, upon stipulation of the parties, arbitrators appointed for purposes of this article shall be experienced in construction law, and, upon stipulation of the parties, mediators and arbitrators shall be paid necessary and reasonable hourly rates of pay not to exceed their customary rate, and such fees and expenses shall be paid equally by the parties, except in the case of arbitration where the

arbitrator, for good cause, determines a different division. In no event shall these fees or expenses be paid by state or county funds.

(3) In addition to Chapter 2.5 (commencing with Section 1141.10) of Title 3 of Part 3 of the Code of Civil Procedure, any party who after receiving an arbitration award requests a trial de novo but does not obtain a more favorable judgment shall, in addition to payment of costs and fees under that chapter, pay the attorney's fees of the other party arising out of trial de novo.

(c) The court may, upon request by any party, order any witnesses to participate in the mediation or arbitration process.”

**“20104.6. Payment on undisputed portion of claim; interest on arbitration award or judgment**

(a) No local agency shall fail to pay money as to any portion of a claim which is undisputed except as otherwise provided in the contract.

(b) In any suit filed under Section 20104.4, the local agency shall pay interest at the legal rate on any arbitration award or judgment. The interest shall begin to accrue on the date the suit is filed in a court of law.”

**W. WORKING HOUR RESTRICTIONS:** Eight hours' labor is a legal day's work. Any workers time of service is restricted to eight hours during any calendar day and forty hours during any calendar week, unless overtime compensation is paid at not less than one and one-half times the basic rate of pay. The Contractor or Subcontractor shall, as a penalty to the District forfeit twenty-five dollars (\$25) for each worker employed in the execution of the contract by the respective Contractor or subcontractor for each calendar day during which the worker is required or permitted to work more than eight hours in any one calendar day and forty hours in any one calendar week in violation of the law.

**X. EXAMINATION AND AUDIT:** All documents and records that relate in any way to this Agreement shall be maintained for a period of three years after the final payment under this Agreement. These records shall be subject to the examination and audit by the District and by the State Auditor, at the request of the District or as part of any audit of the District, for a period of three years after final payment under the Agreement.

**Y. DELAYS AND EXTENSIONS OF TIME**

6-4.4 Written Notice and Report. The first sentence of subsection 6-6.4 is hereby deleted and replaced with the following:

“If the Contractor desires payment for a delay as specified in Subsection 6-6.3 of the Standard Specifications, it shall notify the Engineer in writing within 3 days of the beginning of the delay. If the Contractor desires an extension of time as specified in Subsection 6-4.2 of the Standard Specifications, it shall notify the Engineer in writing



within 3 days of the beginning of the delay. Such notice shall specify the nature of the delay, cause, and the conditions that set the beginning time for the delay.”

## **Z. PROTECTION AND RESTORATION OF EXISTING IMPROVEMENTS**

The second paragraph of Subsection 400-1 of the Standard Specifications is hereby deleted and replaced with the following:

“The Contractor shall relocate, repair, replace, or reestablish all existing improvements within the project area which are not designated for removal (e.g., curbs, sidewalks, driveways, fences, walls, sprinkler systems, signs, utility installations, pavements, structures, etc.) which are damaged or removed as a result of his or her operations or as required by the Plans and Specifications.

Where existing traffic striping, pavement markings, and curb markings are damaged or their reflectivity reduced by the Contractor's operations, such striping or markings shall also be considered as existing improvements and the Contractor shall repaint or replace such improvements.

Relocations, repairs, replacements, or reestablishments shall be at least equal to the existing improvements and shall match such improvements in finish and dimensions unless otherwise specified.”

Subsection 400-1.1 of the Standard Specifications is hereby added to read as follows:

“All costs to the Contractor for protecting, removing, restoring, relocating, repairing, replacing, or reestablishing existing improvements shall be included in the unit cost for the various items of work and no additional compensation will be allowed therefore.”

## **2. PUBLIC CONVENIENCE AND SAFETY**

**A. GENERAL:** In addition to the requirements specified in Part 6 of the Standard Specifications, traffic control shall conform to the provisions of the latest edition of the State of California, Department of Transportation, "Manual of Traffic Controls."

The Contractor shall give one week advance notice prior to the start of construction to all residences and businesses facing or siding on the construction area. Said notice shall be in writing on the Contractor's letterhead and shall explain in concise terms the extent and nature of the Work, the anticipated schedule, and office and emergency telephone numbers where the Contractor's representative can be reached.

Should the Contractor appear to be neglectful or negligent in furnishing warning and protective measures, the Engineer may direct attention to the existence of a hazard and the necessary warning and protective measures shall be furnished and installed immediately by the Contractor at his or her expense.

Should the Engineer point out the inadequacy of warning and protective measures, such action on the part of the Engineer shall not relieve the Contractor from responsibility for public safety or abrogate his or her obligation to furnish and pay for these devices.

If the Contractor cannot be contacted or if attention is directed to the existence of a hazard and the Contractor fails to provide the necessary safety devices, said devices will be placed, or caused to be placed, by the District. The cost of placement to these devices shall be the sole responsibility of the Contractor and shall be paid for at the rate of \$50 per call-out plus \$25 per traffic control device for each 24 hours, or fraction thereof, that the device is required. Said costs shall be deducted from the total contract price for the work.

Prior to beginning any construction, the Contractor shall furnish the Engineer with local emergency phone numbers where he or she or a representative may be contacted during non-working hours or days for the purpose of replacing or providing additional warning or safety devices as directed by the Engineer.

**B. UTILITIES:** It is anticipated that the existing utilities will not interfere with the Contractor's construction operations. However, the Contractor shall exercise due care to ensure that the utility facilities are not damaged during his or her operations, and must notify utilities and obtain an identification number before excavation or be subject to liability for damages to subsurface installations. When in doubt, the Contractor shall contact the utility concerned before proceeding further.

Upon completion of the project, the Contractor shall be responsible to remove all painted utility markings, whether done by him or her or the respective utility owners on behalf of the contractor for this project work, from the surfaces of sidewalks, driveway approaches, curbs and gutters using the removal method acceptable to the Engineer. Any damage to sidewalks, driveway approaches, curbs and gutters due to the Contractor's removal operation shall be repaired at the Contractor's expense and to the satisfaction of the Engineer. Payment for removing utility markings shall be included in other items of work, and no additional compensation will be allowed therefore.

**C. LOCATION:** The location and existence of any underground utility or substructure, if shown on Plans, was obtained from a search of available records. No guarantee is made or implied that the information is complete or accurate. It shall be the Contractor's responsibility alone to determine the exact location of underground utilities or substructures of every nature and to protect them from damage. The Contractor shall excavate and expose all high-risk underground facilities.

The Contractor shall notify the owners of all utilities and substructures as set forth in the General Provisions.

**D. RELOCATION:** The second sentence of the last paragraph of Subsection 402-4 of the Standard Specifications is hereby deleted and replaced with the following:

“When not otherwise required by the Plans and Specifications and when directed by the Engineer, the Contractor shall arrange for the relocation of service connections, as necessary, between the meter and property line, or between the meter and limits of construction.

The Contractor shall be compensated for the costs of locating and repairing, removing and relocating utility facilities, provided that any damage is not due to the failure of the Contractor or subcontractor to exercise reasonable care and the utility facilities were not indicated in the plans and specifications with reasonable accuracy. The Contractor shall not be assessed liquidated damages for delay in completion of the project, when such delay was caused by the failure of the District or the owner of the utility to provide for removal or relocation of such utility facilities.”

**E. DELAYS:** The second paragraph of Subsection 402-5 is hereby deleted and replaced with the following two paragraphs:

“The Contractor will not be entitled to damages or additional payment for delays attributable to utility relocations or alterations if correctly located, noted and completed in accordance with Subsection 402-1. The Contractor shall ascertain further detailed information to coordinate his or her work to this effect.

All notification of utility companies shall be by the Engineer based on Contractor's request as submitted to the Engineer at least 72 hours in advance of the needed work. Any costs for delay of the Contractor or utility companies in this regard shall be assigned to the Contractor, if these costs are a result of the Contractor's request being untimely in any respect, except for the utility company not responding at their agreed time.”

**F. AIR POLLUTION CONTROL**

Section 3-12.2, "Air Pollution", of the Standard Specifications is supplemented by the following:

“The Contractor shall comply with all air pollution control rules, regulations, ordinances and statutes which apply to any work performed pursuant to the contract including any air pollution control, rules, regulations, ordinances and statutes specified in Section 11017 of the Government Code.

In the absence of any applicable air pollution control rules, regulations, ordinances or statutes governing solvents, all solvents, including but not limited to the solvent portions of paints, thinners, curing compounds, and liquid asphalt used on the project shall comply with the applicable material requirements of the County Air Pollution Control District. All containers of paint, thinner, curing compound or liquid asphalt shall be labeled to indicate that the contents fully comply with said requirements.”

**G. WATER POLLUTION:** The Contractor shall comply with the requirements of Subsection 3-12.6 of the Standard Specifications and shall conduct his or her operations so as to prevent portland cement, mud, silt or other materials from entering the surface drainage structures of the adjoining street and any underground storm drainage system.

Full compensation for prevention of water pollution and all required control work for preservation, clean-up and restoration of damaged property shall be considered as included in the unit cost for the various contract items of work, and no additional compensation will be allowed therefor.

**H. PROJECT APPEARANCE:** The Contractor shall maintain a neat appearance to the work.

Full compensation for conforming to the provisions of this section not otherwise provided for shall be considered as included in unit cost for the various contract items of work involved and no additional compensation will be allowed therefor.

**I. WORK HOURS:** The Contractor's working hours shall be limited to the hours between 7:00 a.m. and 5:00 p.m., excluding recognized holidays. Deviation from normal working hours will not be allowed without prior consent of the District Engineer.

In the event work is allowed by the Engineer outside of the normal working hours, at the request of and for the benefit of the Contractor, inspection service fees may be levied against the Contractor at a rate of \$50.00 per hour, including travel time where applicable. The above charge may also be levied if inspection services are deemed necessary by the Engineer as a matter of public safety or to otherwise insure the quality of the work.

**J. CONSTRUCTION YARD:** It shall be the Contractor's responsibility to locate any storage sites for materials and equipment needed and such sites must be approved in advance by the Engineer and must be free of objectionable material. The Contractor must submit to the Engineer for approval any and all agreement(s) between the Contractor and the property owner(s) of said storage site(s) and/or construction site(s) for approval prior to the start of construction. Said agreement(s) must provide for the restoration of the site(s) by the Contractor prior to the filing of "Notice of Completion" by the Engineer. Full compensation shall be considered as included in unit cost for the various contract items of work involved and no additional compensation will be allowed therefor.

No equipment or material used for staging shall be allowed to be stored on any District property or city streets during non-work time. All stage equipment and/or material shall be stored offsite and if such location is used, it shall be submitted in writing and approved by the District Engineer. All costs associated with such staging and location shall be included in other bid items of work and no additional compensation will be allowed thereof.

**K. SANITARY CONVENIENCE:** Necessary sanitary facilities for the use of the workmen performing the work, properly secluded from public observation and in compliance with health ordinances and laws, shall be constructed and maintained by Contractor, in a manner approved by the Engineer, and the use of such facilities shall be strictly enforced by the Contractor.

**L. INSPECTION:** The Engineer, or his or her authorized agent, shall at all times have access to work during construction and shall be furnished, to the extent possible, complete information and all documentation to ascertain full knowledge regarding the progress, workmanship and character of materials used and employed in the work. Whenever required, the Contractor shall furnish to the District for test, and free of charge, samples of any one of the materials proposed to be used in the work. Said samples shall be delivered by the Contractor at the place within the

District designated by the Engineer. Rejected material must be immediately removed from the work by the Contractor and shall not again be brought back to the site of the improvement.

The Contractor shall notify the Engineer or his or her authorized agent forty-eight (48) hours in advance when he or she will require inspection for either material or work to be done.

The inspection of the work shall not relieve the Contractor of any of his or her obligations to fulfill the contract as prescribed. Defective work shall be made good, and unsuitable materials may be rejected, notwithstanding the fact that such defective work and unsuitable materials have been previously overlooked by the Engineer or his or her authorized agent and accepted or estimated for payment.

**M. RESPONSIBILITY OF THE DISTRICT:** The District shall not be held responsible for the care or protection of any material or parts of the work prior to final acceptance, except as expressly provided for in these Contract Documents.

**N. RECYCLING OF MATERIALS:** Contractor's Obligation. Recycling of asphalt concrete, portland cement concrete, aggregate base, and green waste (trees and shrubs) is required. The Contractor is required to recycle at least 50% of all recyclable materials. All recycled materials shall be weighed on a certified weigh scale with weight tickets showing project name. RECORDS OF DISPOSAL, INCLUDING WEIGHT OF MATERIALS, SHALL BE SUBMITTED TO THE DISTRICT ON A MONTHLY BASIS.

Prior to commencing work, the Contractor shall complete the "Construction and Demolition Waste Reduction and Recycling Plan" form and submit it to the Parks Department for review and approval. The Contractor will be expected to follow the approved Plan and document results during construction. At the completion of activities, the Contractor shall submit the "Construction and Demolition Waste Reduction and Recycling Report" form to the Public Works Department for review and approval of compliance with the Plans. The above-referenced forms are provided in Appendix 2.

The Contractor is obligated, under this contract, to recycle the waste material through an approved recycling plant. **In the event the Contractor fails to comply with the C&D requirements (at least 50%), three percent (3%) of the approved contract amount will be forfeited to the District by Contractor as a penalty.**

Payment for Recycling of Materials shall be included in the unit cost for the various contract items of work and no additional compensation will be allowed therefor.

**O. TRAFFIC AND ACCESS:** *The Contractor shall notify the occupants of all affected properties at least 48 hours prior to any temporary obstruction of access. Vehicular access to property line shall be maintained, except as required for construction for a reasonable period of time. No overnight closure of any driveway will be allowed, except as permitted by the Engineer. Temporary ramps for driveways shall be provided and maintained by the end of each working day and during the weekends. Temporary driveway ramps shall be constructed with crushed miscellaneous base as directed by the Engineer.*

Contractor shall maintain vehicular, bicycle, and pedestrian traffic access through the project area at all times. A minimum of one 12-foot wide traffic lane and a minimum of one 4-foot wide all-weather paved pedestrian walkway shall be provided at all times, except as permitted by the Engineer. During times when less than 2 lanes of traffic are provided, contractor shall provide traffic control for the entire duration there is less than 2 lanes. The traffic lanes shall be maintained on all-weather pavement and shall remain unobstructed.

**P. STREET CLOSURES, DETOURS, BARRICADES, PARKING:** Street closures will not be allowed, except as specifically permitted by the Engineer.

The Contractor shall prepare any traffic control or detour plans that may be required as directed by the Engineer.

Lane transitions shall conform to the Caltrans Traffic Manual, Section 5-08.4, "Transition Area."

Temporary traffic channelization shall be accomplished with delineators. Temporary striping will not be allowed unless specifically permitted by the Engineer. The Contractor shall prepare any plans that may be required for temporary striping to the satisfaction of the Engineer. In no event will temporary striping be allowed on finished pavement surfaces which are to remain.

The Contractor shall schedule an employee to police the temporary delineators and barricades within the travel way during weekday, nonworking hours and over Saturdays, Sundays, and holidays. Any corrective work required to be done by District forces shall be back charged to the Contractor based on the actual costs, plus District overhead and withheld from the final payment.

As specified in the General Provisions, the schedule shall be submitted to the Engineer for approval prior to commencing work. This schedule shall allow affected people ample "on-street" parking within a reasonable distance from their homes and businesses. Requests for changes in the schedule shall be made in accordance with the General Provisions.

Temporary "No Parking" signs shall be posted at least 24 hours, but no more than 48 hours, in advance of the work. The signs shall be placed no more than 250 feet apart on each side of the street and at shorter intervals if conditions warrant. Signs shall be posted only for the areas necessary to accomplish the work. The Contractor shall provide the signs and will be responsible for adding the dates and hours of closure to the signs, removal of the signs, and furnishing and placing of barricades, if necessary, for posting of signs. All signs shall be removed within 48 hours after the effective date.

Payment for STREET CLOSURES, DETOURS, BARRICADES, PARKING shall be considered as included in the unit cost for bid item: "Traffic Control" no additional compensation will be allowed therefor.

## TECHNICAL PROVISIONS

### PLEASANT VALLEY RECREATION & PARK DISTRICT

## SPRINGVILLE PARK FENCING REPAIR AND REPLACEMENT PROJECT SPEC NO. SVPF-24-25

**Location:**

- 1) Springville Park – 801 Via Zamora, Camarillo, CA. 93010

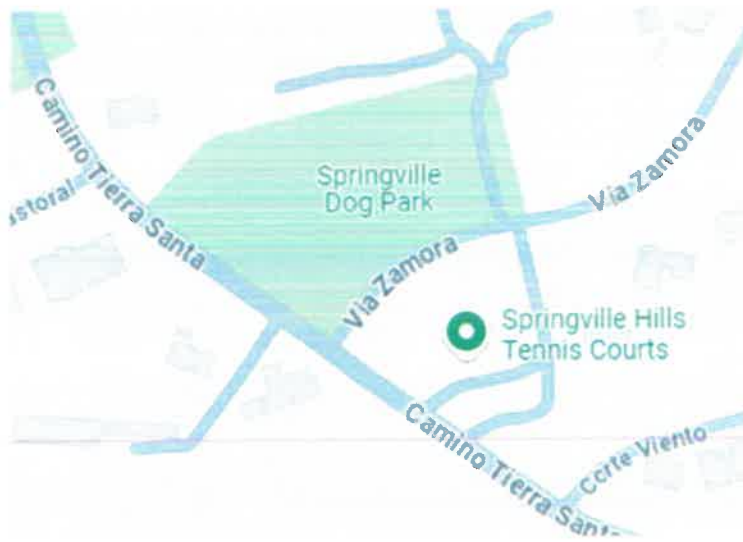

**See Attachments**

# Construction Specification

## For The Dog Park Wrought Iron Fencing Repair

### 1. GENERAL

#### 1.1 Scope of Work

- Repair and replace damaged wrought iron fence posts and panels along the designated sections.
- Approximately (14) ROTTEN fence panels and a total of 5 curved panels.

#### 1.2 Inspection and Assessment

- The contractor must inspect the existing fence and identify areas with rotted or damaged posts and panels that need replacement or repair.
- All sections needing repair must be documented with photographs and measurements.

#### 1.3 Submittals

- Product data sheets and technical specifications
- Shop drawings indicating fence layout, dimensions, and details
- Samples of fence panels, posts, and coatings if required

### 2. PRODUCTS

#### 2.1 Materials

- **Posts:** If necessary, any replacement posts must be 2"x2" (12 gage) square tubing, made of high-grade galvanized steel with (multi step process) powder coating finish for corrosion resistance.
- **Fence Panels:** Replacement panels should match the design and panels to be 38" height by approximately 8' wide, depending on existing post span. Rails must be 1-1/2"x 1-1/2" (14 gage) top and pickets must be 3/4"x 3/4" (14gage) square tubing pickets spaced at 4" max on centers. Use high-grade galvanized steel with (multi step process) powder coating finish for corrosion resistance.
- **Coating:** All existing wrought iron materials must be coated with a rust-resistant primer and finished with weather-resistant black enamel paint to match the new fence panels.

### 3. Repair and Replacement Specifications

- **Post Installation:** Remove damaged posts and install new ones securely into the existing CMU blocks. Any loose salvaged posts and new posts shall be grouted into



place for stability. Use non-shrink grout, suitable for structural applications in outdoor environments.

- **Post Caps:** Replace all post caps with new ones.
- **Panel Replacement:** Remove rotted fence panels and install new panels, ensuring secure attachment to the posts.
- **Welding Requirements:** All new attachments should be welded to match the existing construction. Welds should be ground smooth and treated to prevent rust.

#### 4. Safety Measures

- The contractor is responsible for setting up safety barriers or caution tape around the work area to prevent unauthorized access during repairs.
- All work must comply with applicable OSHA safety standards.

#### 5. Cleanup and Restoration

- Upon completion, the contractor must remove all debris, including old fence materials, from the site.
- The work area must be left clean and in good condition, with any damage to surrounding areas restored to pre-project conditions.

#### 6. Warranty and Guarantee

- The contractor must provide a warranty on labor and materials for a minimum of one year, covering any structural or workmanship defects in the repair.

#### Dog Park Fencing Map - Repair

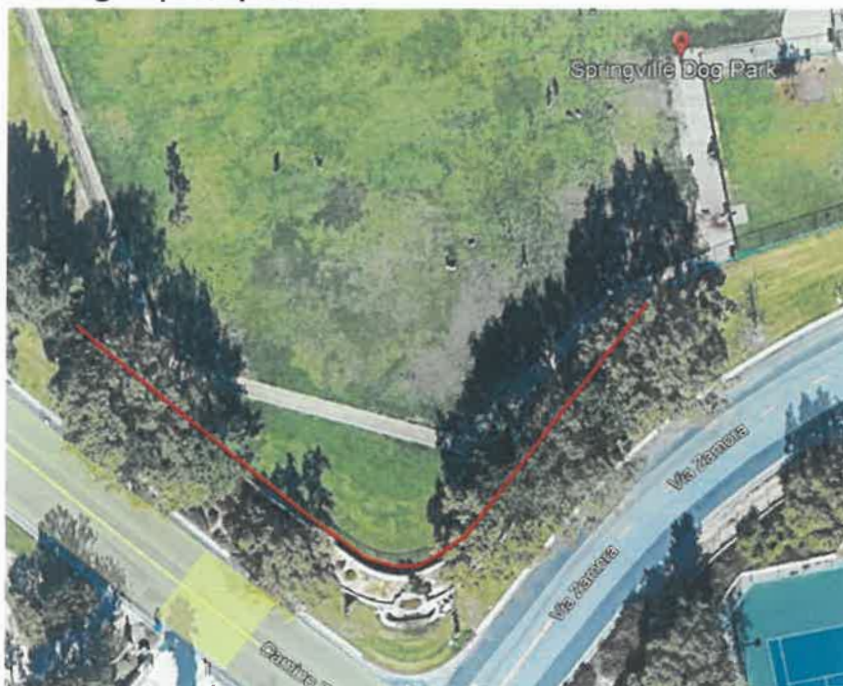

# Construction Specification

## For The Wrought Iron Fencing on The Tennis Court Side of Via Zamora Atop The Upper Retaining Wall.

**Product:** Montage Industrial® Steel Ornamental Fence System (Genesis Style) – Fusion Welded and Rackable

**Manufacturer:** Ameristar® Perimeter Security USA Inc.

---

### 1. GENERAL

#### 1.1 Scope

Remove approximately 250' of existing fencing in its entirety and replace it with 6' H Ameristar Montage Industrial® Steel Ornamental 3-Rail Fence System. Provide all labor, materials, equipment, and services necessary to install the Montage Industrial® steel ornamental fence system as specified.

#### 1.2 References

- ASTM A653/A653M: Standard Specification for Steel Sheet, Zinc-Coated
- ASTM B117: Practice for Operating Salt Spray (Fog) Apparatus
- ASTM D2794: Test Method for Resistance of Organic Coatings to the Effects of Rapid Deformation

#### 1.3 Submittals

- Product data sheets and technical specifications
- Shop drawings indicating fence layout, dimensions, and details
- Samples of fence panels, posts, and coatings if require

### 2. PRODUCTS

#### 2.1 Manufacturer

Ameristar Perimeter Security USA Inc., Tulsa, Oklahoma, or approved equal.

#### 2.2 Materials

- **Steel:** Pre-galvanized steel conforming to ASTM A653/A653M standards.
- **Fusion Welded Construction:** Panels shall be fusion-welded at all intersections to eliminate unsightly exposed welds.

## 2.3 Finish

- **Protective Coating:** E-coat corrosion protection system meeting or exceeding ASTM B117 standards for 1,000-hour salt spray resistance.
- **Powder Coating:** UV-resistant polyester powder coating for durability and color retention.

## 2.4 Fence Panels

- **Panel Height:** 6'
- **Panel Width:** As determined by existing post layout
- **Rail Design:** 3 rail design

## 2.5 Posts

- **Type:** Steel posts suitable for rackable panel attachment.
- **Dimensions:** 2.5" square 12ga.
- **Spacing:** Posts spaced as per manufacturer's recommendations for structural stability.

## 2.6 Accessories

- Brackets, caps, and fasteners shall be compatible with the fence system and corrosion resistant.

# 3. EXECUTION

## 3.1 Examination

- Verify the structural integrity of the CMU wall to support the new fence system.
- Inspect and document the condition of existing posts, grout, and CMU wall.
- Confirm alignment and layout of the fence panels per the project plans.

## 3.2 Removal of Existing Posts and Grout

- Carefully remove old fence posts to avoid damaging the CMU wall.
- Completely remove old grout from post pockets, ensuring openings are clean and free of debris.

## 3.3 Installation of New Fence Posts

- **Post Alignment:** Position new fence posts in the CMU wall pockets according to the specified layout, maintaining consistent spacing and alignment.
- **Post Preparation:** Clean and prepare the post ends for optimal grout adhesion.

- **Grouting:**
  - Fill CMU wall post pockets with non-shrink, high-strength grout.
  - Use tools to eliminate air pockets and ensure full grout coverage around each post.
  - Verify post alignment and plumbness during grout curing.
- **Curing:** Allow grout to cure according to manufacturer recommendations before proceeding with fence panel installation.

### 3.4 Installation of Fence Panels

- **Panel Attachment:** Securely fasten fence panels to posts using manufacturer-supplied brackets and fasteners. Ensure proper alignment and uniform height.
- **Racking:** Adjust panels as needed to follow the grade or slope of the wall, utilizing the rackable design of the system.
- **Hardware:** Tighten all fasteners to prevent movement but avoid over-tightening, which could damage the coating or components.

### 3.5 Adjustments and Cleaning

- Confirm that all posts and panels are securely installed, aligned, and properly spaced.
- Clean the CMU wall, posts, and panels to remove any grout, dust, or debris from the installation process.
- Repair any damage to the protective coating of the fence system with manufacturer-approved touch-up materials.

### 3.6 Protection

- Protect the newly installed fence system from damage during the remainder of the construction project.
- Install temporary barriers or signage to prevent accidental contact with the fence.

**Wrought Iron Fencing on the tennis court side of Via Zamora atop the upper retaining wall. - Replacement**



**8. ORAL COMMUNICATION - INFORMATIONAL ITEMS, which do not require action but relate to District business, will be reported by members of the Board and staff as follows:**

- A. Chair Dransfeldt
- B. Ventura County/California Special District Association
- C. Santa Monica Mountains Conservancy
- D. Standing Committees: Long Range Planning, Policy and Finance
- E. Foundation for Pleasant Valley Recreation and Parks
- F. General Manager's Report
- G. Board Members